



Service Manual

The essentials of imaging

magicolor 7300

Contents

1. SAFETY PRECAUTIONS FOR INSPECTION AND SERVICE	P-1
1-1. Warning	P-1
1-2. Caution	P-3
1-3. Used Batteries Precautions	P-5
1-4. Other Precautions	P-6
1-5. Precautions for Service	P-6
1-6. Safety information	P-10
(1) Laser Safety	P-10
(2) Internal Laser Radiation	P-10
1-7. Laser Safety Label	P-13
1-8. Laser Caution Label	P-13
1-9. Precautions for Handling the Laser Equipment	P-13
GENERAL	
1. SPECIFICATIONS	G-1
2. PRECAUTIONS FOR INSTALLATION	G-4
2-1. Installation Site	G-4
2-2. Power Source	G-4
2-3. Grounding	G-4
2-4. Space Requirements	G-5
3. PRECAUTIONS FOR USE	G-6
3-1. To ensure that the printer is used in an optimum condition	G-6
3-2. Operating Environment	G-6
3-3. Power Requirements	G-6
3-4. Other Precautions	G-6
4. HANDLING CONSUMABLES	G-7
5. LIST OF NAMES	G-8
MECHANICAL/ELECTRICAL	
1. CROSS-SECTION VIEW	M-1
2. ELECTRICAL PARTS LAYOUT	M-2
2-1. Printer	M-2
2-2. Controller	M-4
3. OPERATING SEQUENCE	M-5
4. IMAGE STABILIZATION CONTROL	M-6
4-1. Image Stabilization Control	M-6
4-2. Operation Timing	M-7
4-3. Image stabilization control flow	M-8
4-4. AIDC Sensor	M-9

5.	PRINT HEAD (PH)	M-10
5-1.	System Configuration	M-10
5-2.	Laser exposure process	M-11
5-3.	Laser emission timing	M-12
5-4.	Laser emission area	M-13
	(1) FD Direction	M-13
	(2) CD Direction	M-13
5-5.	Cooling of Print Head Unit	M-14
6.	PRINT UNIT	M-15
6-1.	System Configuration	M-15
6-2.	Drive Print Unit	M-16
	(1) Drive Overall Unit	M-16
	(2) Drive in Unit	M-16
6-3.	Print Unit Detection	M-17
	(1) Set detection	M-17
	(2) New unit detection	M-17
6-4.	Toner Cartridge detection	M-17
	(1) Set detection	M-17
	(2) New unit detection	M-17
6-5.	PC Drum	M-18
6-6.	PC Drum Charging	M-19
	(1) Charged area Ozone Ventilation	M-20
6-7.	Developing Section	M-21
	(1) Composition	M-21
	(2) Toner Conveyor	M-22
	(3) Developing System	M-23
	(4) Toner Level Detection	M-24
	(5) Toner Cartridge Shutter Open/Close Mechanism	M-25
6-8.	Cleaner	M-26
7.	IMAGE TRANSFER SECTION	M-27
7-1.	Construction of Transfer Belt Unit	M-27
7-2.	Transfer Belt Unit Drive	M-28
7-3.	New Transfer Belt Unit Detection	M-28
7-4.	Transfer Belt Unit Set Detection	M-29
7-5.	Color Shift Detection	M-30
	(1) Simple correction	M-30
	(2) Full correction	M-30
7-6.	Color Shift Correction	M-31
7-7.	First Image Transfer Roller Pressure/ Retraction Mechanism	M-33
	(1) Pressure/Retraction Mechanism	M-33
	(2) Pressure Position Switching Mechanism	M-34
7-8.	2nd Image Transfer Pressure/Retraction Mechanism	M-35
7-9.	2nd Image Transfer	M-36
7-10.	2nd Image Transfer	M-36
7-11.	Image Transfer ATVC Control	M-37

7-12.	Temperature/Humidity Sensor	M-38
7-13.	Transfer Belt Cleaning Mechanism	M-39
7-14.	Cleaning the 2nd Image Transfer Roller	M-39
7-15.	Waste Toner Box	M-40
	(1) Installing the Waste Toner Box	M-40
	(2) Waste Toner Near-Full/Full Detection	M-40
8.	FUSING SECTION	M-41
8-1.	Drive of Fuser Unit	M-41
8-2.	Fuser Unit Drive	M-42
8-3.	Control of Loop Before Fusing	M-42
8-4.	New Fuser Unit Detection	M-43
8-5.	Pressure of Fusing Roller	M-43
8-6.	Temperature Control	M-44
	(1) Fusing Temperature control flow	M-44
	(2) Control at Warm-up	M-45
	(3) Temperature Control During Standby	M-45
	(4) Temperature Control During Printing	M-46
	(5) Pre-heat Mode Control	M-46
	(6) Sleep Mode	M-46
	(7) Heating heater switch control	M-47
9.	PAPER TAKE-UP SECTION	M-48
9-1.	1st Drawer	M-48
	(1) Tray set detection	M-48
	(2) Paper Size Detection	M-49
	(3) Paper Near-empty Detection	M-50
	(4) Paper Empty Detection	M-50
	(5) Paper Take-Up Mechanism	M-51
9-2.	2nd Drawer	M-52
	(1) Tray set detection	M-52
	(2) Paper Size Detection	M-53
	(3) Paper Empty Detection	M-54
	(4) Paper Empty Detection	M-54
	(5) Paper Take-Up Mechanism	M-55
	(6) Vertical Transport Mechanism	M-55
	(7) Edge Guides and Trailing Edge Stop	M-56
	(8) Paper Lifting Plate	M-56
9-3.	Manual Bypass Paper Take-Up Unit (Optional)	M-57
	(1) Manual Feed Paper Take-Up Mechanism	M-57
	(2) Manual feed operation	M-57
10.	TRANSPORT SECTION	M-58
10-1.	Synchronizing Roller Drive	M-58
10-2.	Image Transfer Failure Prevention During High Humidity	M-58
10-3.	Switch of system speed	M-59
10-4.	OHP Detecting	M-59

11. DUPLEX UNIT (OPTIONAL)	M-60
11-1. Drive of Duplex Unit	M-60
11-2. Paper Feeding System	M-61
(1) Operations in 2-sided printing with a single sheet of paper resident in, and circulated through, the system	M-61
(2) Operations for 2-sided printing with two sheets of paper resident in the system, and with a new sheet of paper taken up when a printed page with images printed on both sides is fed out.	M-62

MAINTENANCE

1. MAINTENANCE SCHEDULE LIST	E-1
1-1. Guidelines for Life-time Expected Values by Unit	E-3
(1) Guideline for Near-Life values	E-3
(2) Guidelines for life value	E-3
2. DISASSEMBLY/REASSEMBLY AND CLEANING	E-5
(1) Cleaning the Paper Take-Up Roll	E-5
(2) Replacing the Paper Take-Up Roll	E-5
(3) Cleaning the Paper Separator Roll	E-6
(4) Replacing of the Separator Roll Assembly	E-7
(5) Cleaning the Vertical Transport Roller/Roll	E-7
(6) Replacing the Waste Toner Box	E-8
(7) Replacing the Ozone Filter	E-9
3. REPLACING THE UNITS	E-10
(1) Replacing the Print Unit	E-10
(2) Replacing the Toner Cartridge	E-16
(3) Replacing the Fuser Unit	E-19
(4) Replacing the Transfer Belt Unit	E-22

ASSEMBLY/DISASSEMBLY

1. SERVICE INSTRUCTIONS	D-1
1-1. Identification of Fuses	D-1
1-2. Parts Which Must Not Be Touched	D-2
(1) Screws that must not be removed	D-2
(2) Do not turn on the Variable Resistors on Board	D-2
2. ASSEMBLY/DISASSEMBLY	D-3
2-1. Doors, Covers and Exterior Parts	D-3
2-2. Removing Doors, Covers and Exterior Parts	D-4
(1) Removing the Front Door	D-4
(2) Removing the Left Cover	D-5
(3) Removing the Panel Cover	D-5
(4) Removing the Top Cover	D-6
(5) Remove the Ozone Filter Cover	D-6
(6) Removing the Rear Cover	D-6
2-3. Removing Circuit Boards and other Electrical Components	D-7

	<Engine>	
	(1) Removing the Control Board	D-8
	<Removal Procedures>	
	<Reinstallation procedures>	
	(2) Removing the Controller Board	D-12
	(3) Remove the 2nd Drawer Control Board	D-13
	(4) Removing the High Resistance Board	D-14
	(5) Removing the First Drawer Paper Size Detecting Board	D-14
	(6) Removing the Heater Lamp Control Board	D-15
	(7) Removing the DC Power Supply	D-16
	(8) Removing the Control Panel	D-17
	(9) Removing High Voltage Units 1 and 2	D-17
	<Manual Feed Unit (optional)>	
	(1) Removing the Manual Feed Detecting Board	D-18
	<Duplex Unit (optional)>	
	(1) Removing the Duplex Unit Control Board	D-19
	<Paper Feed Unit (optional)>	
	(1) Removing the Paper Feed Unit Control Board	D-20
2-4.	Removing Units	D-22
	(1) Removing the Print Head Unit	D-22
	(2) Removing the 2nd Drawer	D-23
	(3) Removing of the Manual Feed Unit (optional)	D-25
	(4) Removing the Duplex Unit (optional)	D-26
	(5) Removing of the Paper Feed Unit (optional)	D-28
2-5.	Cleaning and Disassembly of the Engine Parts	D-31
	(1) Composition of Transfer Belt Unit	D-31
	(2) Cleaning of the Fusing Entrance Guide Plate	D-31
	(3) Cleaning the Print Head Unit window surface	D-32
	(4) Cleaning the AIDC Sensor	D-32
	(5) Removing the Paper Supply Drive Motor	D-32
	(6) Removing the Transport Drive Motor	D-33
	(7) Removing the Transport Roller Motor	D-33
	(8) Removing the Print Unit Drive Motor YMC/Bk	D-34
	(9) Removing the 1st Image Transfer Pressure/Retraction Clutch	D-34
	(10) Remove the 2nd Drawer Paper Take-Up Clutch	D-35
	(11) Remove the Paper Take-Up Motor for the 2nd Drawer ...	D-36
	(12) Removing the Registration Sensor	D-37
	(13) Removing the Temperature/Humidity Sensor	D-38
	(14) Removing the Hard Disk Drive (optional)	D-39
2-6.	Disassembling the Manual Feed Unit (optional)	D-40
	(1) Removing the Manual Feed Motor	D-40
	(2) Removing the Paper Take-Up Drive Roller	D-41
2-7.	Disassembling the Duplex Unit (optional)	D-43
	(1) Removing the Duplex Unit Drive Motor	D-43

(2) Removing the Wire Stopper	D-44
<Reinstallation Procedure>	
2-8. Disassembling the Paper Feed Unit (optional)	D-48
(1) Removing the Paper Take-Up Clutch	D-48
(2) Removing the Paper Take-Up Motor	D-49

CONTROL PANEL/Panel Menu Operations

1. CONTROL PANEL	S-1
1-1. Names and Functions of Control Panel Keys	S-1
1-2. Control Panel Display	S-3
(1) Basic Screen	S-3
(2) Warning Screen	S-3
1-3. Control Panel Message	S-4
(1) Standard State Message	S-4
(2) Caution Message	S-4
(3) Start-up Messages	S-5
(4) Operator Call Message	S-6
(5) Service Call Message	S-7
1-4. Canceling a Print Job	S-8
2. PANEL MENU	S-9
2-1. Summary of Panel Menu	S-9
2-2. Sub-menu	S-10
(1) PAPER	S-10
(2) QUALITY	S-11
(3) INTERFACE	S-12
(4) SYS DEFAULT	S-13
(5) SERVICE	S-14
2-3. Contents of Panel Menu	S-15
(1) PRINT	S-15
(2) PAPER	S-15
(3) QUALITY	S-16
(4) INTERFACE	S-16
(5) SYS DEFAULT	S-17
(6) SERVICE	S-18
(7) PASSWORD PROTECTION	S-19
3. MAINTENANCE MODE	S-20
3-1. SETTING THE MAINTENANCE MODE	S-20
3-2. Summary of the Maintenance Mode	S-21
3-3. Maintenance Menu	S-21
3-4. Contents of Maintenance Mode	S-22
(1) REGIST ROLLER	S-22
(2) TRANSFER POWER	S-22
(3) RESTORE PASSWORD	S-22
4. UPDATE FIRMWARE	S-23
4-1. Update using IEEE1284 Parallel Cable	S-23

4-2.	Network Cable (FTP) Update	S-25
4-3.	When Update Fails	S-26

TROUBLESHOOTING

1.	INTRODUCTION	T-1
1-1.	Checking the electrical components	T-1
	(1) Sensor	T-1
	(2) Switch	T-2
	(3) Solenoid	T-2
	(4) Clutch	T-3
	(5) Motor	T-3
1-2.	System Control Block Diagram	T-5
2.	JAM	T-6
2-1.	Initial Check Items	T-6
2-2.	Misfeed Display	T-7
2-3.	Misfeed Detecting Sensor Layout	T-8
2-4.	Misfeed Detection Timing/Troubleshooting Procedures	T-9
	(1) Misfeed in the 1st Drawer Paper Take-Up Section	T-9
	(2) 2nd Drawer Paper Misfeed	T-10
	(3) 3rd and 4th Drawers Paper Take-Up Section Misfeed (Optional)	T-11
	(4) Manual Bypass Take-Up Misfeed (Optional)	T-12
	(5) Duplex Paper Take-up Section Misfeed (Optional)	T-13
	(6) Duplex Transport Section Misfeed (Optional)	T-14
	(7) Vertical Transport Misfeed	T-15
	(8) 2nd Image Transfer Misfeed	T-17
	(9) Fusing/Exit Misfeed	T-18
3.	MALFUNCTIONS	T-19
3-1.	Malfunction Codes	T-19
3-2.	Malfunction Detection Timing and Troubleshooting Procedure	T-21
	(1) C15, C23, C24: Boot Flash ROM Access Failure	T-21
	(2) C26, C27: SMARTMEDIA Write/Read Failure	T-21
	(3) C50: HDD Access Failure	T-22
	(4) C28: LSI Calibration Failure	T-22
	(5) C02, C03: RAM Access Failure	T-23
	(6) C22: EEPROM Access Failure	T-23
	(7) C13: MAC Address Error	T-24
	(8) C51: HDD Data Capacity Full	T-24
	(9) 13C8: New Transfer Belt Unit resetting failure	T-25
	(10) 13CA: New Fuser Unit resetting failure	T-25
	(11) 13D0: EEPROM Failure (Main Unit)	T-26
	(12) 13D5: EEPROM Failure (PH Unit)	T-26
	(13) 13E2: Flash ROM Write Failure	T-27
	(14) 13E3: Flash ROM Device Failure	T-27
	(15) 0010: PU Drive Motor C/M/Y Failure	T-28

(16)0017: PU Drive Motor Bk Failure	T-28
(17)3046: Fusing Cooling Fan Motor Failure	T-29
(18)3047: PH Cooling Fan Motor Failure	T-29
(19)3048: PU Cooling Fan Motor Failure	T-29
(20)0040: Suction Fan Motor Failure	T-29
(21)004C: Ozone Fan Motor Failure	T-29
(22)004E: Power Supply Cooling Fan Motor Failure	T-29
(23)0094: 2nd Image Transfer Roller Pressure/Retraction failure	T-32
(24)0096: Image Transfer Belt Pressure/Retraction failure	T-32
(25)0060: Fusing Drive Motor Failure	T-33
(26)3020: Paper Take-Up Drive Motor Failure	T-33
(27)3021: Transport Drive Motor Failure	T-33
(28)3022: Duplex Unit Drive Motor Failure	T-33
(29)3023: Manual Bypass Unit Paper Take-Up Motor Failure	T-33
(30)0250: Power Supply (24 V) Failure	T-35
(31)0300: Polygon Motor Failure	T-36
(32)0310: Laser Failure	T-36
(33)0500: Heating Roller Warm-Up Failure	T-37
(34)0501: Fusing Pressure Warm-Up Failure	T-37
(35)0510: Heating Roller abnormally low temperature	T-37
(36)0511: Fusing Pressure Roller abnormally low temperature	T-37
(37)0520: Heating Roller abnormally high temperature	T-37
(38)0521: Fusing Pressure Roller abnormally high temperature	T-37
(39)FFFF: I/F Communication Failure	T-38
4. POWER SUPPLY-RELATED MALFUNCTIONS	T-39
4-1. Printer is not energized at all	T-39
5. OTHER PRECAUTIONS	T-40
5-1. Emergency Stop Error	T-40
(1) Door Open Error	T-40
(2) Unit not mounted error	T-40
5-2. Print Prohibition Error	T-41
5-3. Warning Error	T-41
6. IMAGE PROBLEM	T-42
6-1. Troubleshooting Procedure by a Particular Image Quality Problem	T-42
(1) IR System: white lines in FD, white bands in FD, colored lines in FD, and colored bands in FD	T-42
(2) white lines in CD, white bands in CD, colored lines in CD, and colored bands in CD	T-44
(3) Uneven FD Density	T-45
(4) Uneven CD Density	T-46
(5) Low Density (lowered ID)	T-47

(6) Gradation Failure	T-48
(7) Color Reproduction Failure	T-49
(8) Foggy Background	T-50
(9) Void area, white spots	T-51
(10) Faulty Image	T-52
(11) Blank Copy, Black Copy	T-53
(12) Color Shift Failure	T-54
(13) Colored Spots	T-55
(14) Poor Fusing Performance, Offset	T-56
(15) Brush Effect, Blurred Image	T-57
(16) Back Marking	T-58
(17) Uneven Pitch	T-59

1. SAFETY PRECAUTIONS FOR INSPECTION AND SERVICE

- When performing inspection and service procedures, observe the following precautions to prevent accidents and ensure utmost safety.
- * Depending on the model, some of the precautions given in the following do not apply.
- Different markings are used to denote specific meanings as detailed below.



- Indicates a potentially hazardous situation which, if not avoided, could result in death or serious injury.



- Indicates a potentially hazardous situation which, if not avoided, may result in minor or moderate injury. It may also be used to alert against unsafe practices.
- The following graphic symbols are used to give instructions that need to be observed.



Used to call the service technician attention to what is graphically represented inside the marking (including a warning).



Used to prohibit the service technician from doing what is graphically represented inside the marking.



Used to instruct the service technician to do what is graphically represented inside the marking.

1-1. Warning



1. Always observe precautions.



- Parts requiring special attention in this product will include a label containing the mark shown on the left plus precautionary notes. Be sure to observe the precautions.
- Be sure to observe the "Safety Information" given in the Operator's Manual.

WARNING

2. Before starting the procedures, be sure to unplug the power cord.



- This product contains a high-voltage unit and a circuit with a large current capacity that may cause an electric shock or burn.
- The product also contains parts that can jerk suddenly and cause injury.
- If this product uses a laser, laser beam leakage may cause eye damage or blindness.

3. Do not throw toner or the toner bottle into a fire.



- Do not throw toner or the Toner Bottle (Imaging Cartridge, Toner Cartridge) into a fire. Toner expelled from the fire may cause burns.

4. Use the specified parts.



- For replacement parts, always use the genuine parts specified in the manufacturer's parts manual. Installing a wrong or unauthorized part could cause dielectric breakdown, overload, or undermine safety devices resulting in possible electric shock or fire.
- Replace a blown electrical fuse or thermal fuse with its corresponding genuine part specified in the manufacturer's parts manual. Installing a fuse of a different make or rating could lead to a possible fire. If a thermal fuse blows frequently, the temperature control system may have a problem and action must be taken to eliminate the cause of the problem.

5. Handle the power cord with care and never use a multiple outlet.



- Do not break, crush or otherwise damage the power cord. Placing a heavy object on the power cord, or pulling or bending it may damage it, resulting in a possible fire or electric shock.
- Do not use a multiple outlet to which any other appliance or machine is connected.
- Be sure the power outlet meets or exceeds the specified capacity.
- Use only the power cord supplied in the package. If a power cord is not supplied, only use the power cord and plug that is specified in POWER CORD INSTRUCTION. Failure to use this cord could result in a fire or electrical shock.
- Use the power cord supplied in the package only for this machine and NEVER use it for any other product. Failure to observe this precaution could result in a fire or electrical shock.

6. Be careful with the high-voltage parts.



- A part marked with the symbol shown on the left carries a high voltage. Touching it could result in an electric shock or burn. Be sure to unplug the power cord before servicing this part or the parts near it.

7. Do not work with wet hands.



- Do not unplug or plug in the power cord, or perform any kind of service or inspection with wet hands. Doing so could result in an electric shock.



WARNING

8. Do not touch a high-temperature part.



- A part marked with the symbol shown on the left and other parts such as the exposure lamp and fusing roller can be very hot while the machine is energized. Touching them may result in a burn.
- Wait until these parts have cooled down before replacing them or any surrounding parts.

9. Maintain a grounded connection at all times.



- Connect the power cord to an electrical outlet that is equipped with a grounding terminal.

10. Do not remodel the product.



- Modifying this product in a manner not authorized by the manufacturer may result in a fire or electric shock. If this product uses a laser, laser beam leakage may cause eye damage or blindness.

11. Restore all parts and harnesses to their original positions.



- To promote safety and prevent product damage, make sure the harnesses are returned to their original positions and properly secured in their clamps and saddles in order to avoid hot parts, high-voltage parts, sharp edges, or being crushed.
- To promote safety, make sure that all tubing and other insulating materials are returned to their original positions. Make sure that floating components mounted on the circuit boards are at their correct distance and position off the boards.

1-2. Caution



CAUTION

1. Precautions for Service Jobs.



- A star washer and spring washer, if used originally, must be reinstalled. Omitting them may result in contact failure which could cause an electric shock or fire.
- When reassembling parts, make sure that the correct screws (size, type) are used in the correct places. Using the wrong screw could lead to stripped threads, poorly secured parts, poor insulating or grounding, and result in a malfunction, electric shock or injury.
- Take great care to avoid personal injury from possible burrs and sharp edges on the parts, frames and chassis of the product.
- When moving the product or removing an option, use care not to injure your back or allow your hands to be caught in mechanisms.

CAUTION

2. Precautions for Servicing with Covers and Parts Removed.



- Wherever feasible, keep all parts and covers mounted when energizing the product.
- If energizing the product with a cover removed is absolutely unavoidable, do not touch any exposed live parts and use care not to allow your clothing to be caught in the moving parts. Never leave a product in this condition unattended.
- Never place disassembled parts or a container of liquid on the product. Parts falling into, or the liquid spilling inside, the mechanism could result in an electric shock or fire.



- Never use a flammable spray near the product. This could result in a fire.
- Make sure the power cord is unplugged before removing or installing circuit boards or plugging in or unplugging connectors.
- Always use the interlock switch actuating jig to actuate an interlock switch when a cover is opened or removed. The use of folded paper or some other object may damage the interlock switch mechanism, possibly resulting in an electric shock, injury or blindness.

3. Precautions for the Working Environment.



- The product must be placed on a flat, level surface that is stable and secure.
- Never place this product or its parts on an unsteady or tilting workbench when servicing.
- Provide good ventilation at regular intervals if a service job must be done in a confined space for a long period of time.
- Avoid dusty locations and places exposed to oil or steam.
- Avoid working positions that may block the ventilation ports of the product.

4. Precautions for Handling Batteries. (Lithium, Nickel-Cadmium, etc.)



- Replace a rundown battery with the same type as specified in the manufacturer's parts manual.
- Before installing a new battery, make sure of the correct polarity of the installation or the battery could burst.
- Dispose of used batteries according to the local regulations. Never dispose of them at the user's premises or attempt to try to discharge one.

5. Precautions for the Laser Beam. (Only for Products Employing a Laser)



- Removing the cover marked with the caution label could lead to possible exposure to the laser beam, resulting in eye damage or blindness. Be sure to unplug the power cord before removing this cover.
- If removing this cover while the power is ON is unavoidable, be sure to wear protective laser goggles that meet specifications.
- Make sure that no one enters the room when the machine is in this condition.
- When handling the laser unit, observe the "Precautions for Handling Laser Equipment."

6. Precautions for storing the toner or imaging cartridge.



- Be sure to keep the toner or imaging cartridge out of the reach of children. Licking the imaging cartridge or ingesting its contents is harmful to your health.

1-3. Used Batteries Precautions

ALL Areas

CAUTION

Danger of explosion if battery is incorrectly replaced.

Replace only with the same or equivalent type recommended by the manufacturer.

Dispose of used batteries according to the manufacturer's instructions.

Germany

VORSICHT!

Explosionsgefahr bei unsachgemäßem Austausch der Batterie.

Ersatz nur durch denselben oder einen vom Hersteller empfohlenen gleichwertigen Typ.

Entsorgung gebrauchter Batterien nach Angaben des Herstellers.

France

ATTENTION

Il y a danger d'explosion s'il y a remplacement incorrect de la batterie.

Remplacer uniquement avec une batterie du même type ou d'un type équivalent recommandé par le constructeur.

Mettre au rebut les batteries usagées conformément aux instructions du fabricant.

Denmark

ADVARSEL!

Lithiumbatteri - Eksplosionsfare ved fejlagtig håndtering.

Udskiftning må kun ske med batteri af samme fabrikat og type.

Levér det brugte batteri tilbage til leverandøren.

Finland, Sweden

VAROITUS

Paristo voi räjähtää, jos se on virheellisesti asennettu.

Vaihda paristo ainoastaan laitevalmistajan suosittelemaan tyyppiin.

Hävittä käytetty paristo valmistajan ohjeiden mukaisesti.

VARNING

Explosionsfara vid felaktigt batteribyte.

Använd samma batterityp eller en ekvivalent typ som rekommenderas av apparattillverkaren.

Kassera använt batteri enligt fabrikantens instruktion.

Norway

ADVARSEL

Eksplosjonsfare ved feilaktig skifte av batteri.

Benytt samme batteritype eller en tilsvarende type anbefalt av apparatfabrikanten.

Brukte batterier kasseres i henhold til fabrikantens instruksjoner.

1-4. Other Precautions

- When handling circuit boards, observe the "HANDLING of PWBs".
- The PC Drum is a very delicate component. Observe the precautions given in "HANDLING OF THE PC DRUM" because mishandling may result in serious image problems.
- Note that replacement of a circuit board may call for readjustments or resetting of particular items, or software installation.

1-5. Precautions for Service

- When performing inspection and service procedures, observe the following precautions to prevent mishandling of the machine and its parts.
- * Depending on the model, some of the precautions given in the following do not apply.

1. Precautions Before Service

- When the user is using a word processor or personal computer from a wall outlet of the same line, take necessary steps to prevent the circuit breaker from opening due to overloads.
- Never disturb the LAN by breaking or making a network connection, altering termination, installing or removing networking hardware or software, or shutting down networked devices without the knowledge and express permission of the network administrator or the shop supervisor.

2. How to Use this Book

DIS/REASSEMBLY, ADJUSTMENT

- To reassemble the product, reverse the order of disassembly unless otherwise specified.

TROUBLESHOOTING

- If a component on a PWB or any other functional unit including a motor is defective, the text only instructs you to replace the whole PWB or functional unit and does not give troubleshooting procedures applicable within the defective unit.
- All troubleshooting procedures contained herein assume that there are no breaks in the harnesses and cords and all connectors are plugged into the right positions.
- The procedures preclude possible malfunctions due to noise and other external causes.

3. Precautions for Service

- Keep all disassembled parts in good order and keep tools under control so that none will be lost or damaged.
- After completing a service job, perform a safety check. Make sure that all parts, wiring and screws are returned to their original positions.
- Do not pull out the toner hopper while the toner bottle is turning. This could result in a damaged motor or locking mechanism.
- If the product is to be run with the front door open, make sure that the toner hopper is in the locked position.
- Do not use an air gun or vacuum cleaner for cleaning the ATDC Sensor and other sensors, as they can cause electrostatic destruction. Use a blower brush and cloth. If a unit containing these sensors is to be cleaned, first remove the sensors from the unit.

4. Precautions for Dis/Reassembly

- Be sure to unplug the printer from the outlet before attempting to service the printer.
- The basic rule is not to operate the printer anytime during disassembly. If it is absolutely necessary to run the printer with its covers removed, use care not to allow your clothing to be caught in revolving parts such as the timing belt and gears.
- Before attempting to replace parts and unplug connectors, make sure that the power cord of the printer has been unplugged from the wall outlet.
- Be sure to use the Interlock Switch Actuating Jig whenever it is necessary to actuate the Interlock Switch with the covers left open or removed.
- While the product is energized, do not unplug or plug connectors into the circuit boards or harnesses.
- Never use flammable sprays near the printer.
- A used battery should be disposed of according to the local regulations and never be discarded casually or left unattended at the user's premises.
- When reassembling parts, make sure that the correct screws (size, type) and toothed washer are used in the correct places.

5. Precautions for Circuit Inspection

- Never create a closed circuit across connector pins except those specified in the text and on the printed circuit.
- When creating a closed circuit and measuring a voltage across connector pins specified in the text, be sure to use the GND wire.

6. Handling of PWBs

During Transportation/Storage

- During transportation or when in storage, new P.W. Boards must not be indiscriminately removed from their protective conductive bags.
- Do not store or place P.W. Boards in a location exposed to direct sunlight and high temperature.
- When it becomes absolutely necessary to remove a Board from its conductive bag or case, always place it on its conductive mat in an area as free as possible from static electricity.
- Do not touch the pins of the ICs with your bare hands.
- Protect the PWBs from any external force so that they are not bent or damaged.

During Inspection/Replacement

- Avoid checking the IC directly with a multimeter; use connectors on the Board.
- Never create a closed circuit across IC pins with a metal tool.
- Before unplugging connectors from the P.W. Boards, make sure that the power cord has been unplugged from the outlet.
- When removing a Board from its conductive bag or conductive case, do not touch the pins of the ICs or the printed pattern. Place it in position by holding only the edges of the Board.
- When touching the PWB, wear a wrist strap and connect its cord to a securely grounded place whenever possible. If you cannot wear a wrist strap, touch a metal part to discharge static electricity before touching the PWB.
- Note that replacement of a PWB may call for readjustments or resetting of particular items.

7. Handling of Other Parts

- The magnet roller generates a strong magnetic field. Do not bring it near a watch, floppy disk, magnetic card, or CRT tube.

8. Handling of the PC Drum

* Only for Products Not Employing an Imaging Cartridge.

During Transportation/Storage

- Use the specified carton whenever moving or storing the PC Drum.
- The storage temperature is in the range between -20°C and $+40^{\circ}\text{C}$.
- In summer, avoid leaving the PC Drum in a car for a long time.

Handling

- Ensure that the correct PC Drum is used.
- Whenever the PC Drum has been removed from the printer, store it in its carton or protect it with a Drum Cloth.
- The PC Drum exhibits greatest light fatigue after being exposed to strong light over an extended period of time. Never, therefore, expose it to direct sunlight.
- Use care not to contaminate the surface of the PC Drum with oil-base solvent, fingerprints, and other foreign matter.
- Do not scratch the surface of the PC Drum.
- Do not apply chemicals to the surface of the PC Drum.
- Do not attempt to wipe clean the surface of the PC Drum.

If, however, the surface is contaminated with fingerprints, clean it using the following procedure.

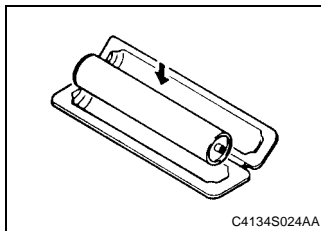

A. Place the PC Drum into one half of its carton.

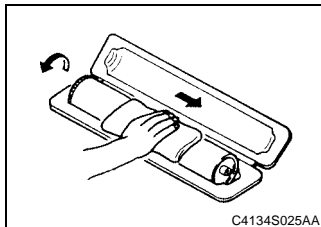

B. Gently wipe the residual toner off the surface of the PC Drum with a dry, Dust-Free Cotton Pad.

- Turn the PC Drum so that the area of its surface on which the line of toner left by the Cleaning Blade is present is facing straight up. Wipe the surface in one continuous movement from the rear edge of the PC Drum to the front edge and off the surface of the PC Drum.
- Turn the PC Drum slightly and wipe the newly exposed surface area with a CLEAN face of the Dust-Free Cotton Pad. Repeat this procedure until the entire surface of the PC Drum has been thoroughly cleaned.

* At this time, always use a CLEAN face of the dry Dust-Free Cotton Pad until no toner is evident on the face of the Pad after wiping.

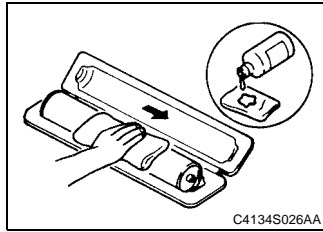

- C. Soak a small amount of either ethyl alcohol or isopropyl alcohol into a clean, unused Dust-Free Cotton Pad which has been folded over into quarters. Now, wipe the surface of the PC Drum in one continuous movement from its rear edge to its front edge and off its surface one to two times.
- * Never move the Pad back and forth.

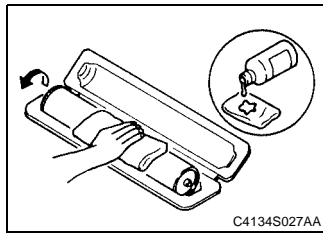

- D. Using the SAME face of the Pad, repeat the procedure explained in the latter half of step 3 until the entire surface of the PC Drum has been wiped. Always OVERLAP the areas when wiping. Two complete turns of the PC Drum would be appropriate for cleaning.

NOTES

- Even when the PC Drum is only locally dirtied, wipe the entire surface.
 - Do not expose the PC Drum to direct sunlight. Clean it as quickly as possible even under interior illumination.
 - If dirt remains after cleaning, repeat the entire procedure from the beginning one more time.
-

9. Handling of the Imaging Cartridge and Print Unit

* Only for Products Employing an Imaging Cartridge and Print Unit.

During Transportation/Storage

- The storage temperature is in the range between -20°C and $+40^{\circ}\text{C}$.
- In summer, avoid leaving the Imaging Cartridge and Print Unit in a car for a long time.

Handling

- Store the Imaging Cartridge and Print Unit in a place that is not exposed to direct sunlight.

Precautionary Information on the PC Drum Inside the Imaging Cartridge and Print Unit

- Use care not to contaminate the surface of the PC Drum with oil-base solvent, fingerprints, and other foreign matter.
- Do not scratch the surface of the PC Drum.
- Do not attempt to wipe clean the surface of the PC Drum.

1-6. Safety information

(1) Laser Safety

- This is a digital machine certified as a class 1 laser product. There is no possibility of danger from a laser, provided the machine is serviced according to the instruction in this manual.

(2) Internal Laser Radiation

semiconductor laser	
Maximum power of the laser diode	15 mW
Maximum average radiation power(*)	7.351 μ W
Wavelength	770-800 nm

*:at laser aperture of the Print Head Unit

- This product employs a Class 3b laser diode that emits an invisible laser beam. The laser diode and the scanning polygon mirror are incorporated in the print head unit.
- The print head unit is NOT A FIELD SERVICE ITEM. Therefore, the print head unit should not be opened under any circumstances.

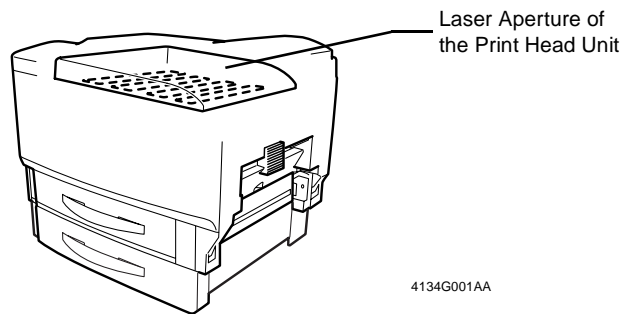

This figure shows the view inside the Top Cover with the Toner Cartridge and the Drum Cartridge removed.

**the U.S.A., Canada
(CDRH Regulation)**

- This machine is certified as a Class I Laser product under Radiation Performance Standard according to the Food, Drug and Cosmetic Act of 1990. Compliance is mandatory for Laser products marketed in the United States and is reported to the Center for Devices and Radiological Health (CDRH) of the U.S. Food and Drug Administration of the U.S. Department of Health and Human Services (DHHS). This means that the device does not produce hazardous laser radiation.
- The label shown to page 13 indicates compliance with the CDRH regulations and must be attached to laser products marketed in the United States.

CAUTION

Use of controls, adjustments or performance of procedures other than those specified in this manual may result in hazardous radiation exposure.

semiconductor laser	
Maximum power of the laser diode	15 mW
Wavelength	770-800 nm

All Areas

CAUTION

Use of controls, adjustments or performance of procedures other than those specified in this manual may result in hazardous radiation exposure.

semiconductor laser	
Maximum power of the laser diode	15 mW
Wavelength	770-800 nm

Denmark

ADVARSEL

Usynlig laserstråling ved åbning, når sikkerhedsafbrydere er ude af funktion.
Undgå udsættelse for stråling. Klasse 1 laser produkt der opfylder IEC60825 sikkerheds kravene.

halvlederlaser	
Laserdiodens højeste styrke	15 mW
bølgelængden	770-800 nm

Finland, Sweden

LUOKAN 1 LASERLAITE
KLASS 1 LASER APPARAT

VAROITUS!

Laitteen käyttäminen muulla kuin tässä käyttöohjeessa mainitulla tavalla saattaa altistaa käyttäjän turvallisuusluokan 1 ylittävälle näkymättömälle lasersäteilylle.

puolijohdelaser	
Laserdiodin suurin teho	15 mW
aallonpituus	770-800 nm

WARNING!

Om apparaten används på annat sätt än i denna bruksanvisning specificerats, kan användaren utsättas för osynlig laserstrålning, som överskrider gränsen för laserklass 1.

halvledarlaser	
Den maximala effekten för laserdioden	15 mW
våglängden	770-800 nm

VARO!

Avattaessa ja suojalukitus ohitettaessa olet alttiina näkymättömälle lasersäteilylle. Älä katso säteeseen.

WARNING!

Osynlig laserstrålning när denna del är öppen och spärren är urkopplad. Betrakta ej strålen.

Norway

ADVERSEL

Dersom apparatet brukes på annen måte enn spesifisert i denne bruksanvisning, kan brukeren utsettes for usynlig laserstrålning, som overskrider grensen for laser klass 1.

halvleder laser	
Maksimal effekt till laserdiode	15 mW
bølgelengde	770-800 nm

1-7. Laser Safety Label

- A laser safety label is attached to the the machine as shown below.

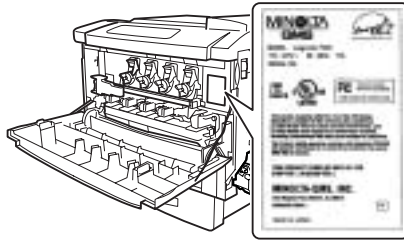

C4134o118AA

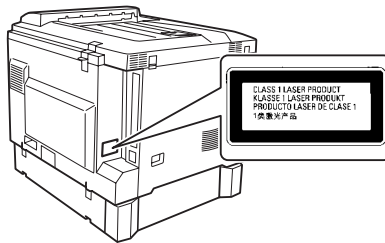

C4134o146AB

1-8. Laser Caution Label

- A laser caution label is attached to the inside of the machine as shown below.

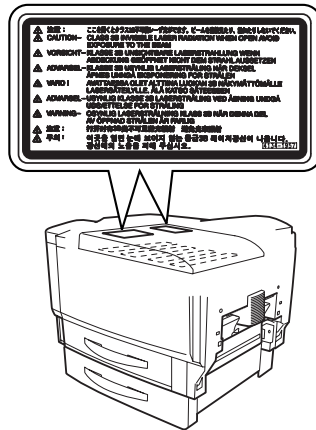

C4134o066AD

1-9. PRECAUTIONS FOR HANDLING THE LASER EQUIPMENT

- When laser protective goggles are to be used, select ones with a lens conforming to the above specifications.
- When a disassembly job needs to be performed in the laser beam path, such as when working around the printerhead and PC Drum, be sure first to turn the printer OFF.
- If the job requires that the printer be left ON, take off your watch and ring and wear laser protective goggles.
- A highly reflective tool can be dangerous if it is brought into the laser beam path. Use utmost care when handling tools on the user's premises.
- The Print Head are not to be disassembled or adjusted in the field. Replace the Unit or Assembly including the Control Board. Therefore, remove the Laser Diode, and do not perform Control Board trimmer adjustment.



GENERAL

1. SPECIFICATIONS

Printer

TYPE	: Desktop tandem color laser beam printer
Printing System	: Semiconductor laser and electrostatic image transfer to plain
Exposure System	: paper
Printing Density	: Laser diode and polygon mirror
Paper Size	: 600 × 600 dpi 1st Drawer: A5, ISO B5, JIS B5, A4, B4, A3, Oversized, Folio, SP Folio, Statement, Executive, Government Letter, Letter, Government Legal, Legal, 11 × 17, 8 × 10, Foolscap, 12 × 18, Com10, DL, Monarch, C5, C6, Chokey #3, Chokey #4, Chinese 8K, Chinese 16K, Chinese 32K, Japanese official postcards, Irregular size (90 × 148 mm - 311 × 457 mm) 2nd Drawer: JIS B5, A4, B4, A3, Letter, Legal, Ledger
Paper Type	: 1st Drawer: plain paper, recycled paper (64-90 g/m ²), OHP paper, envelopes, label sheets, thick paper (91-210 g/m ²), and japanese official postcards 2nd Drawer: plain paper, recycled paper (64-90 g/m ²)
Fast Print Time	: For monochrome printing: 13 sec. (for A4C, 1st Drawer) For full color printing: 16 sec. (for A4C, 1st Drawer)
Multi-page Print Speed	: 21.6 sheets/minute (for A4C, 1st Drawer) 20.5 sheets/minute (for Letter C, 1st Drawer)
Warm-Up Time	: Within 99.9 seconds (at a room temperature of 23°C and at the rated voltage)
System Speed	: 90.3 mm/sec
Paper Feeding System	: 2-way system (maximum 5-way) *1 250 sheets of plain paper, recycled paper, 10 envelopes, 50 sheets of thick paper, label sheets, OHP transparencies, japanese official postcards 2nd Drawer (500 sheets) Expandable to 5-way system by installing the optional 3rd and 4th Drawer paper cassettes
Paper Ejection Method	: Face-down (tray capacity: 250 sheets)
Charging System	: DC comb electrode Scorotron System
Developing System	: Single-element developing system
Image Transfer System	: Intermediate Image Transfer Belt System
PC Drum	: OPC
PC Drum Cleaning	: Blade system
Paper Separator System	: Curvature separation + charge-neutralizing system
Fusing System	: Heated roller fusing system (Oil is not used)
Dimensions	: 628 mm (W) × 594 mm (D) × 564 mm (H)
Weight	: 58.6 kg (with PU/TC)
Power Requirements	: 120 V, 60 Hz ± 3 Hz, 12 A 220-240 V, 50-60 Hz ± 3 Hz, 6.5 A
Max. Power Consumption	: 1,400 W
Operating Noise	: During standby: 40 dB (A) or less During printing: 50 dB (A) or less (1st Drawer), 53 dB (A) or less (2nd Drawer)

Environmental
Conditions : 10-32.5 °C
15-85%
Option : Paper Feed Unit, Duplex Unit Kit (with Manual Feed Unit)

Lower Feeder Unit (optional)

Name : Lower Feeder Unit
Paper Type : Plain paper (64-90 g/m²), recycled paper (64-90 g/m²),
Paper Size : JIS B5, A4, B4, A3, Letter, Legal, Ledger
Capacity : 500 sheets (64 g/m²)
Paper Feed Separator : Torque Limiter Method
Power Requirements : Supplied by main unit
Size : 575 mm (W) × 568 mm (D) × 127 mm (H)
Weight : 8.5 kg

Duplex Unit Kit (optional)

Name : Duplex Unit
Paper Type : Plain paper (64-90 g/m²), recycled paper (64-90 g/m²)
Paper Size : A5, JIS B5, A4, B4, A3, Folio, SP Folio, Statement,
Executive, Government Letter, Letter, Government Legal,
Legal, Ledger, 8 × 10, Foolscap, Irregular size (90 × 148 mm
- 297 × 432 mm)
Print speed (double-
sided printing) : 17.5 pages/minute (for A4C, 1st Drawer)
17.0 pages/minute (for Letter C, 1st Drawer)
Paper transfer baseline : Center baseline
Power Requirements : Supplied by main unit
Size : 65 mm (W) × 445 mm (D) × 311 mm (H)
Weight : 2.1 kg

Name : Manual Feed Unit
Paper Type : Plain paper (64-90 g/m²), recycled paper (64-90 g/m²), OHP
paper, envelopes, label sheets, thick paper (91-210 g/m²),
government-standard postcards
Paper Size : A5, JIS B5, A4, B4, A3, Folio, SP Folio, Statement,
Executive, Government Letter, Letter, Government Legal,
Legal, Ledger, 8 × 10, Foolscap, ISO B5, Com10, DL,
Monarch, C5, C6, Chokei #3, Chokei #4, Chinese 8K,
Chinese 16K, Chinese 32K, Japanese-standard postcards,
Irregular size (90 × 148 mm - 297 × 432 mm), Irregular size
(210 × 433 mm - 297 × 900 mm)
long paper (210 × 433 mm - 297 × 900 mm)
Capacity : One sheet plain paper or one sheet specialty paper
Power Requirements : Supplied by main unit
Size : 98 mm (W) × 410 mm (D) × 88 mm (H)
Weight : 1.5 kg

Controller

Control Panel	: Message Window (16 digits × 2 lines), Indicator × 5, Switch × 8, Buzzer
CPU	: 64 bits/266MHz PowerPC RISC Processor
Emulation	: PostScript Level 3, PDF Ver.1.3 (optional HDD required) Kanji fonts 2Style (Heisei Gothic W5, Heisei Mincho W3)
Built-in fonts	: European fonts 137 PostScript fonts Boot ROM (512 KB), Program ROM (16 MB), EEPROM (512 MB)
Memory	: B), SDRAM DIMM128 MB (2 memory slots, maximum 512 MB),
Interface	: Ethernet (10Base-T/100Base-TX) Parallel (Centronics/IEEE-1284) USB (USB Rev. 1.1)
Network Protocol	: TCP/IP, IPX/SPX, EtherTalk
Optional Expansion Memory	: 128 MB, 256 MB Type SDRAM DIMM, PC-133, 168pin, no ECC, Non-buffered, CL=3
Optional HDD	: 30 GB Type 2.5 inch IDE disk, PIO Mode 4/UDMA 66

2. PRECAUTIONS FOR INSTALLATION

2-1. Installation Site

To ensure safety and utmost performance of the printer, the printer should NOT be used in a place:

- Where it will be subjected to extremely high or low temperature or humidity.
- Where it will be subjected to sudden fluctuations in either temperature or humidity.
- Is subject to direct sunlight.
- Which is in the direct air stream of an air conditioner, heater, or ventilator.
- Which has poor ventilation or is dusty.
- Which does not have a stable, level floor or where it will receive excessive vibration.
- Which is near any kind of heating device.
- Which is near volatile flammables (paint thinner, gasoline, etc.).
- Where it may be splashed with water.
- Which puts the operator in the direct stream of exhaust from the printer.
- Where ammonia gas might be generated.

2-2. Power Source

- If any other electrical equipment is connected to the same power outlet, make sure that the capacity of the outlet is not exceeded.
- Use a power source with minimal voltage fluctuation.
- Never connect to the outlet by means of a multiple socket, power strip or any other appliances or devices.
- Ensure that the printer does not rest on the power cord or communication cable of other electrical equipment, and that cords do not become wedged into or underneath the device.
- Make the following checks at frequent intervals:
 - * Is the power plug abnormally hot?
 - * Are there any cracks or scrapes in the cord?
 - * Has the power plug been inserted fully into the outlet?
 - * Does anything, including the printer itself, rest on the power cord?

Use an outlet with a capacity of 120 V, 12 A or more. 220-240 V, 6.5 A or more.

2-3. Grounding

- Always ground the printer to prevent electrical shock in the event of an electrical short.
- Connect the ground wire to the ground terminal of the outlet or a grounding contact which complies with local electrical codes.
- To avoid the risk of fire or electrical shock, never connect the ground wire to a gas pipe, the ground wire for a telephone, a lightning rod, or a water pipe.

2-4. Space Requirements

- To ensure easy machine operation, replacement of consumables, and maintenance service job, provide the following space for the installation of the machine.

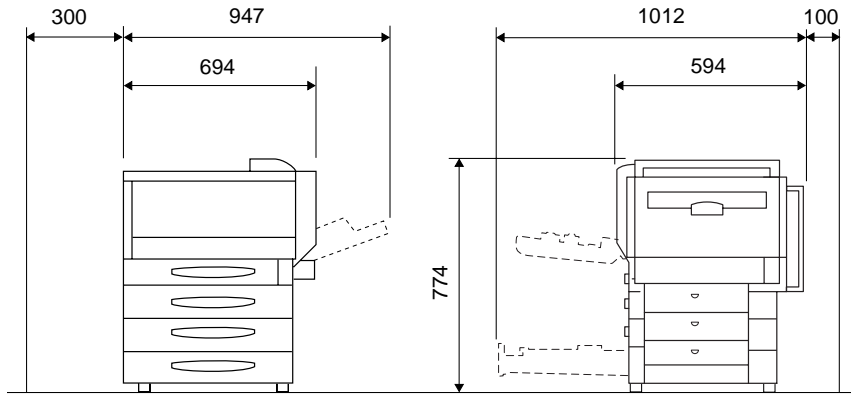

Unit: mm

4134G003AA

3. PRECAUTIONS FOR USE

3-1. To ensure that the printer is used in an optimum condition

- never place heavy objects on the printer or subject the printer to shocks.
- Insert the power plug all the way into the outlet.
- Never remove secured panels or covers while the unit is printing.
- Never turn off the unit while it is printing.
- Provide good ventilation when using the printer in a confined space for a long period of time.
- Never use flammable sprays near the printer.
- If the printer becomes exceptionally hot or produces abnormal noise, turn it off and unplug it.
- Do not turn on the power switch at the same time that you plug the power cord into the outlet.
- When unplugging the power cord, do not pull on the cord; hold the plug and pull it out.
- Do not bring any magnetized object near the printer.
- Do not place a vase or vessel containing water on the printer.
- Be sure to turn off the power switch at the end of the workday or upon power failure.
- Use care not to drop paper clips, staples, or other small pieces of metal into the printer.

3-2. Operating Environment

The operating environmental requirements of the printer are as follows.

- Temperature: 10-32.5°C
- Humidity: 15-85%
- Rate of temperature change: 10°C/h, 50° F/h
- Rate of humidity change: 20% RH/h

3-3. Power Requirements

The power source voltage requirements are as follows.

- Voltage fluctuations AC 120, 220-240 V \pm 10%
- Frequency fluctuations 50-60 Hz \pm 3 Hz

3-4. Other Precautions

Use the following precautions when performing service on a printer that uses a laser.

- When servicing parts in the path of the laser beam (near the Print Head or PC drum), be sure to first unplug the power supply cord for the unit.
- If the service requires that the power cord be left plugged in, observe the following precautions.
 1. Remove your watch, rings and any other reflective objects and wear laser protective goggles.
 2. Keep other personnel away from the service area.
 3. Do not bring a highly reflective tool into the laser beam path during servicing.

4. HANDLING CONSUMABLES

Before using any consumables, always read the container label carefully.

- Paper can be easily damaged by dampness. To keep paper that has been removed from the wrapper as dry as possible until it is loaded to the printer, store in a sealed plastic bag in a cool, dark place.
- Keep consumables out of the reach of children.
- Do not touch the PC Drum with bare hands.
- The same sized paper is of two kinds, short grain and long grain. Short grain paper should only be fed through the printer crosswise, long grain paper should only be fed lengthwise. The packing material will be marked.
- If your hands become soiled with toner, wash them with soap and water.
- Do not throw away any used consumables or used parts, as they should be collected.
- Do not burn, bury, or pour any consumables down the drain.
- Do not store consumables in a place which:
 - * Is hot and humid.
 - * Is subject to direct sunlight.
 - * Has an open flame nearby.



5. LIST OF NAMES

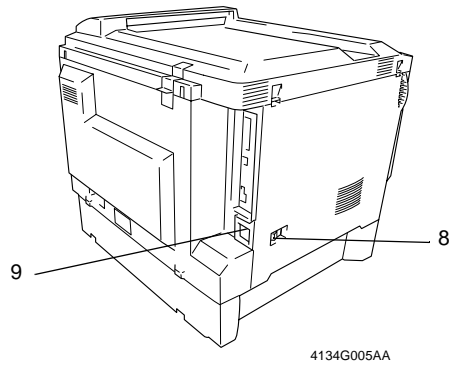
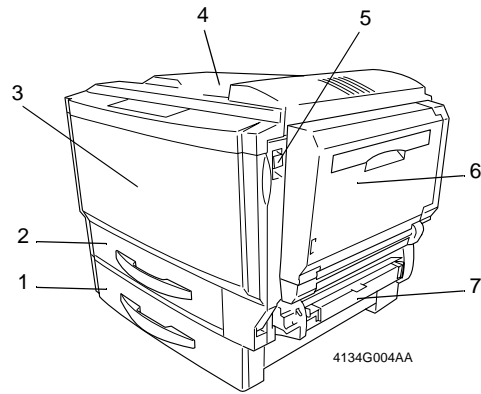

- | | |
|----------------------------------|-----------------------------|
| 1. 2nd Drawer | 9. Power Supply Cord Socket |
| 2. 1st Drawer | |
| 3. Front Door | |
| 4. Paper Output Tray | |
| 5. Right-side Door Release Lever | |
| 6. Duplex Unit (optional) | |
| 7. Manual Feed Unit (optional) | |
| 8. Power Switch | |

MECHANICAL/ ELECTRICAL



1. CROSS-SECTION VIEW

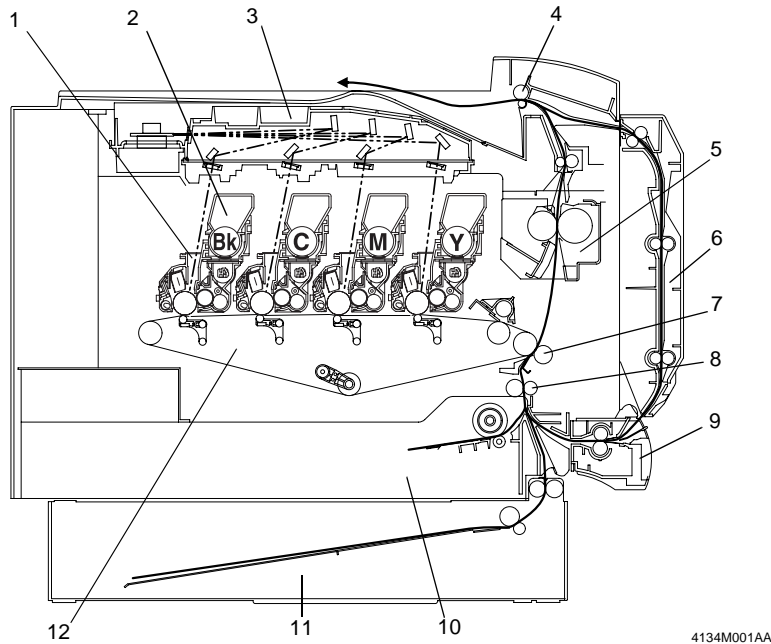

- | | |
|------------------------------|--------------------------------|
| 1. Print Unit | 9. Manual Feed Unit (optional) |
| 2. Toner Cartridge | 10. Multi-Paper Feed Drawer |
| 3. Print Head Unit | 11. Paper Feed Unit |
| 4. Paper Exit Roller | 12. Transfer Belt Unit |
| 5. Fuser Unit | |
| 6. Duplex Unit (optional) | |
| 7. 2nd Image Transfer Roller | |
| 8. Synchronizing Roller Unit | |

* Paper path

The paper feed method is a 2-way system comprised of the Multi-Paper Feed drawer (250 sheets) and the Paper Feed Unit (500 sheets).

Expandable to a 5-way system by installing up to 2 additional units: the optional Manual Feed Unit and the Paper Feed Unit (500 sheets).

- Paper fed from each Paper Feed Drawer is transported to the Vertical Transport, image transfer is then performed by the 2nd Image Transfer roller, the image is fused by the Fuser Unit and fed out face down.
- For 2-sided copying, first the 2nd side is copied and as soon as the paper moves past the Fuser Unit, the transport path is switched, the paper is turned over and is transported to the Duplex Unit.

Since a Circulating System is used, the paper is copied on the 1st side and then fed out.

2. ELECTRICAL PARTS LAYOUT

2-1. Printer

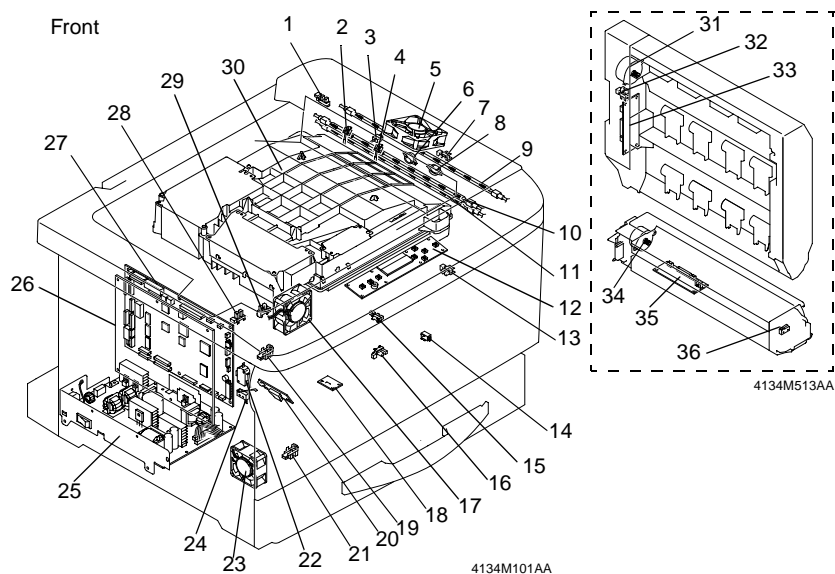

Front

- | | |
|--|---|
| 1. Exit Full Detecting Sensor (PC5) | 19. 1st Drawer Paper Size/Width Detecting Sensor (PC11) |
| 2. Heater Switch Thermistor (TH3) | 20. AIDC Sensor (PC22) |
| 3. Fusing Pressure Roller Thermistor (TH2) | 21. Waste Toner Full Detecting Sensor (PC20) |
| 4. Heating Roller Thermistor (TH1) | 22. Front Door Open/Close Detecting Switch(S2) |
| 5. Fusing Cooling Fan Motor (M24) | 23. Power Supply Cooling Fan Motor (M6) |
| 6. Heating Roller Thermostat (TS1) | 24. Front door switch (S1) |
| 7. Paper Exit Detecting Sensor (PC4) | 25. DC Power Supply (PU1) |
| 8. Fusing Pressure Roller Thermostat (TS2) | 26. Controller Board (PWB-Z) |
| 9. Fusing Pressure Roller Heater Lamp (H3) | 27. Control Board (PWB-A) |
| 10. Heating Roller Heater Lamp 1 (H1) | 28. 1st Drawer Paper Near Empty Detecting Sensor (PC9) |
| 11. Heating Roller Heater Lamp 2 (H2) | 29. 1st Drawer Set Detecting Sensor (PC7) |
| 12. Control Panel (UN1) | 30. Print Head Unit |
| 13. Loop Correction Detecting Sensor (PC3) | 31. Duplex Unit Drive Motor |
| 14. OHP Detecting Sensor (PC1) | 32. Duplex Door Detecting Sensor (PC6) |
| 15. Synchronizing Roller Front Sensor (PC2) | 33. Duplex Unit Control Board (PWB-A) |
| 16. 1st Drawer Paper Empty Detection Sensor (PC10) | 34. Manual Feed Motor |
| 17. Print Head Cooling fan motor (M8) | 35. Manual Feed Detecting Board (PWB-Y) |
| 18. Temperature/Humidity Sensor (PC21) | 36. Manual Feed Detecting Switch(S4) |

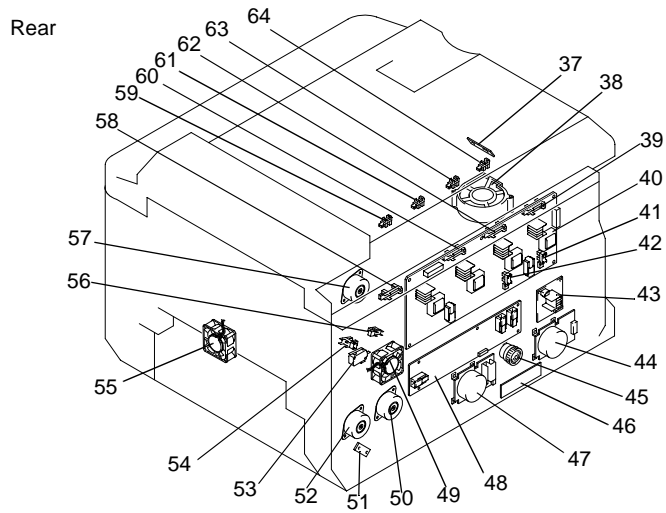

4134M102AA

- | | |
|--|--|
| 37. Registration Sensor (PC23) | 52. Transport Drive Motor (M2) |
| 38. Ozone Fan Motor (M9) | 53. Right door switch (S3) |
| 39. Toner Empty Detecting Sensor Bk (PC16) | 54. Right Door Open/Close Detecting Sensor (PC27) |
| 40. High Voltage Unit (HV1) | 55. Suction Fan Motor (M13) |
| 41. 1st Image Transfer Pressure/Retraction Detecting Sensor (PC24) | 56. 2nd Image Transfer Pressure/Retraction Detecting Sensor (PC25) |
| 42. Transfer Belt Unit Detecting Sensor (PC26) | 57. Fusing Drive Motor (M3) |
| 43. Heater Lamp Control Board (PWB-T) | 58. Drawer Empty Detecting Sensor Y (PC19) |
| 44. Print Unit Drive Motor Bk (M4) | 59. Toner Cartridge Detecting Sensor Y (PC15) |
| 45. 1st Image Transfer Pressure/Retraction Clutch (CL1) | 60. Toner Empty Detecting Sensor M (PC18) |
| 46. 1st Drawer Paper Size/Length Detecting Board (PWB-PS) | 61. Toner Cartridge Detecting Sensor M (PC14) |
| 47. Print Unit Drive Motor YMC(M5) | 62. Toner Empty Detecting Sensor C (PC17) |
| 48. High Voltage Unit 2 | 63. Toner Cartridge Detecting Sensor C (PC13) |
| 49. Print Unit Cooling Fan Motor (M12) | 64. Toner Cartridge Detecting Sensor Bk (PC12) |
| 50. Paper Feed Drive Motor (M1) | |
| 51. High Resistance Board (PWB-R) | |

2-2. Controller

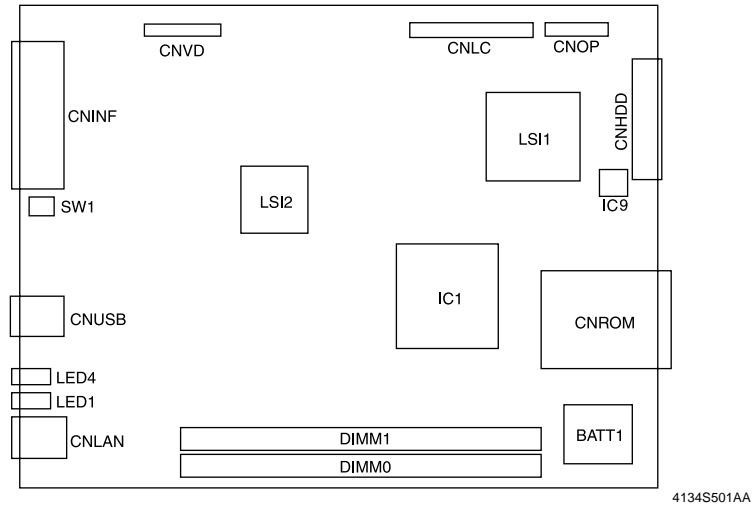

Symbol	Item	Function
CNINIF	Connector	IEEE1284 Parallel Connector
CNVD	Connector	Connector for the Print Unit
CNLC	Connector	Connector for the Control Board
CNOP	Connector	Connector for the Control Panel
CNROM	Connector	Connector for the Smart Media Card
CNHDD	Connector	Connector for the Hard Disk
CNLAN	Connector	Connector for the 10/100 Base-TX Ethernet RJ45
CNUSB2	Connector	Connector for the USB
DIMM0	Standard slot	168 pin SDRAM memory
DIMM1	Expansion Slot	168 pin SDRAM Expansion memory
BATT1	Battery	Lithium battery for clock
LED1	Light Emitting Diode (LED)	LAN Link Display LED (Amber)
LED4	Light Emitting Diode (LED)	LAN Speed Display LED (Green)
SW1	SW	CS Save (maintenance) Switch
LSI1	IC	Drawing LSI (Image data processing, control panel control, HDD control)
LSI2	IC	Correction LSI (Color match correction)
IC1	IC	CPU, Controller control
IC9	EEPROM	System Data Storage (MAC address, Counter information etc.)

3. OPERATING SEQUENCE

* Conditions: plain A4 paper, full color printing

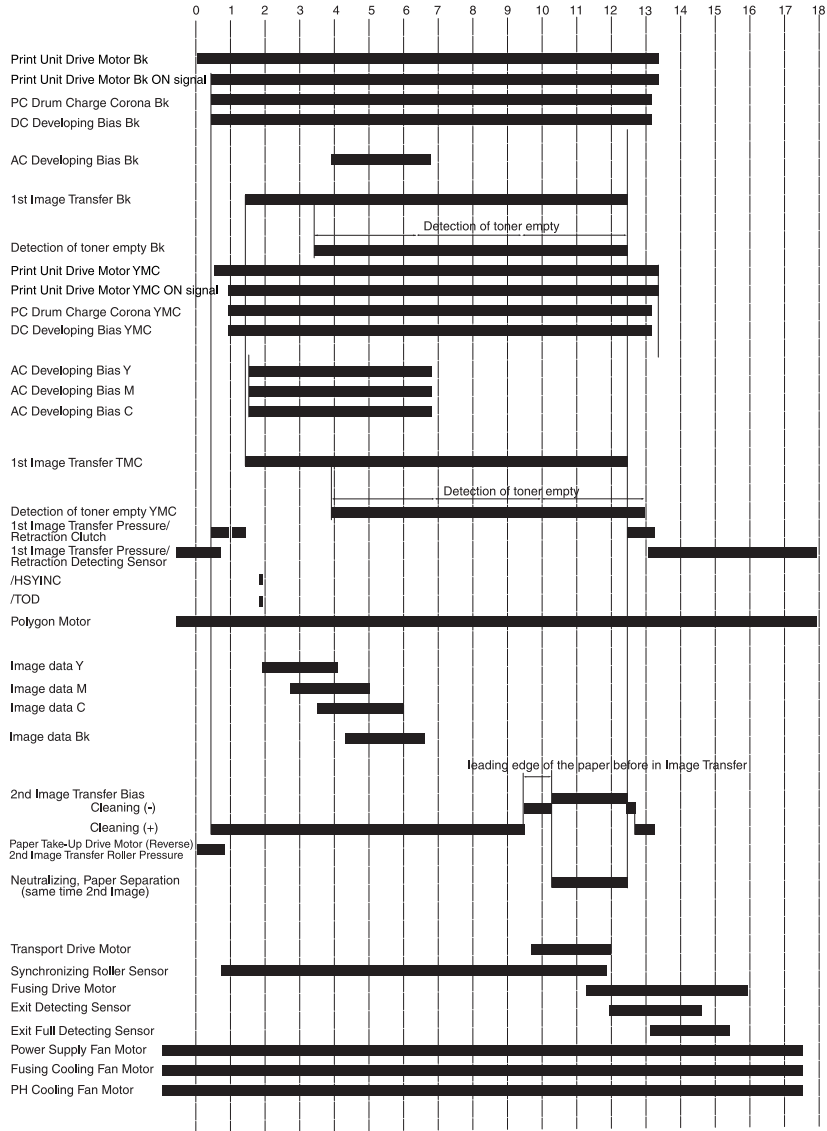

C4134S002CA

4. IMAGE STABILIZATION CONTROL

- Consistent image output can be achieved by adjusting the developing bias charge and the laser intensity. In addition, registration correction control is performed to prevent color shift.

4-1. Image Stabilization Control

- Image Stabilization Control is divided into 2 types, full correction control and simple correction control. Below is an explanation of each type of control.

	Control name	Purpose
1	Leak detection control	Set the optimum developing bias charge for the space between the PC Drum and the Developing Roller to prevent uneven density and leak images.
2	AIDC intensity control	Adjusts the intensity of the LED light to ensure a constant output value provided by the AIDC Sensor for a surface of the Image Transfer Belt, to which no toner sticks, thereby controlling variations in characteristics caused by time and contamination.
3	Maximum density control	Adjusts the pulse width ratio of the developing bias to keep constant the amount of toner sticking to the surface of the PC Drum for a 100% solid image.
4	Color shift correction control	The Registration Sensor detects the amount of color shift in the main scanning and sub-scanning directions, and adjusts laser emission timing.
5	Laser intensity control	Adjusts the intensity of the laser light to ensure constant line and gradation reproduction with changes in characteristics of the PC Drum, developing, and drum charging due to environmental changes and durability issues.
6	Gamma curve control	Makes a gradation correction by producing a pattern on the Image Transfer Belt, measuring the image density of the pattern with the AIDC Sensor, and sending the measurement results to the controller.
7	Simple correction control	1 Complete execution of Control 1 through 6 is time consuming and consumes more toner. Therefore, simple correction is executed to reduce the amount of time required and toner consumed. In addition, if correction can not be completed by simple correction, then full correction is executed.

* Full correction control is complete control 1 through 6.

4-2. Operation Timing

- Full correction control and simple correction control timing is performed as shown below.

Simple Correction Control Timing	Full Correction Control Timing
When turning the Power Switch OFF and ON.	When a substantial shift occurs after simple correction is executed
When Front Door is opened and closed	When a new Toner Cartridge is detected.
When sleep mode is cancelled.	When a new Print Unit is detected.
Printing continuous (when not in a constant environment).	When a new Transfer Belt Unit is detected.
After printing is complete (when not in a constant environment).	When a leak occurs during simple leak detection.

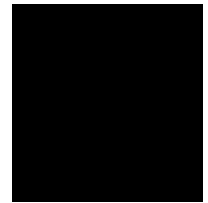

4-4. AIDC Sensor

- The AIDC sensor uses a reflective sensor to detect the amount of toner that sticks to the Image Transfer Belt. Image stabilization is performed based on the value detected.

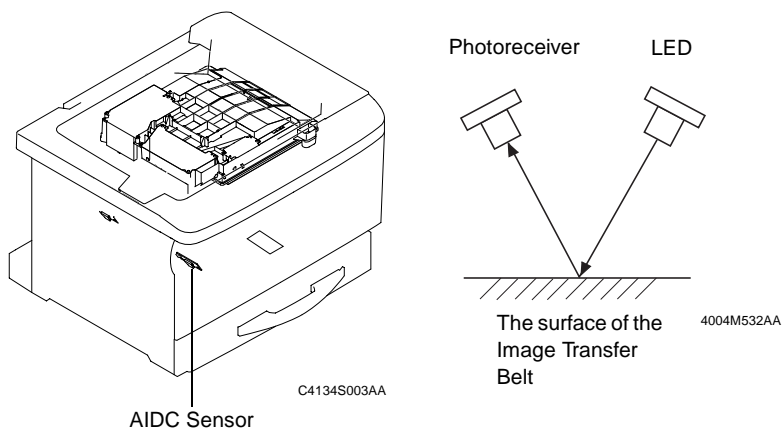

1. The light-emitting diode emits infrared rays illuminating the toner pattern on the Transfer Belt.
2. The photoreceiver detects the intensity of the infrared light reflected from the toner pattern on the Image Transfer Belt.
3. A voltage corresponding to the intensity of the reflected light is sent to the Master Board (PWB-A).

Amount of Toner Sticking	Intensity of Light Reflected	Output
Large	Small	Low
Small	Great	High

5. PRINT HEAD (PH)

5-1. System Configuration

- Four semiconductors are arranged for each color, and scanning is performed by 1polygon motor.

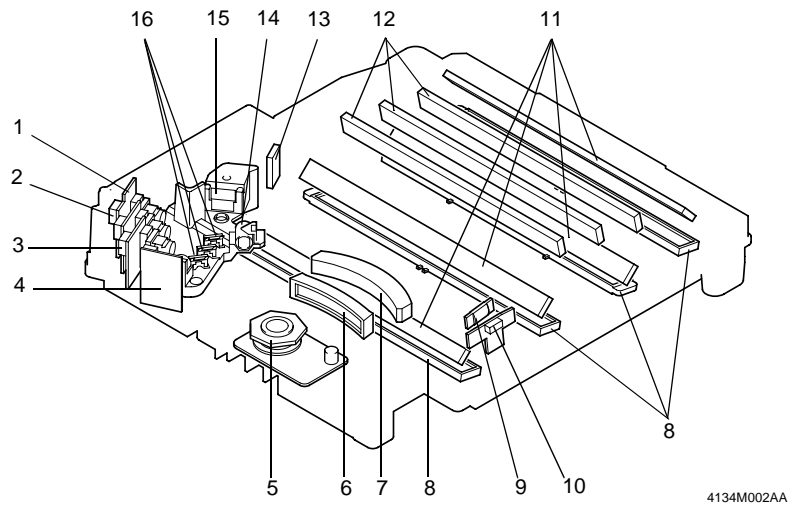

- | | |
|---------------------------|----------------------------------|
| 1. Semiconductor laser Bk | 12. Separation Mirror (BK, C, M) |
| 2. Semiconductor laser C | 13. SOS Mirror |
| 3. Semiconductor laser M | 14. Cylindrical Lens |
| 4. Semiconductor laser Y | 15. Return Mirror (light source) |
| 5. Polygon Mirror | 16. Synthetic Mirror (BK, C, M) |
| 6. G1 lens | |
| 7. G2 lens | |
| 8. G3 lens | |
| 9. SOS Lens | |
| 10. SOS Sensor | |
| 11. Return Mirror | |

5-2. Laser exposure process

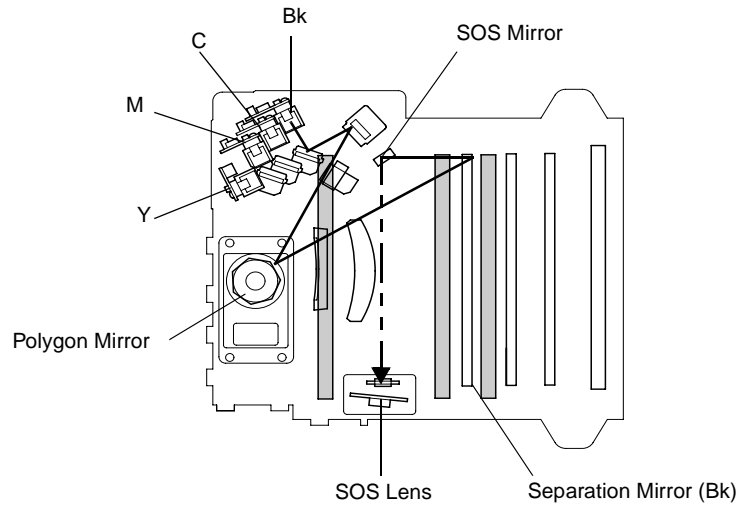

4134M030AA

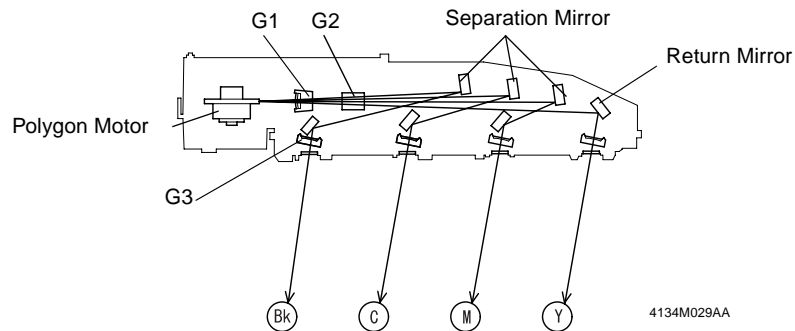

4134M029AA

1. Y The Y laser light enters the cylindrical lens via the return mirror (light source) and the C, M, Bk laser enters the cylindrical lens via the synthetic mirror and the return mirror (light source).
2. At the cylindrical lens, the sub-scanning direction of each laser light is condensed in the vicinity of the polygon mirror.
3. Since the angle of incidence for each color of laser light varies, the laser light reflected by the polygon mirror is reflected in a different angle for each color.
4. The condensing angle of each color of laser light is corrected by the G1 and G2 lenses and then reaches each return mirror.
5. Y The Y laser beam is condensed on the PC Drum via the return mirror and the G3 lens. The Bk, M and C laser beams are condensed on the PC Drum via the separation mirror, return mirror and the G3 lens.

5-3. Laser emission timing

- When Print is ON, after a fixed amount of time, the "ready" signal is detected and the laser ON signal is output.
- The laser ON signal triggers the firing of each laser beam which is illuminated onto the SOS board via the reflecting mirror → cylindrical lens → polygon mirror → G1 and G2 lenses → separation mirror → (Bk) SOS mirror and the SOS lens until an SOS signal is generated.
- This SOS signal unifies the timing in which the laser beams are radiated for each main scanning line.
- The SOS signal is only generated from the Bk laser beam but for the other colors, the emission timing is determined with Bk as a basis.

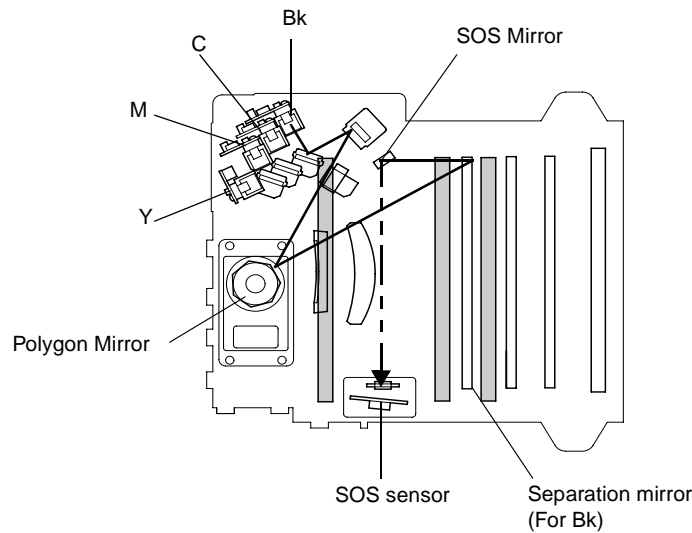

4134M030AA

5-4. Laser emission area

(1) FD Direction

- The laser print timing determines the FD print start signal (/HSYNC) that is output from the control board and the print start position for the width of the paper size.
- The laser emission area is determined by the paper size. However, 5 mm on both sides of the paper is the void image area.

(2) CD Direction

- The laser print timing determines the CD print start signal (/TOD) that is output from the control board and the print start position for the length of the paper size.
- The laser emission area is determined by the paper size. However, 5 mm at the leading/trailing edges is the void image area.

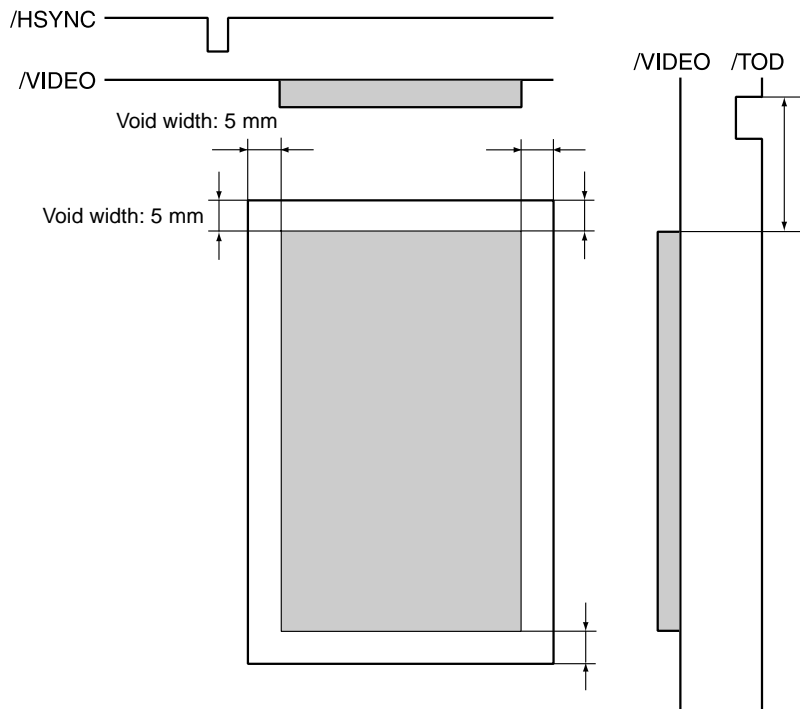

C4134S021AA

5-5. Cooling of Print Head Unit

- The PH cooling fan motor draws air from around the Print Head Unit to the outside to prevent the unit temperature from rising.

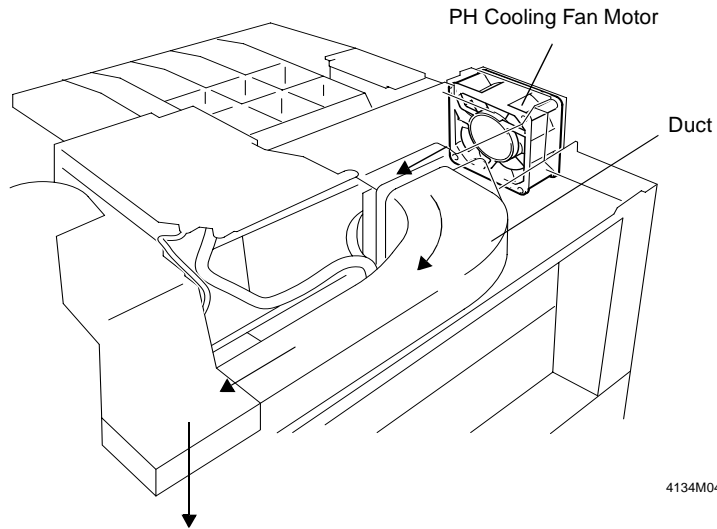

6. PRINT UNIT

6-1. System Configuration

- Each Print Unit is laid out from the left in the order of Bk, C, M, Y.
- Each of the four colors is provided with a separate reproduction process and is configured with a PC Drum, developer, cleaner, PC Drum charge and a toner cartridge.

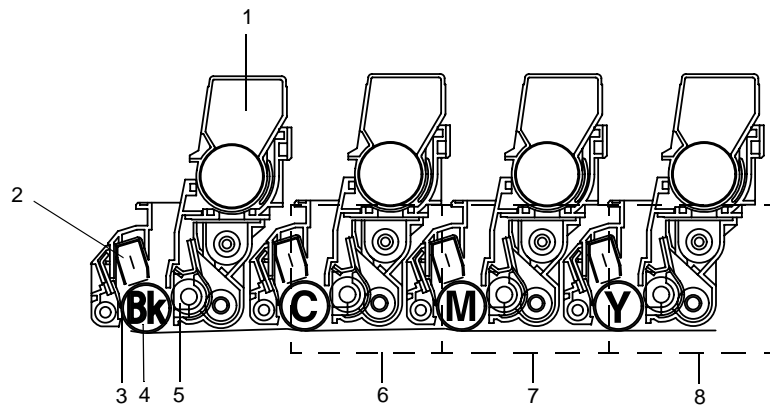

C4134S005AA

- | | |
|--------------------------|-----------------------|
| 1. Toner Cartridge (TC) | 6. Cyan Print Unit |
| 2. PC Drum Charge Corona | 7. Magenta Print Unit |
| 3. Cleaning Blade | 8. Yellow Print Unit |
| 4. PC Drum | |
| 5. Developer Roller | |

6-2. Drive Print Unit

(1) Drive Overall Unit

- The Print Unit Bk and the Image Transfer Belt provide the drive for the Print Unit Drive Motor Bk that turns the PC Drum and the Image Transfer Belt.
- Print Units C, M, and Y provide the drive for the Print Unit Drive Motor C, M, and Y that turns the PC Drum.
- In order to eliminate image noise caused by uneven rotation of the PC Drum and Image Transfer Belt, a mol gear is used to perform drive coupling.

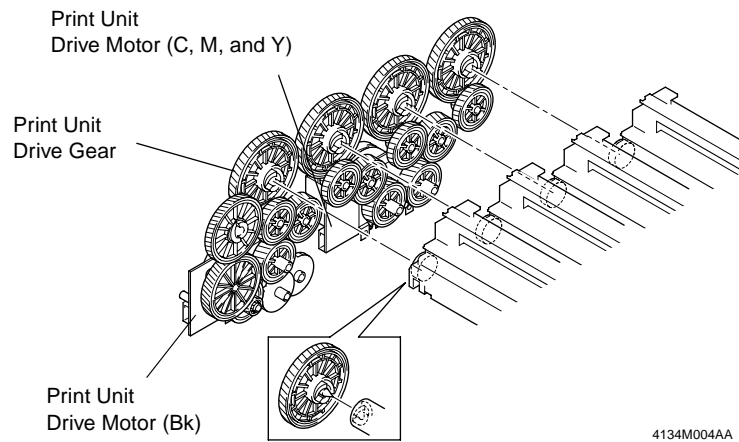

(2) Drive in Unit

- The drive in the unit rotates the waste toner transport screw by means of the PC Drum gear and then rotates the Developing Roller, Supply Roller and Paddle Roller via a Timing Belt.

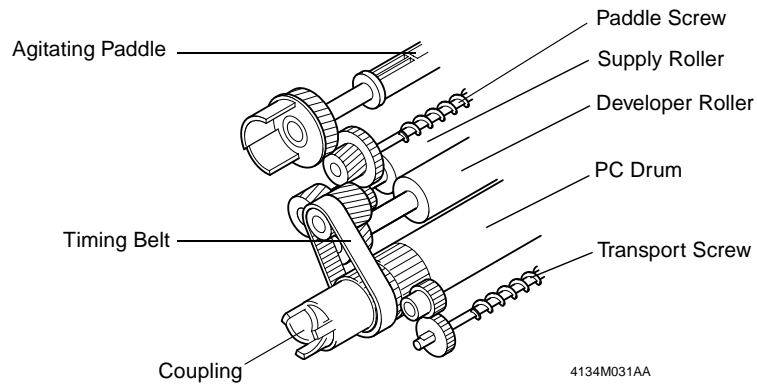

6-3. Print Unit Detection

(1) Set detection

- The set detection for each Print Unit detects whether fusing takes place from the EEPROM board when the power is OFF/ON and the front door is OPENED/CLOSED.

(2) New unit detection

- New unit detection for each Print Unit is performed by the EEPROM board.

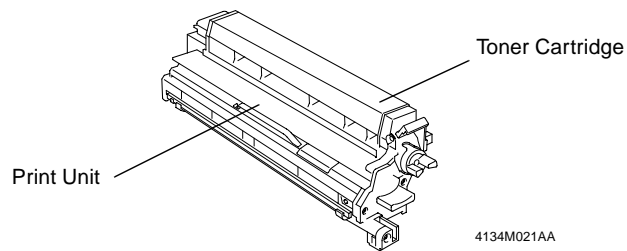

6-4. Toner Cartridge detection

(1) Set detection

- When the toner cartridge is inserted into the print unit, the cartridge pushes up against the actuator, the set detection sensor is turned ON, and the toner cartridge is detected.

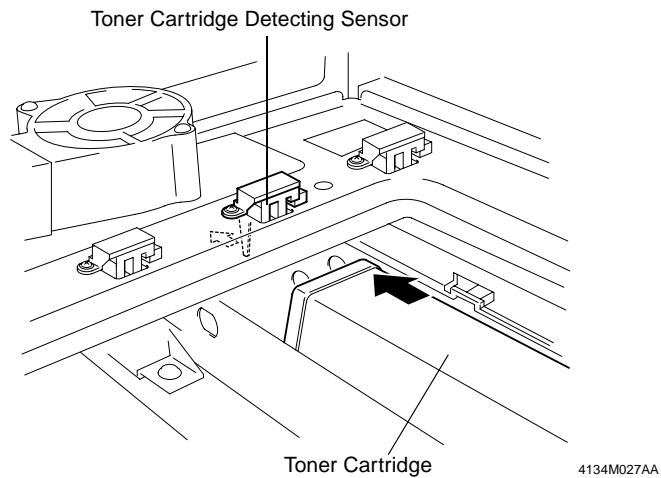

(2) New unit detection

- New unit detection is performed by energizing to the fuse in the new cartridge, and fusing.

6-5. PC Drum

- The photo conductive drum used in this printer is the organic photo conductor (OPC) type.
- * The PC Drum is laminated, coated with a carrier generation layer and a charge holding layer on an aluminum based cylinder.

Handling

If this type of PC Drum is exposed to light for a long period of time, it exhibits light fatigue which causes changes in sensitivity. Therefore, when removing the PC Drum from the printer, cover it with a clean dry cloth to protect it from the light. Also, be careful not to get dirt on the surface of the PC Drum.

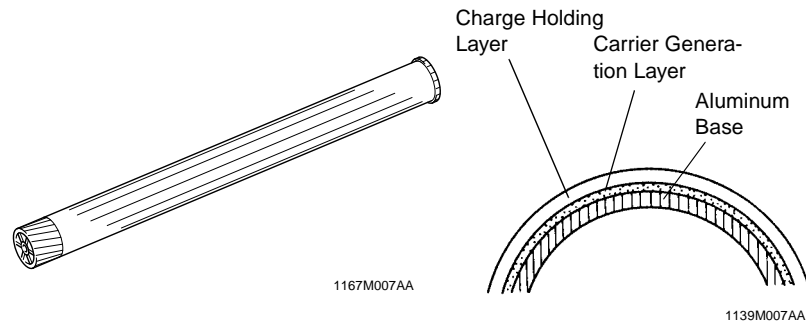

- PC Drum Ground
- * The ground contact for the PC drum is on the inside at the front of the drum and normally contacts the shaft on the front plate of the print unit. When the print unit is installed into the printer, the mounting pin on the front plate of the print unit contacts the frame of the printer. In this way, the electrical potential exposed to the PC drum is transmitted from the ground plate to the shaft and the mounting pin, and grounded with the frame.

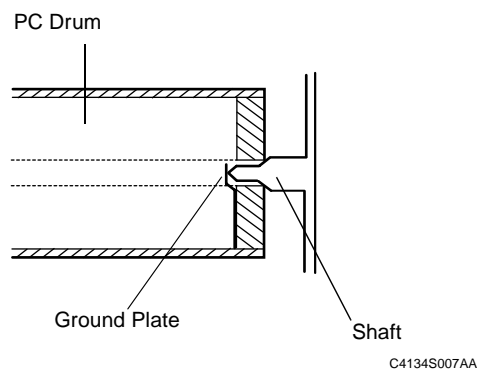

6-6. PC Drum Charging

- The PC Drum Charge Corona employs a comb electrode Scorotron charger system.
- DC(-) corona charge is applied to the comb electrode, which applies a uniform charge to the surface of the PC Drum via the grid mesh.
- Using a comb electrode ensures that a charge is concentrated on the grid mesh, thus reducing the amount of ozone produced.

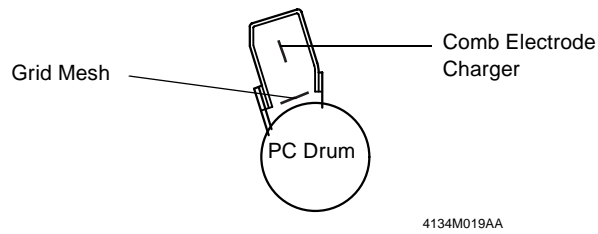
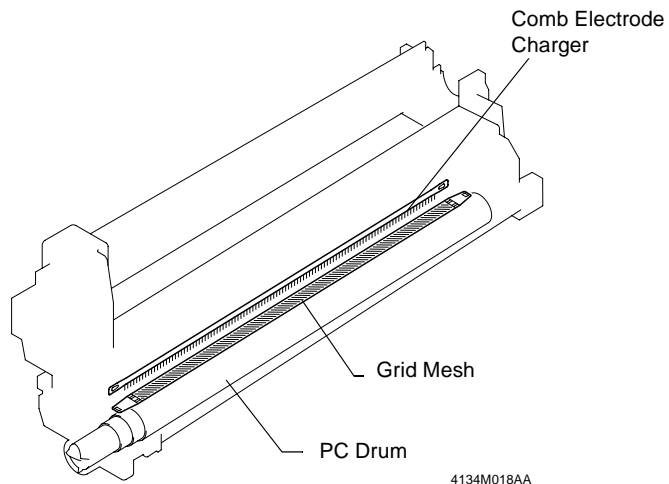

(1) Charged area Ozone Ventilation

- The ozone generated by the PC Drum charger for each color is taken in by the Ozone Fan Motor, goes through a duct in the rear and gets absorbed through the Ozone Fan Filter so that only ozone-free air is emitted from the printer.

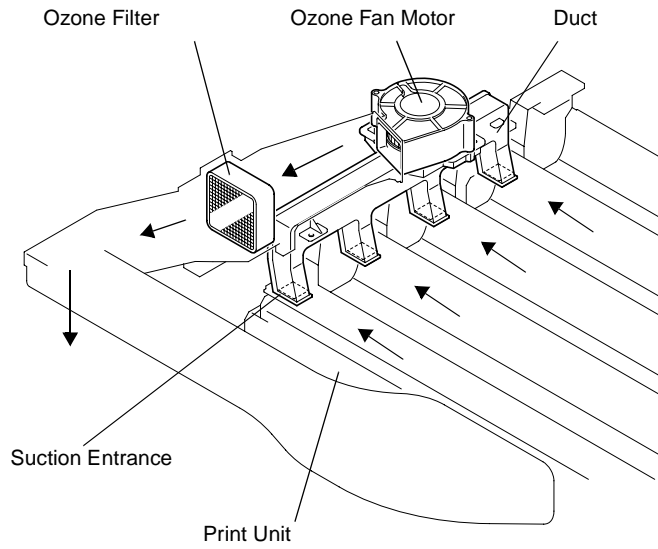

4134M020AB

6-7. Developing Section

(1) Composition

- The Toner Cartridge and Developing Unit are constructed as illustrated below.

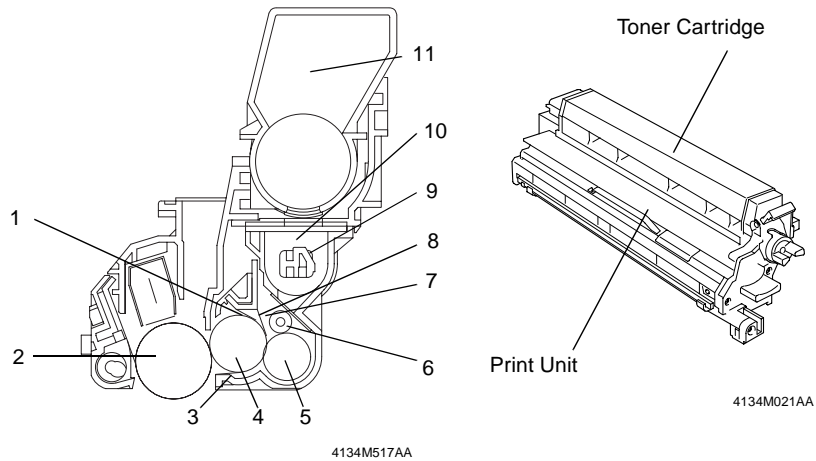

- | | |
|-----------------------------|--------------------------|
| 1. Second Regulator Blade | 8. First Regulator Blade |
| 2. PC Drum | 9. Agitating Paddle |
| 3. Charge Neutralizing Seal | 10. Hopper |
| 4. Developer Roller | 11. Toner Cartridge |
| 5. Supply Roller | |
| 6. Paddle Screw | |
| 7. Buffer | |

(2) Toner Conveyor

1. The toner drops from the toner cartridge into the hopper inside the Print Unit.
2. The Agitating Paddle mixes the toner while conveying it to the buffer.
3. The toner is then conveyed onto the Developer Roller via the paddle screw and Supply Roller.
4. The amount of toner on the Developer Roller is regulated by the 1st Regulator Blade.
5. The toner is then negatively charged by the 2nd Regulator Blade.
6. Toner sticks to the electrostatic latent image on the surface of the PC Drum.
7. The remaining toner is discharged via a charge neutralizing seal and conveyed to the Supply Roller.

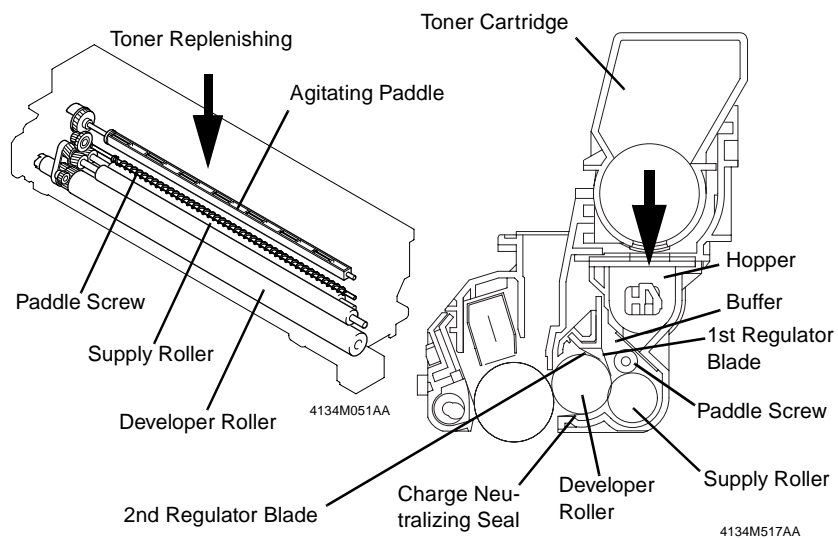

(3) Developing System

- Two types of Developing Systems are used, a non-contact developing system and an alternating current application system.
1. A negative charge is applied to the Supply Roller and toner sticks to the Developer Roller.
 2. The toner is evened out by the 1st Regulator Blade.
 3. A negative charge is applied to the 2nd Regulator Blade and the toner is negatively charged.
 4. Since an alternating current is applied to the Developer Roller, if there is negative element, the toner sticks to the PC Drum. In addition, the image density is determined by the time for the negative element.

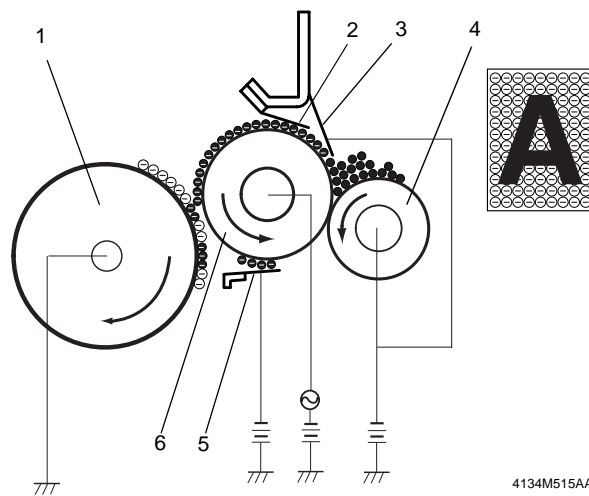

- | | |
|------------------------|-----------------------------|
| 1. PC Drum | 5. Charge Neutralizing Seal |
| 2. 2nd Regulator Blade | 6. Developer Roller |
| 3. 1st Regulator Blade | |
| 4. Supply Roller | |

(4) Toner Level Detection

Toner level detection is performed by a combination of two methods: toner consumption prediction control method and mechanical detection method 2.

1. Prediction control method

- The amount of toner consumed is computed by dot count for each color.

2. Mechanical detection method

- The amount of overlap of Disk Plate 1 attached to the Agitating Paddle shaft and Disk Plate 2 on the gear is detected by a sensor according to the excess toner on the Agitating Paddle.
- When there is a great deal of toner, the load to the Agitating Paddle increases so the amount of overlap of Disk Plate 1 and 2 increases and the amount of time the sensor is ON is reduced.
- When there is a small amount of toner, the load to the Agitating Paddle decreases so the amount of overlap of Disk Plate 1 and 2 decreases and the amount of time the sensor is ON is increased.

3. Toner Empty Detection

- The toner level is detected by the mechanical detection, the value for the amount of toner consumed is computed and fed back and toner near-empty or toner-empty is detected.
- When toner near-empty or toner-empty is detected, a message is displayed on the control panel.

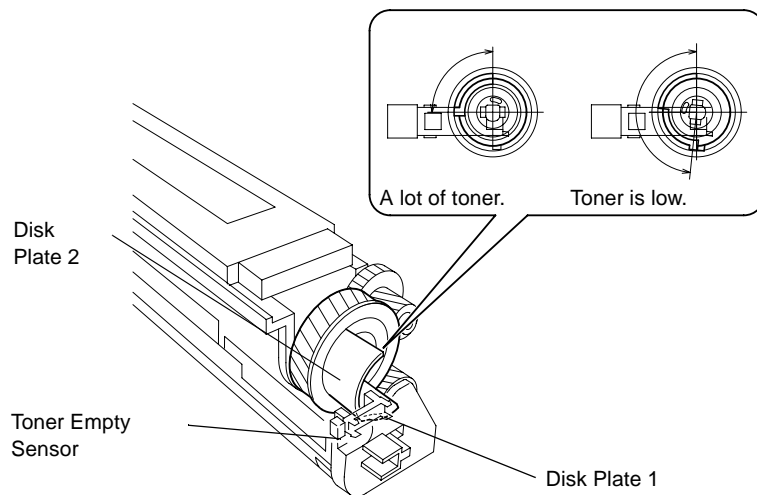

4134M023AA

(5) Toner Cartridge Shutter Open/Close Mechanism

- When the toner cartridge is installed into the print unit, the Open/Close Lever is lowered and Shutter 1 opens.

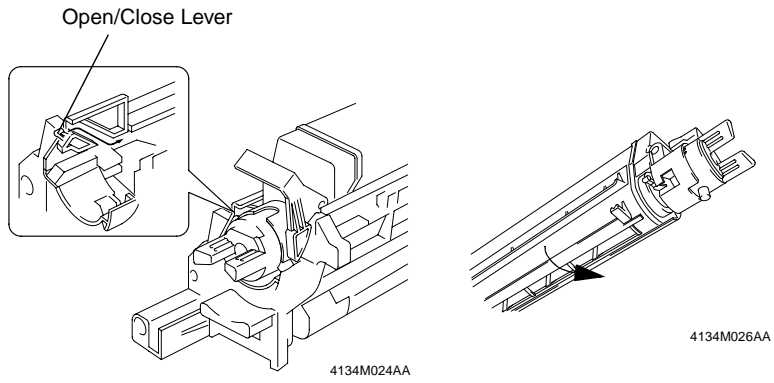

- When the knob on the toner cartridge is turned to the right, Shutter 2 opens and toner is conveyed to the Print Unit.

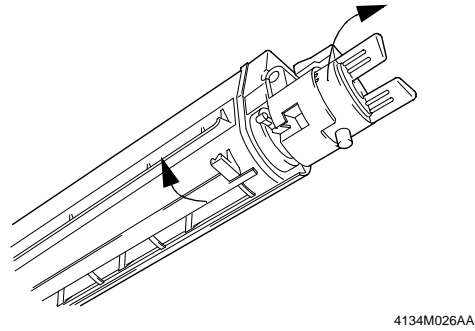

6-8. Cleaner

- The Cleaning Blade Method is used to remove the toner left on the PC Drum.
- The residual toner, which has been scraped off by the Cleaning Blade, is conveyed by the conveying screw and collected in the Waste Toner Box.

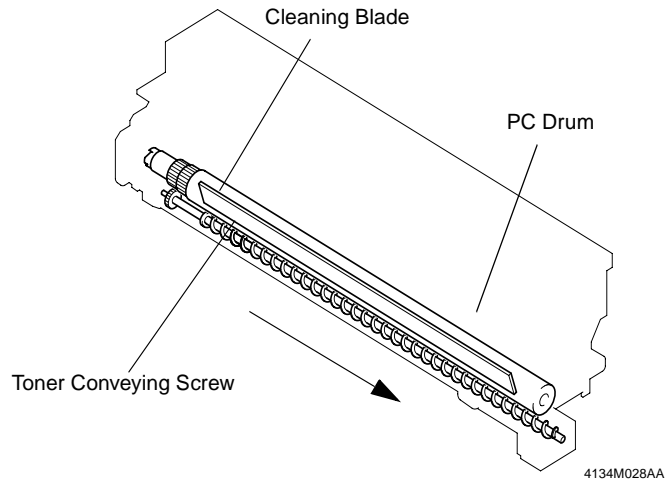

7. IMAGE TRANSFER SECTION

7-1. Construction of Transfer Belt Unit

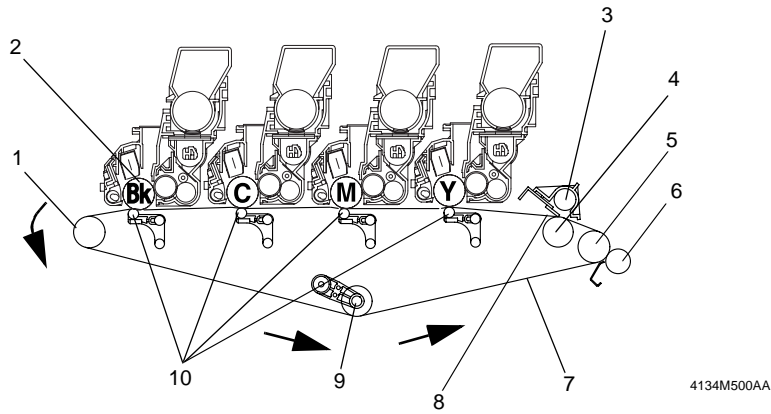

- | | |
|----------------------------------|-------------------------------|
| 1. Drive Roller | 6. 2nd Image Transfer Roller |
| 2. PC Drum | 7. Transfer Belt |
| 3. Waste Toner Conveying
Coil | 8. Cleaner Braid |
| 4. Cleaner Receive Roller | 9. Tension Roller |
| 5. Driven Roller | 10. 1st Image Transfer Roller |

7-2. Transfer Belt Unit Drive

- The Print Unit Drive Motor Bk allows the drive to rotate the drive roller via the clutch and gear.

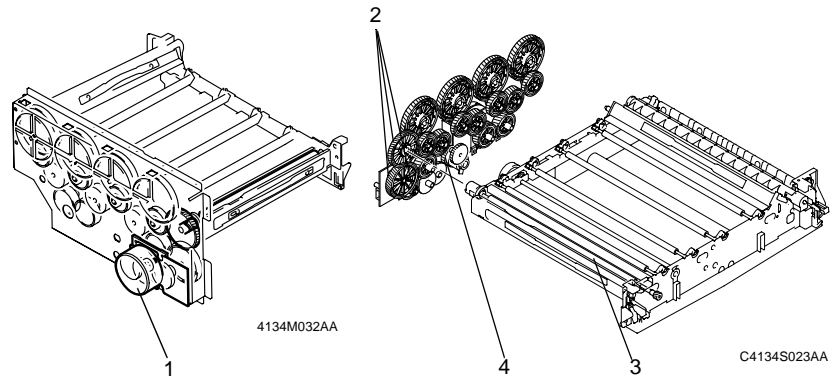

1. Print Unit Drive Motor Bk (M4)
2. Drive Gear
3. Drive Roller

4. 1st Image Transfer Pressure/Retraction Clutch (CL1)

7-3. New Transfer Belt Unit Detection

- When a new Transfer Belt Unit is installed, the Shading Plate moves in the direction of the arrow from the pressure of the 1st Image Transfer Roller and is locked into position.
- The Shading Plate moves only once.
- The Shading Plate blocks the detecting sensor and a new Transfer Belt Unit is detected.

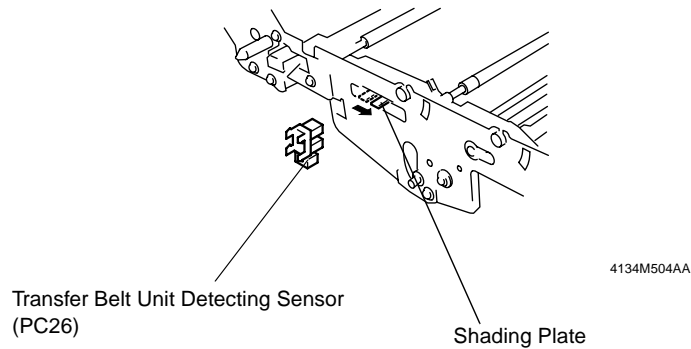

7-4. Transfer Belt Unit Set Detection

- The set detection of the Transfer Belt Unit is performed by the shading of the 1st Image Transfer Pressure/Retraction Detecting Sensor.

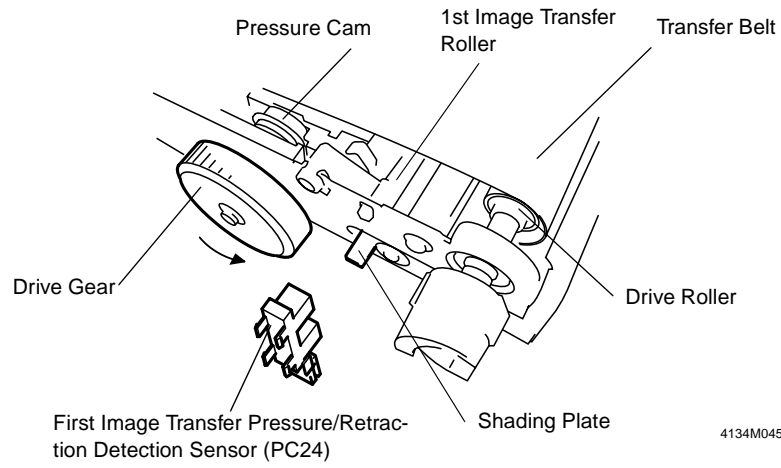

7-5. Color Shift Detection

- Patterns are produced on the surface of the Transfer Belt and the Registration Sensors detect any color misalignment on the patterns.

(1) Simple correction

- One pattern is produced in the main scanning and sub-scanning directions on the Transfer Belt.
- The pattern is the value determined by applying the last degree of correction.

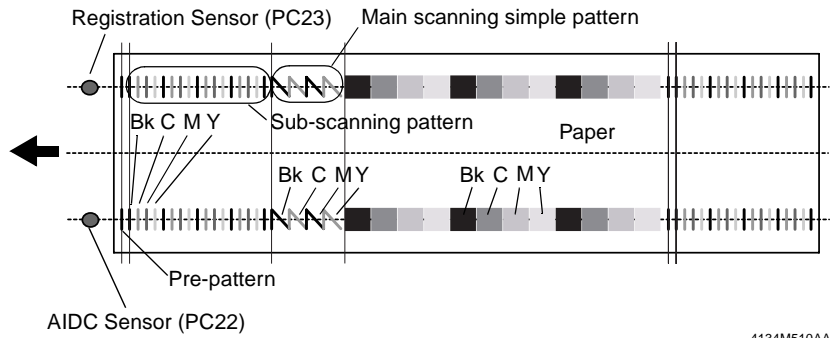

(2) Full correction

- Two patterns are produced in the main scanning and sub-scanning directions on the Transfer Belt twice.
- The pattern is the value determined by applying the last degree of correction.

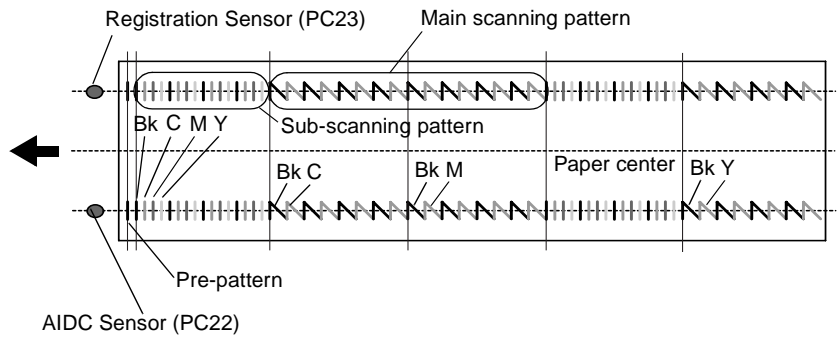

7-6. Color Shift Correction

- In a tandem engine provided with a separate image reproduction process for each of the four different colors of toner, incorrect color registration, or color shift, is more likely to occur due to positional deviations among different Print Head Units. Any misalignment among different colors is automatically detected and corrected both in the main scanning and sub-scanning directions to Bk.
- The color shift correction includes a simple correction and a full correction.

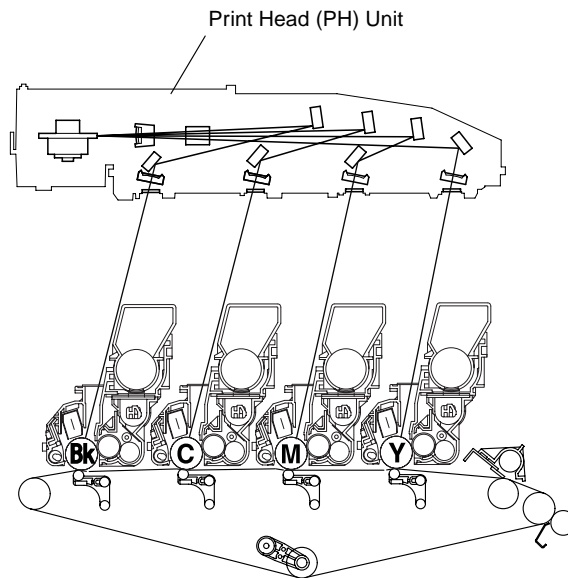

4134M507AA

Timing in which color shift is corrected

Simple correction	Full correction
1. Power Switch is turned ON.	1. When toner is supplied and a new unit is detected for the IU.
2. After cooling the machine.	2. When a substantial shift takes place after simple correction is performed.
3. After returning from sleep mode.	
4. When shifting occurs more than the constant amount.	

2. A light-emitting diode emits infrared rays illuminating the color shift pattern on the Transfer Belt.
3. The infrared light reflected from the color shift pattern is detected by the photoreceiver.
4. A voltage corresponding to the intensity of the reflected light is output to the Master Board (PWB-A).

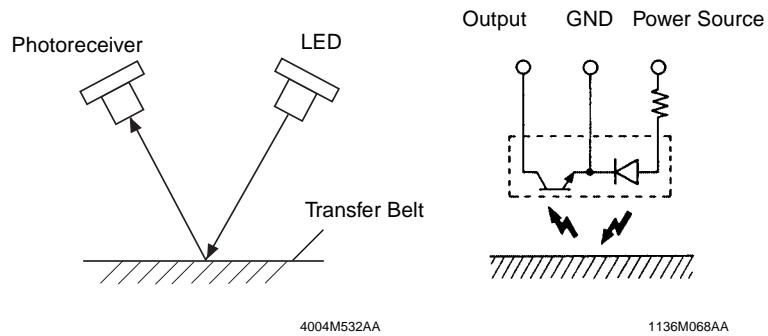
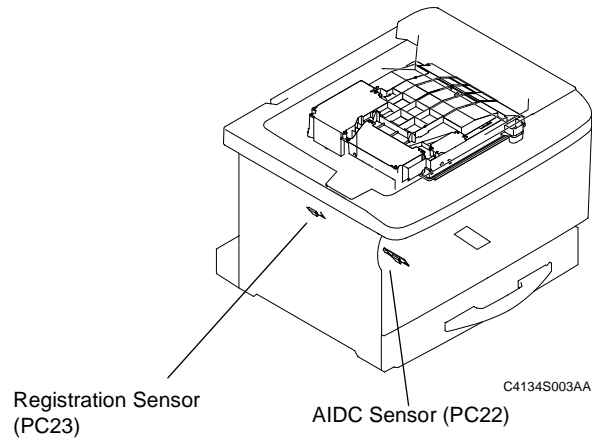

7-7. First Image Transfer Roller Pressure/Retraction Mechanism

(1) Pressure/Retraction Mechanism

- The rotation of the retraction gear causes the pressure cam to rotate and by raising the 1st Image Transfer Roller, pressure/retraction is applied to the Image Transfer Belt.
- When the 1st Image Transfer pressure/retraction clutch is ON, the rotation of the Print Unit Drive Motor Bk is relayed to the retraction gear.
- The pressure position is detected by the count of a predetermined period of time after the 1st Image Transfer Pressure/Retraction Detecting Sensor is ON.
- The retracted position is detected by the 1st Image Transfer Pressure/Retraction Detecting Sensor.

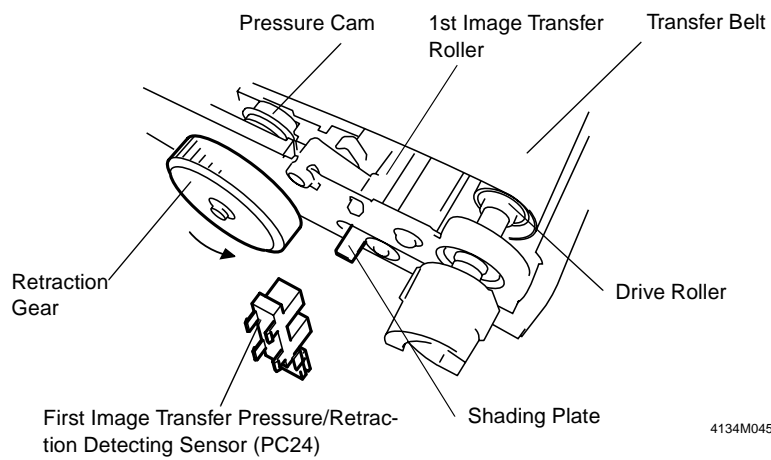

(2) Pressure Position Switching Mechanism

- To prolong the durability of the Y, M, and C PC Drums, the pressure position of the Y, M, C transfer rollers is switched with that of the Bk transfer roller when in the monochrome mode.
- The switching of the pressure position changes the stop position of the cam based on the number of motor pulses.
- In monochrome mode, only the 1st Image Transfer Roller for Bk presses against the Image Transfer Belt.
- In color mode, the 1st Image Transfer rollers for all the colors, Y, M, C, Bk, press against the Image Transfer Belt.

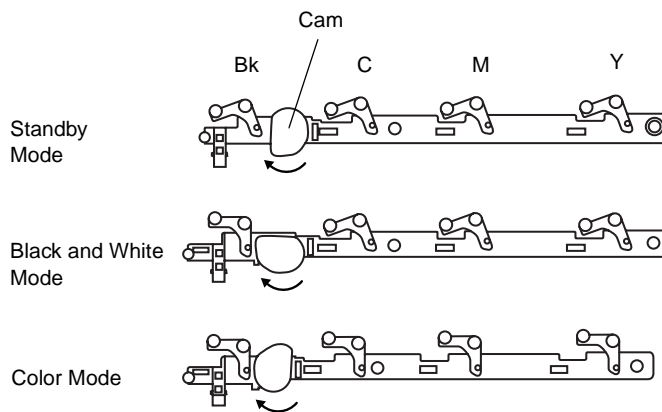

4134M035AB

7-8. 2nd Image Transfer Pressure/Retraction Mechanism

- The 2nd Image Transfer Pressure/Retraction Mechanism is performed by means of rotation of the supply Drive Motor.
- The cam rotates and the pressure lever applies pressure/retraction to the 2nd Image Transfer Roller.
- The pressure/retraction position is detected by the 2nd Image Transfer Roller Pressure/Retraction Detecting Sensor.

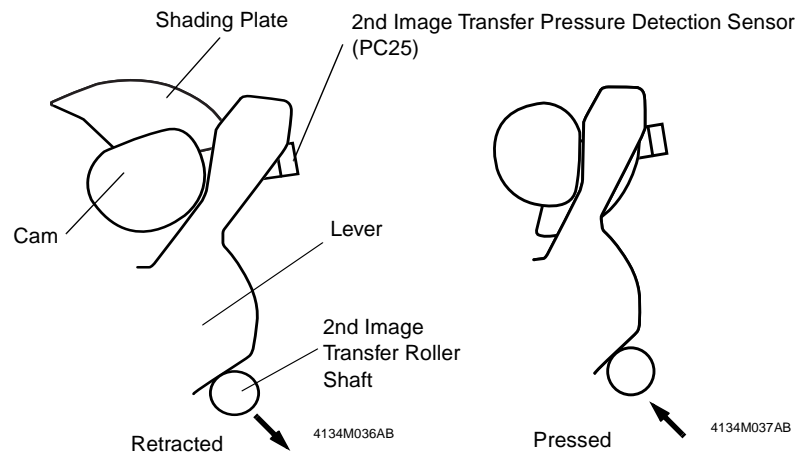

7-9. 2nd Image Transfer

- By applying the 1st Image Transfer bias, the toner image on the PC Drum is transferred to the Transfer Belt in the order of: Y, M, C, Bk.

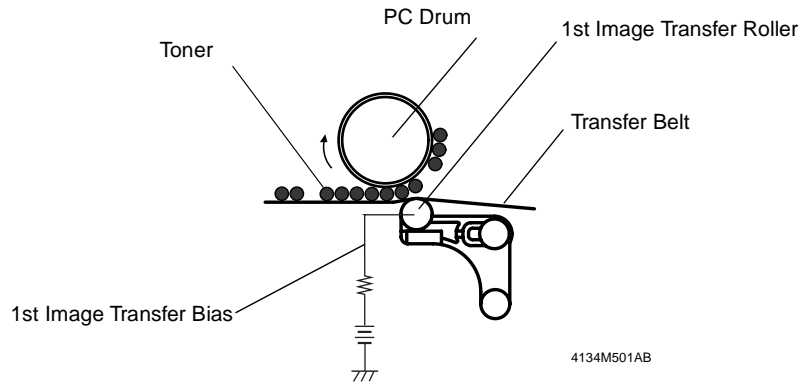

7-10. 2nd Image Transfer

- By applying the 2nd Image Transfer bias, the toner image on the Transfer Belt is transferred to the paper.

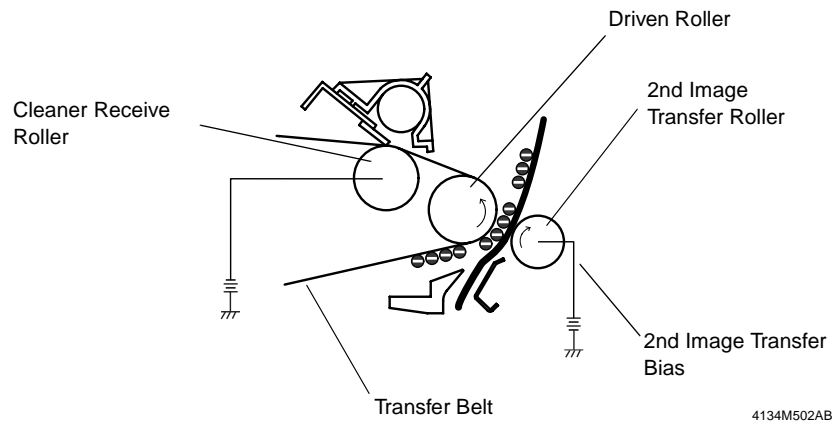

7-11. Image Transfer ATVC Control

- The resistance value of the Second Image Transfer Roller and the Transfer Belt is measured and its voltage is controlled at the appropriate level.
 - The 2nd Image Transfer ATVC adjustment is made when the Power Switch is turned ON or Front Door is opened and closed.
- * ATVC: stands for Auto Transfer Voltage Control
- The 2nd Image Transfer ATVC current is output and resistance of the 2nd Image Transfer Roller is measured.
 - The 2nd Image Transfer output current is determined according to the measured value, environment, monochrome/color mode and paper type and width.

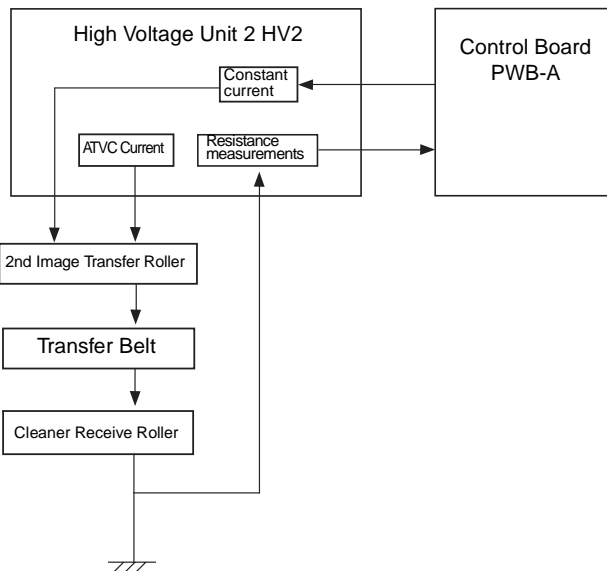
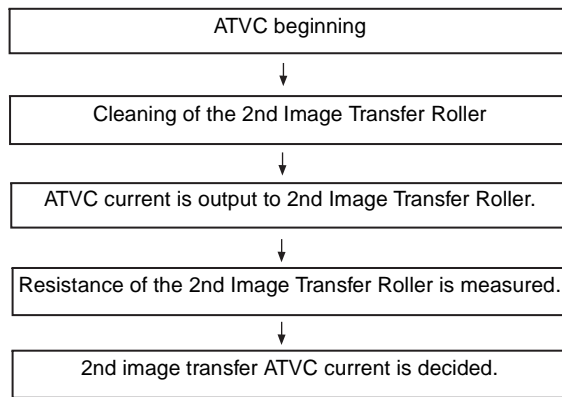

7-12. Temperature/Humidity Sensor

- The Temperature/Humidity Sensor detects the temperature and humidity inside the printer and adjusts the second image transfer bias potential.

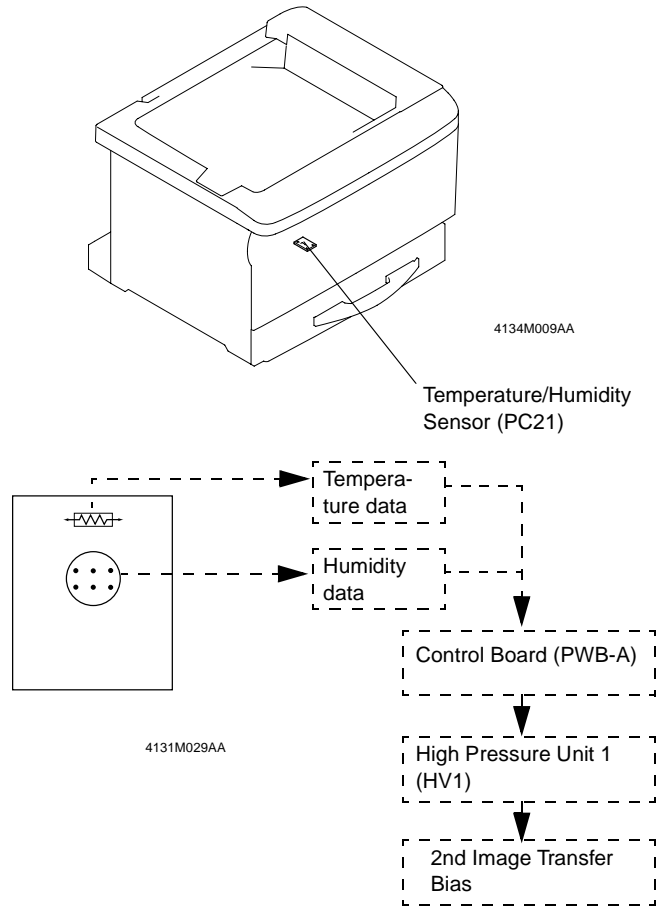

7-13. Transfer Belt Cleaning Mechanism

- The Cleaning Blade scrapes any residual toner off the surface of the Transfer Belt.
- The Cleaning Blade uses a fixed blade method in which the blade is in constant contact with Transfer Belt.
- After the power is turned ON and a predetermined number of copies are printed, the Transfer Belt is turned backward for a predetermined period of time to remove residual toner and paper dust wedged between the Cleaning Blade and Transfer Belt.

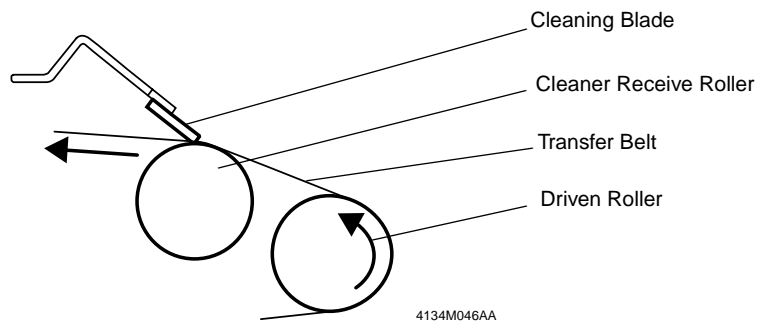

7-14. Cleaning the 2nd Image Transfer Roller

- To remove residual toner from the surface of the 2nd Image Transfer Roller, a reverse bias is output intermittently to the roller.
- The residual toner is moved to the surface of the Transfer Belt, and collected by the Cleaning Blade.
- Cleaning is initiated when the Power Switch is turned ON or Front Door is opened/closed or when jam or trouble returns occur.

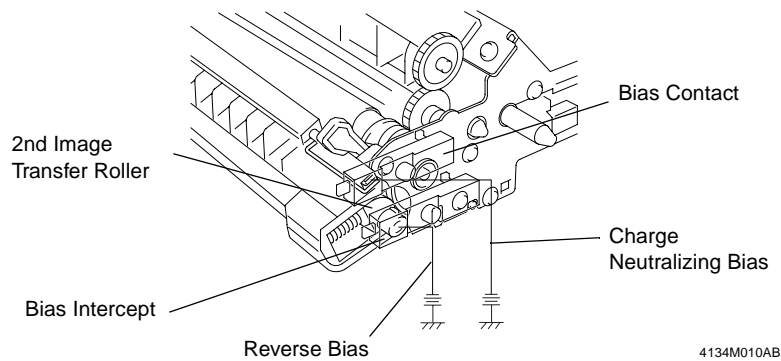

7-15. Waste Toner Box

- The Cleaning Blade scrapes any residual toner off the surface of the Transfer Belt.
- The residual toner, which has been scraped off by the Cleaning Blade, is conveyed by the conveying screw and collected in the Waste Toner Box.
- The waste toner conveying coil is rotated by the drive transmission of the driven roller.

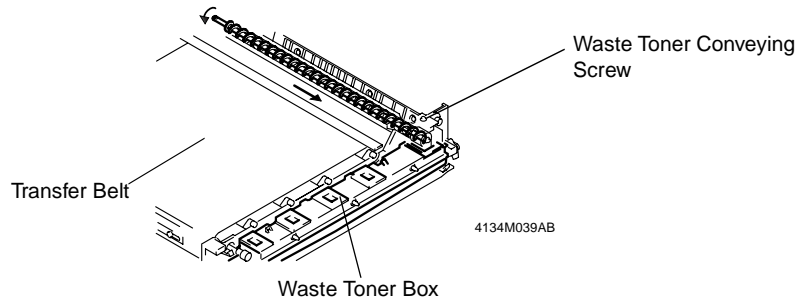

(1) Installing the Waste Toner Box

- If the Waste Toner Box has not been mounted, the front door will not shut.

(2) Waste Toner Near-Full/Full Detection

- For waste toner near-full/full detection, the amount of overlap of Disk Plate 1 attached to the agitating paddle shaft and Disk Plate 2 on the drive gear is detected by the Waste Toner Full Detecting Sensor according to the excess of toner on the agitating paddle inside the Waste Toner Box.
- When there is a small amount of toner, the load to the agitating paddle decreases so the amount of overlap of Disk Plates 1 and 2 decreases and the amount of time the sensor is ON is increased.
- When there is a great deal of toner, the load to the Agitating Paddle increases so the amount of overlap of Disk Plate 1 and 2 increases and the amount of time the sensor is ON is reduced.

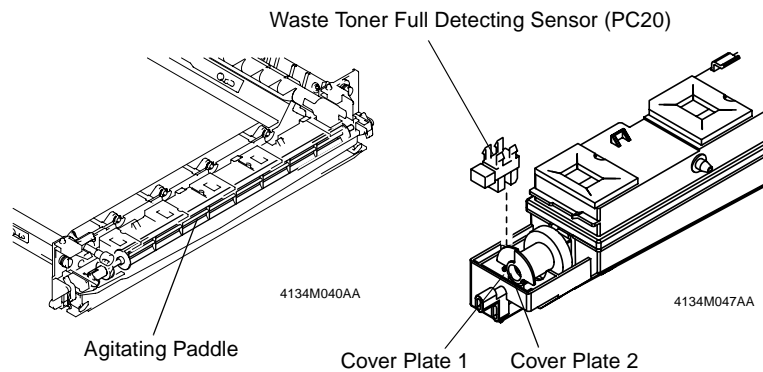

8. FUSING SECTION

8-1. Drive of Fuser Unit

- During the image transfer process, the toner is transferred and fused to the paper.
- The Fusing Method is a roll method whereby a heating roller heated by a heater lamp and fusing pressure roller are pressed and by passing paper between them, the toner becomes fused to the paper.
- The heating roller is equipped with two heater lamps, which are switched according to the paper size.

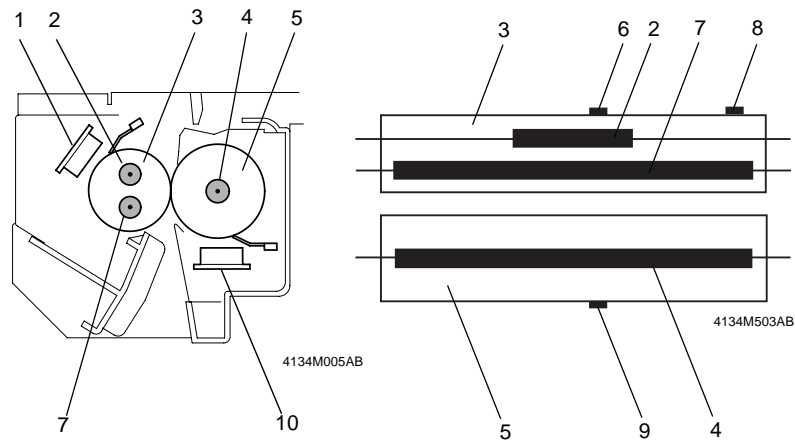

- | | |
|--|---|
| 1. Heating Roller Thermostat (TS1) | 7. Heating Roller Heater Lamp1 (H1) |
| 2. Heating Roller Heater Lamp 2 (H2) | 8. Heater Switching Thermistor (TH3) |
| 3. Heating Roller | 9. Fusing Pressure Roller Thermistor (TH2) |
| 4. Fusing Pressure Roller Heater Lamp (H3) | 10. Fusing Pressure Roller Thermostat (TS2) |
| 5. Fusing Pressure Roller | |
| 6. Heating Roller Thermistor (TH1) | |

8-2. Fuser Unit Drive

- The fusing section is driven by a motor.

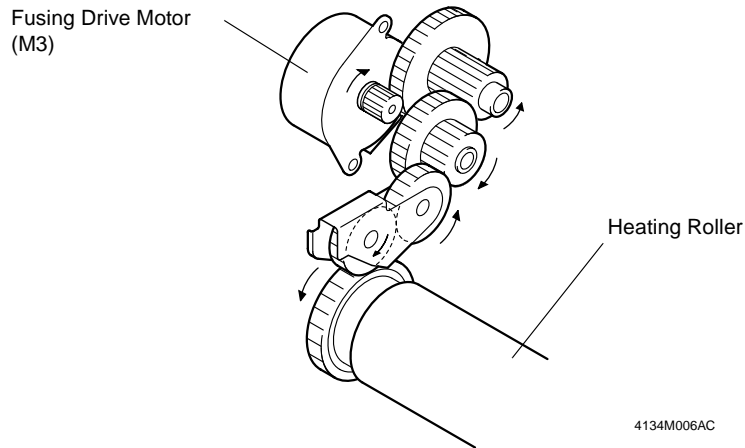

8-3. Control of Loop Before Fusing

- A loop is formed in front of the fusing roller to maintain the correct paper feed condition between the 2nd Image Transfer Roller and the fusing roller.
- The speed of the fusing Drive Motor is regulated in 2 stages to ensure that a loop is constantly being formed.
- The Loop Correction Detection Sensor switches the speed of the fusing motor.

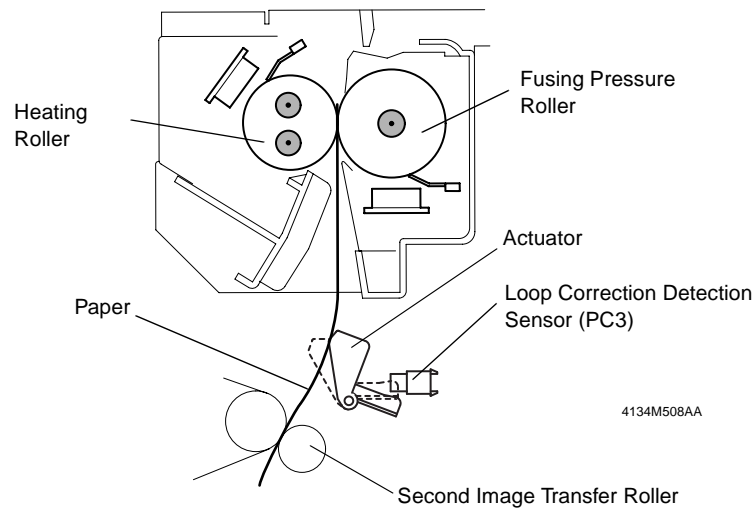

8-4. New Fuser Unit Detection

- New unit detection is performed by energizing to the fuse in the new unit, and fusing.

8-5. Pressure of Fusing Roller

- The Fusing Pressure Roller and the Heating Roller are pressed against each other at all times. They are released for maintenance service or replacement of parts.
- If a paper misfeed occurs in the Fuser Unit, the Fusing Misfeed Clearing Levers are pulled upward to release pressure between the two rollers.

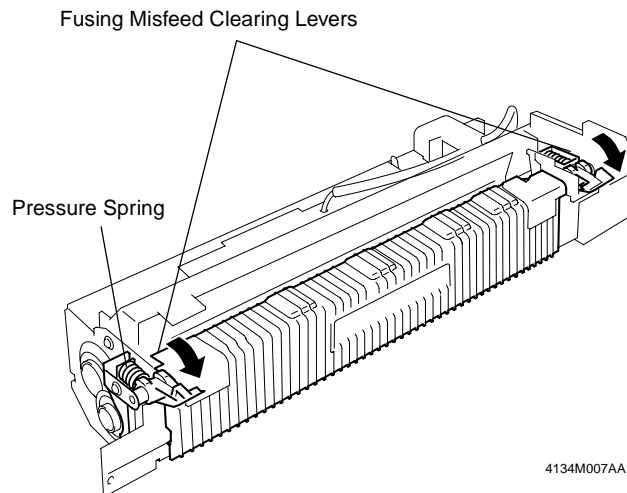

4134M007AA

8-6. Temperature Control

- Heater lamps are turned ON and OFF to keep the surface temperature of the Fusing Pressure Roller and Heating Roller at predetermined levels.
- The heating roller has two heater lamps with different heat intensity and light distribution, which are switched according to the paper size.
- The surface temperature of the heating roller and the fusing pressure roller is detected by a thermistor and the heater lamps are turned ON or OFF.
- If the surface temperatures of the Fusing Pressure Roller and Heating Roller run inordinately high, power to the heater lamps is shut down.
- When an error occurs, with the exception of "No paper", "Paper misfeed" or "size error", the power to the heater lamps is shut down.

(1) Fusing Temperature control flow

- Control is different according to the state of the engine.

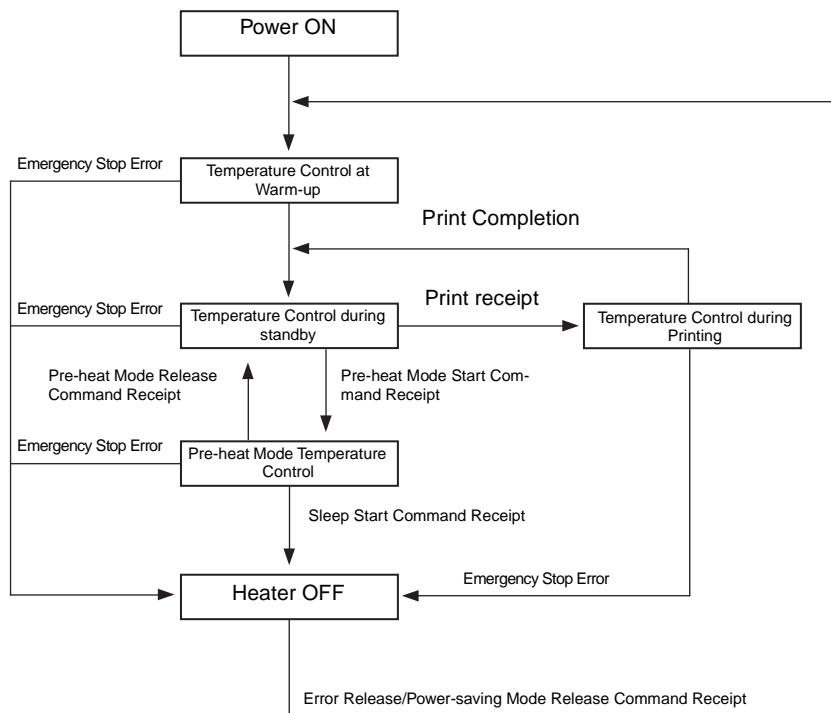

C4134S040AA

(2) Control at Warm-up

- The temperature is adjusted to the printing temperature and the heating roller and fusing pressure roller are warmed up.
- Warm-up control has two modes based on the temperature of the heating roller when the warm-up is started.

Name	Temperature of Heating Roller when initialize starts
Cold start	100 Less than 100°C
Warm start	100 More than 100°C

Control at cold start

Name	Set Temperature	Fusing Motor Start-up Conditions	Warm-up Completion Conditions	Fusing Motor Stop Conditions
Heating Roller	150°C	More than 120°C	145°C	150°C
Fusing Pressure Roller	150°C	–	145°C	150°C

Control at warm start

Name	Set Temperature	Fusing Motor Start-up Conditions	Warm-up Completion Conditions	Fusing Motor Stop Conditions
Heating Roller	150°C	More than 120°C	After the fusing motor has been driven for more than 10 seconds at more than 145°C.	After the fusing motor has been driven for more than 10 seconds at more than 150°C.
Fusing Pressure Roller	150°C	–	After the fusing motor has been driven for more than 10 seconds at more than 145°C.	After the fusing motor has been driven for more than 10 seconds at more than 150°C.

(3) Temperature Control During Standby

- During standby, after warm-up or when print is complete, the decline in temperature of the heating roller and the fusing pressure roller is controlled.

	Heating Roller temperature	Fusing Pressure Roller temperature
Within 30 sec. after warm-up ends	170°C	170°C
For Standby modes other than in the above situations	170°C	170°C

(4) Temperature Control During Printing

- Temperature control is performed for each roller based on the paper size and number of copies.

Control temperature (Heating roller/ Heating roller °C)	Plain Paper		Thick Paper	
	Paper Size	216 mm or less	More than 216 mm	216 mm or less
1st sheet	173/155	180/183	173/155	180/183
2nd through 5th sheets	165/155	170/178	165/155	170/178
6th sheet or beyond	158/155	165/165	158/155	165/165

Control temperature (Heating roller/ Heating roller °C)	OHP	Double sided (plain paper)	
		Paper Size	216 mm or less
1st sheet	171/171	173/155	180/165
2nd through 5th sheets	170/170	165/155	170/155
6th sheet or beyond	170/170	158/155	170/155

(5) Pre-heat Mode Control

- The temperature of the heating roller and fusing pressure roller is lowered to reduce the amount of electricity consumed during standby.
- The temperature is controlled so that the appropriate printing temperature is achieved within 30 seconds.
- When the pre-heat completion message is received, the printer moves to standby control mode.

Name	Set Temperature
Heating Roller	138°C
Fusing Pressure Roller	132°C

(6) Sleep Mode

- When the sleep mode start command or power saving start mode command given, the printer goes into this mode.
- Both the heating roller and fusing pressure roller turn OFF to reduce the amount of power consumed.
- When the sleep mode completion or power saving mode completion commands are given, the printer goes into warm-up control.

(7) Heating heater switch control

- The control begins from Heater 1 when the Power Switch is turned ON.
- This control is continuously performed while the heater is ON.

	During warm-up	Within 30 sec. after a warm-up cycle	Standby
Switch to Heater 2	Target Control Temperature +15°C		Target Control Temperature +2°C
Switch to Heater 1	Target Control Temperature -2°C		Target Control Temperature -2°C

Print mode	One-sided Printing		
Paper type	Plain Paper, Thick Paper		
Paper width	Less than 216 mm	More than 216 mm	
Number of continuous copies	All sheets	1st sheet	After the 2nd sheet
Switch to Heater 2	Select only Heater 2	Target Control Temperature -6°C	Target Control Temperature -10°C
Switch to Heater 1	Select only Heater 2	Target Control Temperature -10°C	Target Control Temperature -14°C

Print mode	Two-sided Printing		
Paper type	Plain Paper		
Paper width	Less than 216 mm	More than 216 mm	
Number of continuous copies	All sheets	1st sheet	After the 2nd sheet
Switch to Heater 2	Select only Heater 2	Target Control Temperature -6°C	Target Control Temperature -10°C
Switch to Heater 1	Select only Heater 2	Target Control Temperature -10°C	Target Control Temperature -14°C

Print mode	One-sided Printing
Paper type	OHP
Paper width	
Continuous number of copies	All sheets
Switch to Heater 2	Target Control Temperature +2°C
Switch to Heater 1	Target Control Temperature -2°C

9. PAPER TAKE-UP SECTION

9-1. 1st Drawer

- The 1st drawer holds 250 sheets of plain paper/50 sheets of thick paper, government-standard postcards and transparencies, or 10 envelopes.

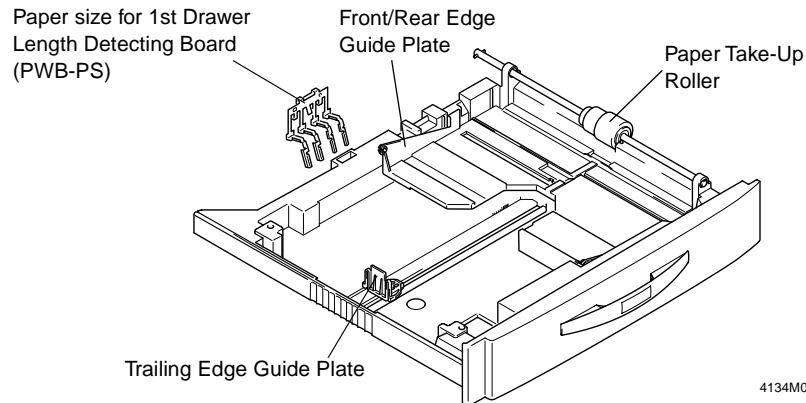

(1) Tray set detection

- The shading plate blocks the detection sensor and the machine then determines that the drawer has been slid into position.

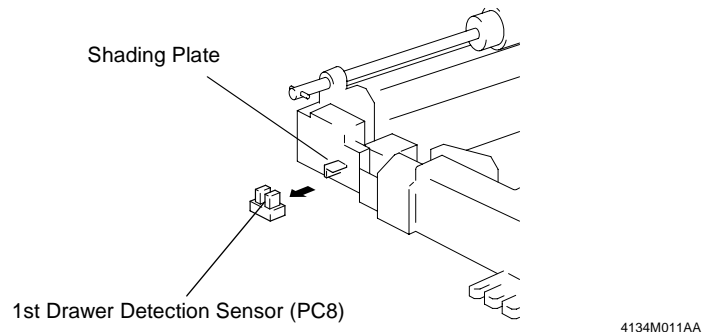

(2) Paper Size Detection

- The paper size is detected by a combination of four length detection switches and a width detection sensor.

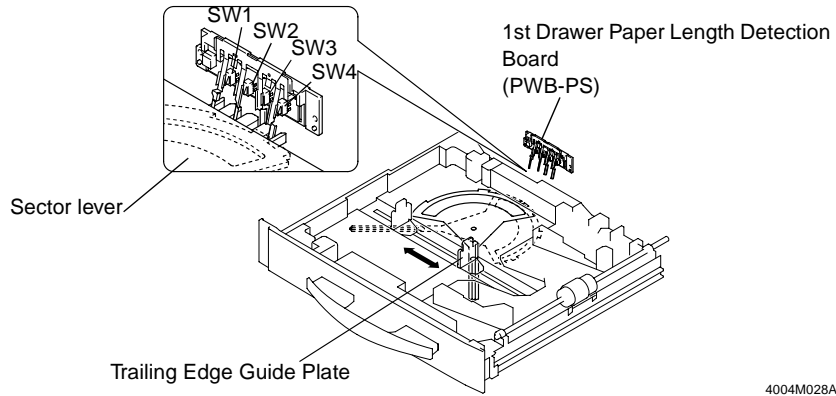

4004M028AB

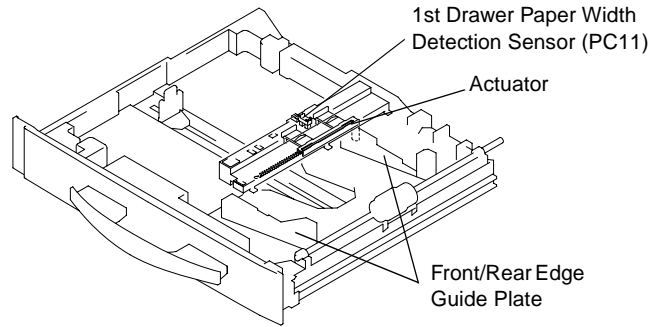

4134M050AB

Paper size	Length Detecting Switch (PWB-PS)				Size Detecting Sensor (PC11)
	SW1	SW2	SW3	SW4	
Postcards	ON	OFF	ON	OFF	ON
A5C	ON	OFF	ON	OFF	OFF
B5C	OFF	ON	OFF	ON	ON
Letter C	OFF	OFF	ON	OFF	ON
A4C	OFF	OFF	ON	OFF	OFF
G.Legal L	ON	OFF	OFF	OFF	OFF
Legal L	ON	ON	ON	OFF	OFF
B4L	ON	ON	ON	OFF	ON
Ledger L	ON	ON	ON	ON	ON
A3L	ON	ON	ON	ON	OFF
Oversized L	OFF	ON	ON	ON	OFF

(3) Paper Near-empty Detection

- When the number of sheets of paper still available for use reaches a predetermined level, the printer determines that it is a paper-near-empty condition.

	Predetermined No. of Sheets (Paper Level)
Near Empty	50±20 sheets (80 g/m ² paper)

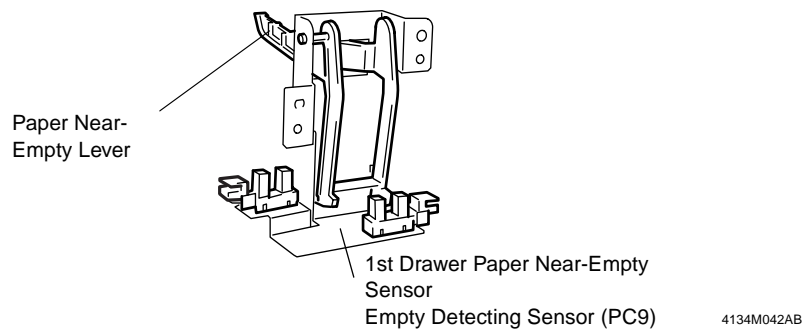

(4) Paper Empty Detection

- The Paper-empty condition is detected by the Paper Empty Detecting Sensor.

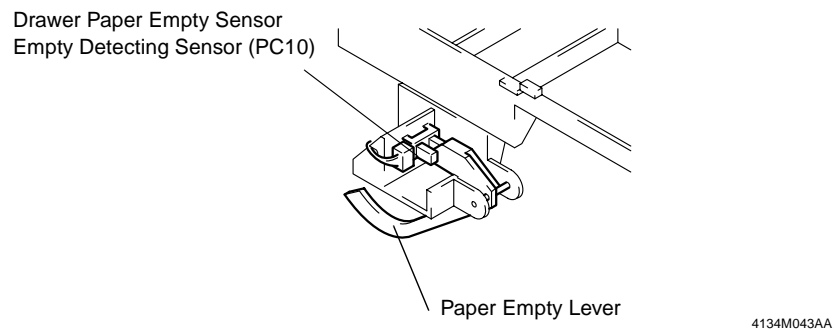

(5) Paper Take-Up Mechanism

- The Paper Take-Up Roller drives the Paper Take-Up Drive Motor via a gear.
- A Paper Separator Roller is used to prevent double feed.

Paper Take-Up Drive Motor (M1)

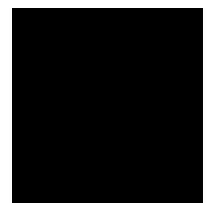
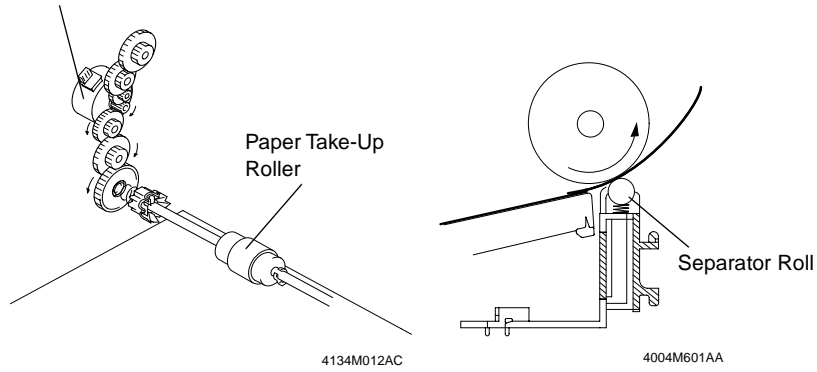

9-2. 2nd Drawer

- The 2nd Drawer holds up to 500 sheets of plain paper.
- Up to two optional cassettes can be added.

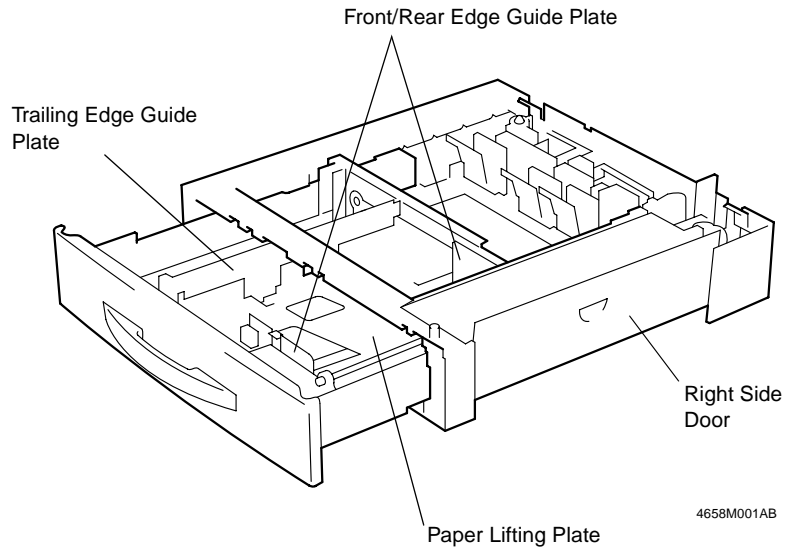

(1) Tray set detection

- When the cassette is slid in, the rib actuates the switch, allowing the machine to determine that the cassette has been slid in position.

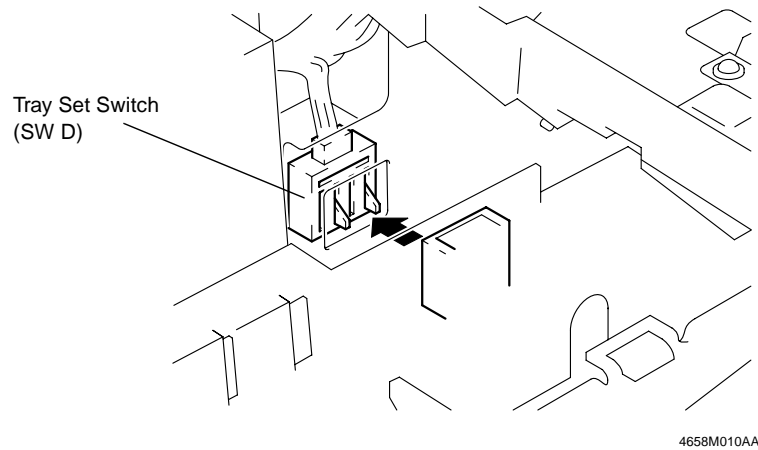

(2) Paper Size Detection

When the cassette slides in, the Front/Rear and Trailing Edge Guide Plates actuate the Paper Size Detection Switch allowing the machine to determine the paper size.

Paper Size	SW A				SW B				SW C			
	FD1	FD2	FD3	FD4	FD5	FD6	FD7	FD8	FD9	FD10	FD11	CD1
Ledger L	H	H	H	H	H	H	H	H	H	H	H	L
A3L	L	H	H	H	H	H	H	H	H	H	H	L
B4L	H	L	H	H	H	H	H	H	H	H	H	H
Legal L	H	H	L	H	H	H	H	H	H	H	H	H
Letter C	H	H	H	H	H	H	H	L	H	H	H	L
A4C	H	H	H	H	H	H	H	H	L	H	H	L
JIS B5C	H	H	H	H	H	H	H	H	H	H	L	H

* ON: L, OFF: H

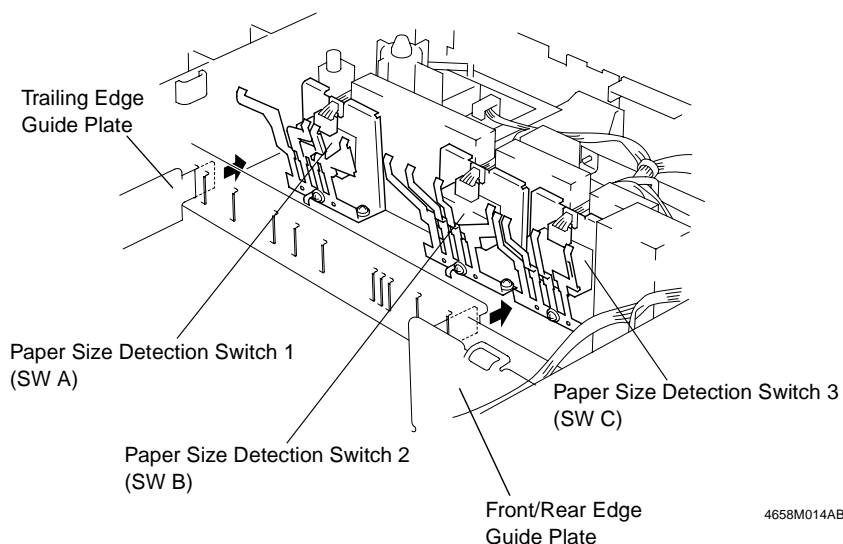

(3) Paper Empty Detection

- When the number of sheets of paper still available for use reaches a predetermined level, the printer determines that there is a paper-near-empty condition.

	Predetermined No. of Sheets (Paper Level)
Near Empty	80 ± 30sheets (80 g/m ² paper)

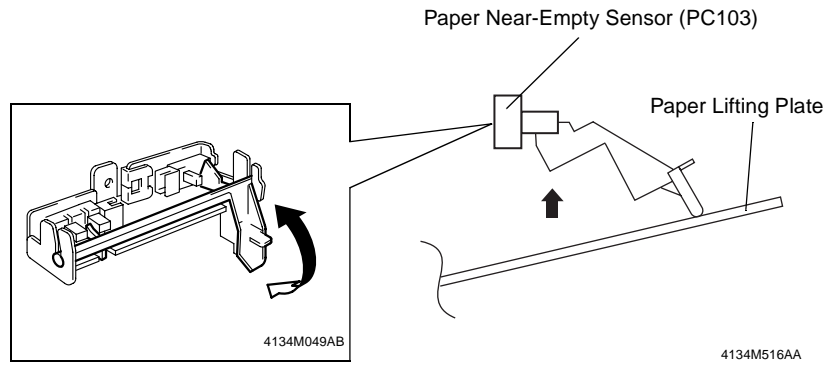

(4) Paper Empty Detection

- The paper empty condition is detected by the Paper Empty Sensor.

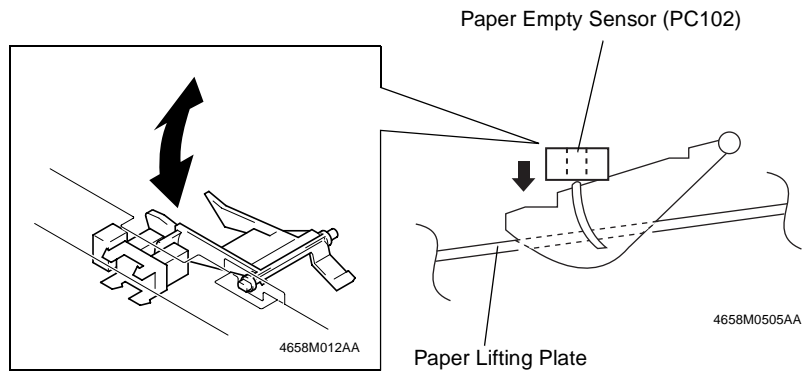

(5) Paper Take-Up Mechanism

- The Paper Take-Up Roller Motor drives the Paper Take-Up Roller via the Paper Take-Up Clutch.

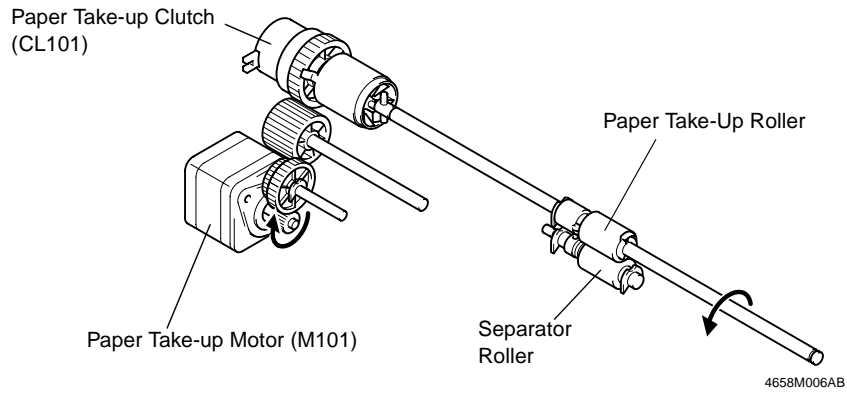

(6) Vertical Transport Mechanism

- The Paper Take-Up Motor provides the drive for the Vertical Transport Roller.

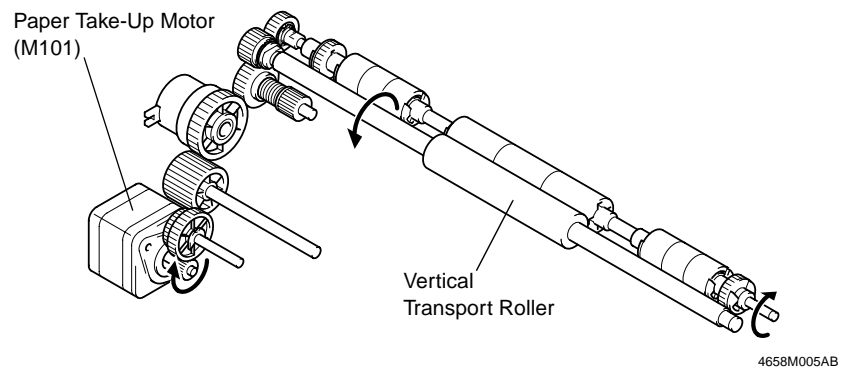

(7) Edge Guides and Trailing Edge Stop

- The Trailing Edge Stop can be removed and reinstalled to the specified position corresponding to the size of the paper to be loaded.
- The Edge Guides can be slid to the exact size of the paper to be loaded.

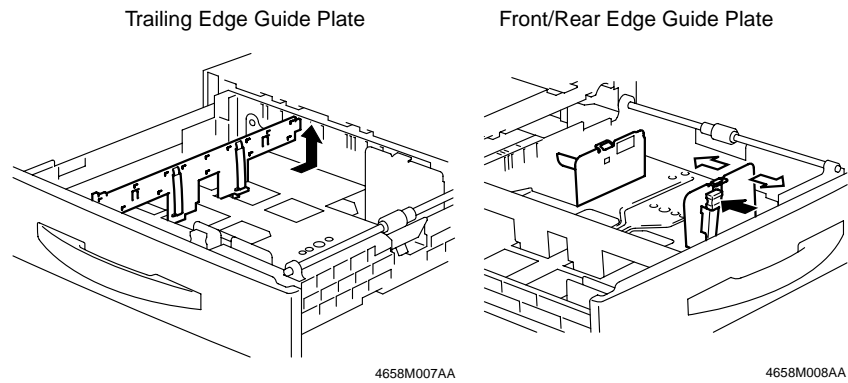

(8) Paper Lifting Plate

- The Paper Lifting Plate is locked in position when it is pressed down. It is unlocked when the drawer is slid into the unit.
- The Paper Lifting Plate is pushed upward by the Paper Lifting Springs at all times.

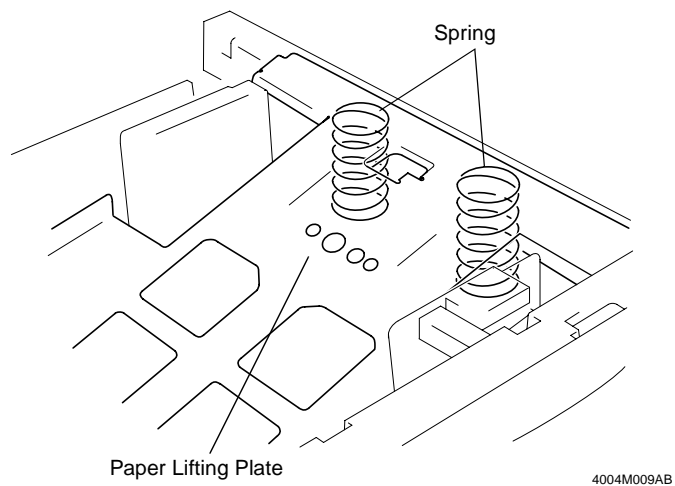

9-3. Manual Feed Tray (Optional)

- Paper can be fed manually one sheet at a time.
- The Manual Feed Paper Take-Up Drive Motor provides the drive for the Manual Feed Drive Roller.

(1) Manual Feed Paper Take-Up Mechanism

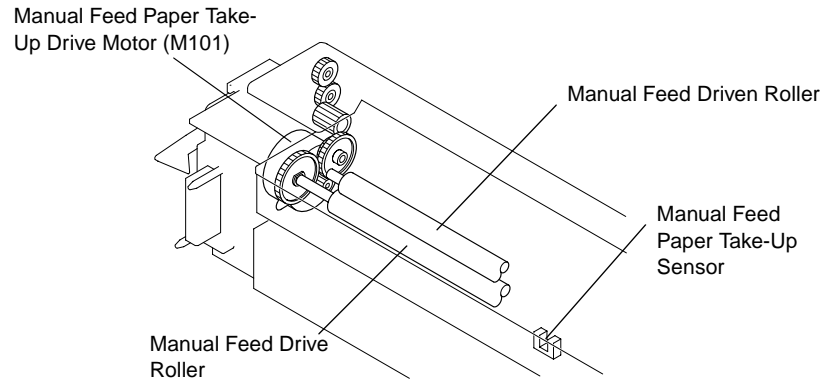

(2) Manual feed operation

- When paper is set, the sensor on Manual Feed Detecting Board is turned on.
- The Manual Feed Motor rotates, transports paper 15 mm, and goes into Standby mode.
- Paper is supplied to the main unit from the print request issued by the Controller.

10. TRANSPORT SECTION

- The Synchronizing Rollers synchronizes the image transfer function (2nd Image Transfer) with paper transport.

10-1. Synchronizing Roller Drive

- The Synchronizing Roller provides the drive for the Transport Drive Motor.

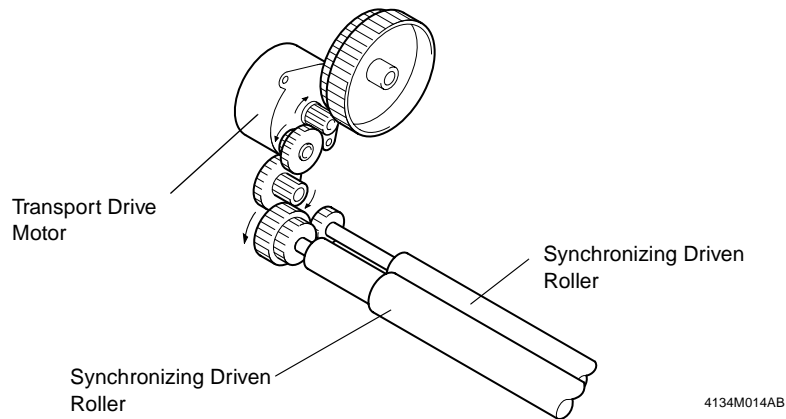

10-2. Image Transfer Failure Prevention During High Humidity

- When humidity is high and the paper in the printer gets damp, the charge from the image transfer charger passes through the paper and the Synchronizing Roller, drops into the frame ground, and Image Transfer Failure (low density image) occurs.
- A High Resistance Board is placed between the Synchronizing Driven Roller and the frame ground to prevent the flow of image transfer voltage.

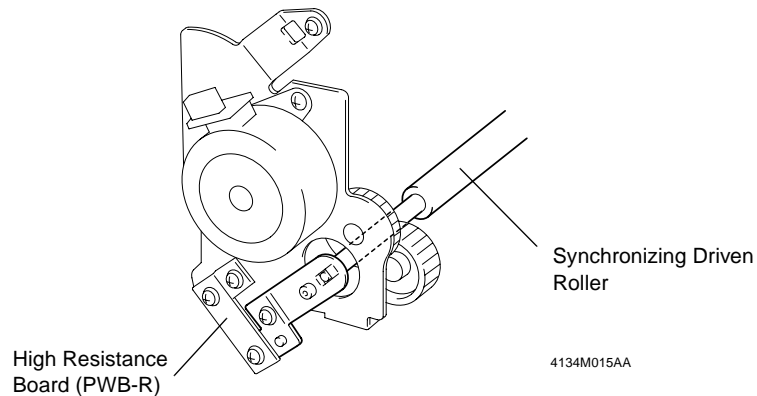

10-3. Switch of system speed

- The system speed is switched according to the type of paper.

Paper Type	System speed
Plain Paper	90 mm/s
Thick paper, OHP, envelopes, postcards, labels	45 mm/s

10-4. OHP Detecting

- OHP Detecting is performed by the OHP Detecting Sensor.
- Determines whether the paper type set and the OHP detection result match. It becomes a media error when they do not match.
- When a media error is detected, printing does not occur and the paper is fed out of the printer.

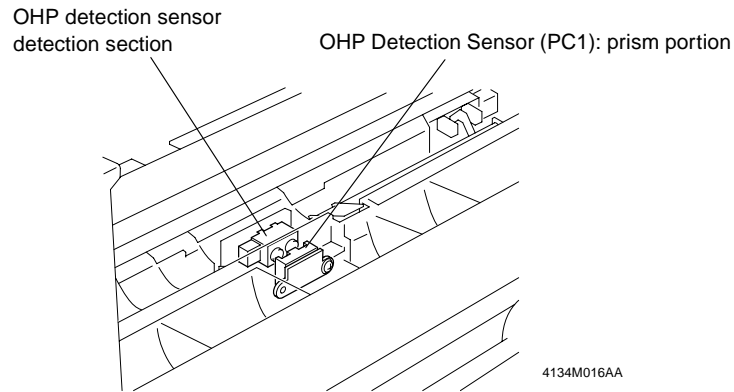

11. DUPLEX UNIT (OPTIONAL)

11-1. Drive of Duplex Unit

- The paper has a printed image on one side is temporarily fed toward the Exit Tray and, as soon as the trailing edge of the paper moves past the guide plate in front of the Exit Roller, the Exit Roller is turned backward so that the paper is fed into the Duplex Unit.
- Drive for the Exit Roller is disconnected from the printer when the Duplex Unit is mounted on the machine and, instead, it is provided by the Duplex Unit Turnover Motor of the Duplex Unit.
- The Transport Rollers of the Duplex Unit are driven by the Manual Bypass Paper Take-Up Drive Motor.
- The paper is transported to the printer by the Transport Rollers.

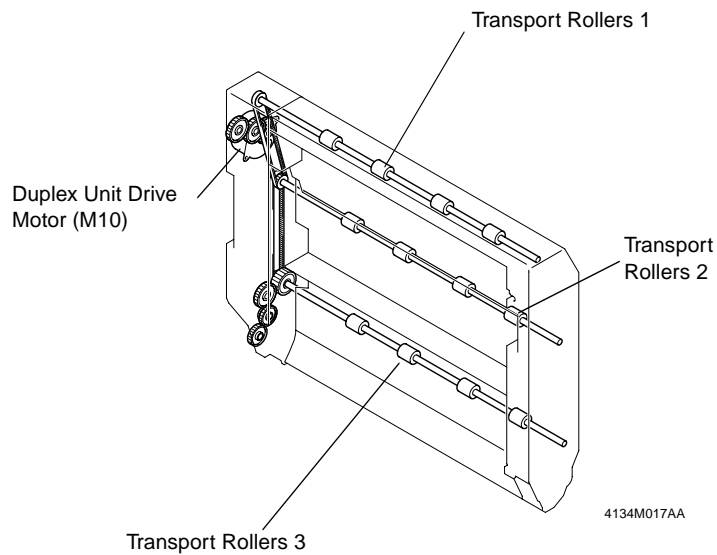

11-2. Paper Feeding System

(1) Operations in 2-sided printing with a single sheet of paper resident in, and circulated through, the system

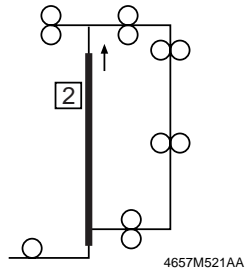

1. Paper is taken up and fed in and the image on page 2 of the original is printed.

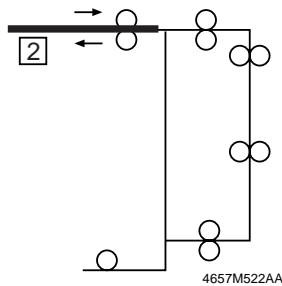

2. Paper is first transported to the exit portion and the paper is then switched back.

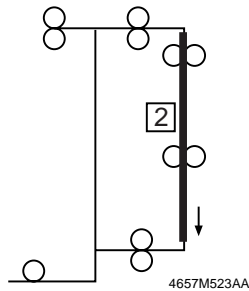

3. The 1-sided copy moves through the Duplex Unit and is directly subject to the second copy cycle without stopping.

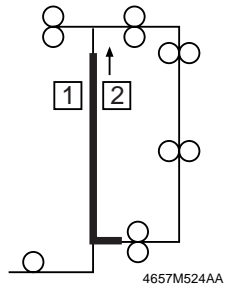

4. The image on page 1 of the original is printed on the paper that is taken up from the Duplex Unit.

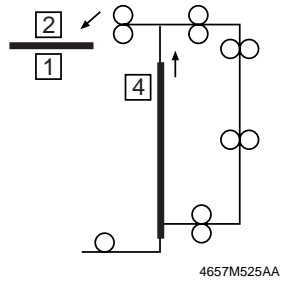

5. The first page is fed out of the printer.

* Steps from (2) to (5) are then repeated.

- (2) **Operations for 2-sided printing with two sheets of paper resident in the system, and with a new sheet of paper taken up when a printed page with images printed on both sides is fed out.**

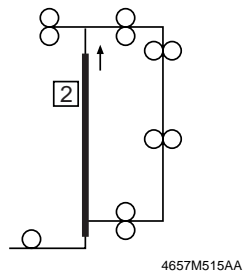

1. The first sheet of paper is taken up and fed in and the image on page 2 of the original is printed.

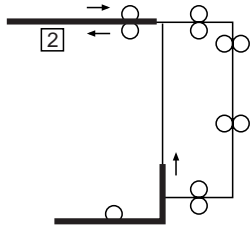

4657M516AA

2. The paper is switched back in the paper exit section.
3. At the same time, the 2nd sheet of paper is taken up and fed in.

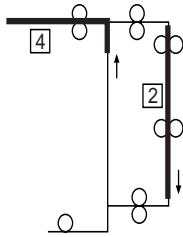

4657M517AA

4. The image on page 4 of the original is printed on the 2nd sheet of paper.
5. The 1st sheet of paper moves through the Duplex Unit and is directly subject to the second copy cycle without stopping.

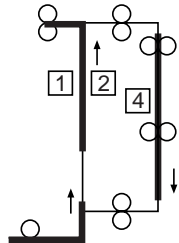

4330M501AA

6. The image on page 1 of the original is printed on the 1st sheet of paper that is re-fed.
7. The second sheet of paper is switched back and fed into the duplex unit.
8. At the same time, the 3rd sheet of paper is taken up and fed in.

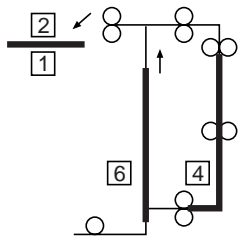

4330M502AA

9. At the same time, the 1st sheet of paper is fed out of the machine, the image on page 6 is printed on the 3rd sheet of paper.
10. The 2nd sheet of paper stops in the Duplex Unit.

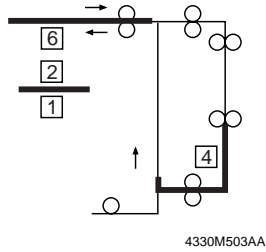

11. The 3rd sheet of paper is switched back in the paper exit area.
12. At the same time, the 2nd sheet of paper is directly subject to the second copy cycle.

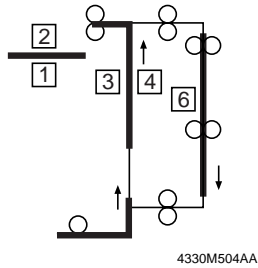

13. The image on page 3 of the original is printed on the 2nd sheet of paper.
14. The 3rd sheet of paper is stopped in the Duplex Unit.
15. At the same time, the 4th sheet of paper is taken up and fed in.

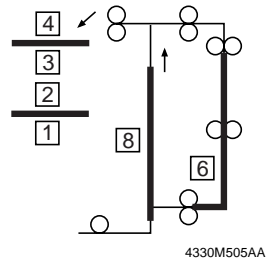

16. At the same time, the 2nd sheet of paper is fed out of the machine, the image on page 8 is printed on the 4th sheet of paper.
17. The 3rd sheet of paper stops in the Duplex Unit.

MAINTENANCE



1. MAINTENANCE SCHEDULE LIST

- To ensure that the printer produces good copies and to extend its service life, it is recommended that the maintenance tasks described in this schedule be carried out as instructed.

	PM Parts	Cycle (K=1,000)		Near-Life De-tection	Life De-tection	Life Stop	Reference Page in the Manual
		Clean.	Re-place				
Paper Take-Up Section	Paper Take-Up Roll	When paper take-up failure occurs	200K	×	×	×	☞ E-5
	Separator Roll	When paper take-up failure occurs	200K	×	×	×	☞ E-67
	Vertical Transport Roller	When vertical transport failure occurs	—	×	×	×	☞ E-7
	Vertical Transport Roller	When transport failure occurs	—	×	×	×	☞ E-7
	Paper Feed Roll (optional)	When paper take-up failure occurs	200K	×	×	×	☞ E-5
	Separator Roll (optional)	When paper take-up failure occurs	200K	×	×	×	☞ E-67
	Vertical Transport Roller (optional)	When transport failure occurs	—	×	×	×	☞ E-7
	Vertical Transport Roller (optional)	When transport failure occurs	—	×	×	×	☞ E-7
Image Transfer Section	Transfer Belt Unit	—	85K	○	○	×	☞ E-22
	Waste Toner Box	—	3.5K	○	○	○	☞ E-8
Developing Section	Print Unit	—	15.9K	○	○	○	☞ E-10
	Toner Cartridge Black color	—	6K	○	○	○	☞ E-16
			5.5	○	○	○	
Ozone Filter	—	85K	×	×	×	☞ E-9	

Fusing Section	Fuser Unit	—	120K	○	○	×	☞ E-19
----------------	------------	---	------	---	---	---	--------

○: Perform ×: No not perform

NOTE

- Replace the Paper Take-Up Roll and Separator Roll at the same time.
- Replace the Transfer Belt Unit, Ozone Filter at the same time.
- Replace the Print Unit and Toner Cartridge at the same time.
- The numeric values in the Maintenance Cycle column represent the Life Counter values.
- The above Maintenance Schedule is subject to change without notice.

1-1. Guidelines for Life-time Expected Values by Unit

- The life-time expected values represent the number of copies or equivalent values for the given condition (see the tables below). Actual values may vary depending on the printer operating conditions.

Print Conditions	
Print Method	3 Copies per print job
Paper Size	A4C
Print Ratio	Each color 5%

(1) Guideline for Near-Life values

Unit name	Near-Life value	Detection contents
Print Unit	14.3K	The number of copies, or hours of Print Unit Drive Motor operation, whichever Near-Life value is reached first. (*)
Toner cartridge	Black 5.55K Color 5.05K	Provides feedback concerning consumption based on the amount of toner remaining. Detects toner near-empty condition.
Waste Toner Box	3K	The waste toner full detection sensor detects the waste toner near-full condition.
Fuser Unit	115K	The number of copies, or the hours of Fusing Drive Motor operation, whichever Near-Life value is reached first. (*)
Transfer Belt Unit	81.4K	The number of copies, or the hours of Print Unit Drive Motor Bk operation, whichever Near-Life value is reached first. (*)

(2) Guidelines for life value

Unit name	Life value	Detection	Life reset
Print Unit	Minimum setting 15.9K Maximum setting 19.5K	<ul style="list-style-type: none"> The number of copies, or the hours of Print Unit Drive Motor operation, whichever Life value (maximum setting) is reached first. Detects "toner empty" between the minimum and maximum settings. After the number of copies or hours of Print Unit Drive Motor operation, whichever Life value (minimum setting) is reached first, detection occurs by observing the toner empty signal. (*) 	Reset automatically when a new part is detected.
Toner Cartridge	Black 6K Color 5.5K	<ul style="list-style-type: none"> The toner level is detected, toner consumption is calculated, and toner empty is detected. When the print unit reaches its life value, the life value is displayed instead of toner empty. 	Reset automatically when a new part is detected.
Waste Toner Box	3.5K	After waste toner near-full is detected, waste toner full is detected after approximately 0.5K prints.	Waste Toner Box Reset when replaced.

Fuser Unit	120K	The number of copies, or hours of Fusing Drive Motor operation, whichever Life value is reached first. (*)	Resets automatically when a new part is detected.
Transfer Belt Unit	85K	The number of copies, or hours of Print Unit Dive Motor Bk operation, whichever Life value is reached first. (*)	Resets automatically at detection of a new part.

* Paper that is longer than Letter C but shorter than Ledger is counted as 2 pages and paper that is longer than Ledger is counted as 3 pages.

2. DISASSEMBLY/REASSEMBLY AND CLEANING

(1) Cleaning the Paper Take-Up Roll

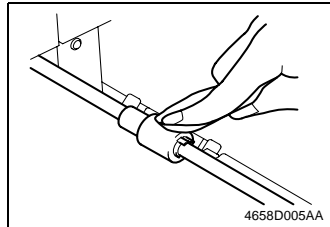

1. Slide out the drawer.
2. Using a dry cloth, wipe the Paper Take-Up Roll clean of any dirt.

(2) Replacing the Paper Take-Up Roll

<1st Drawer>

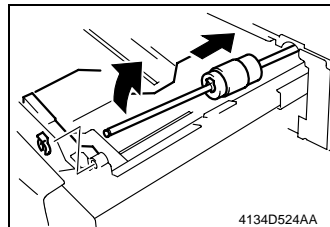

1. Slide out the drawer.
2. Lock the Paper Lifting Plate into position.
3. Snap off one C-clip from the Paper Take-Up Roll Shaft.
4. Slide the shaft to the rear and take the shaft off the front bushing.

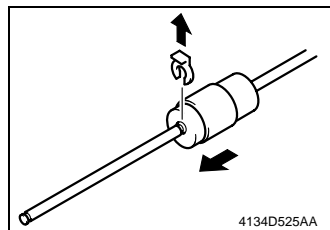

5. Snap off one C-clip and remove the collar and Paper Take-Up Roll.

<The 2nd Drawer and the Paper Take-up Unit (optional) >

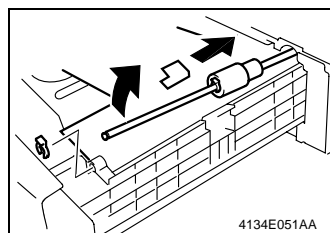

1. Slide out the drawer.
2. Lock the Paper Lifting Plate into position.
3. Snap off one C-clip from the Paper Take-Up Roll Shaft.
4. Slide the shaft to the rear and take the shaft off the front bushing.

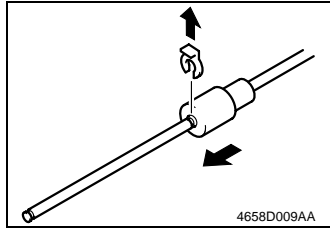

5. Snap off one C-clip and remove the Paper Take-Up Roll.

(3) Cleaning the Paper Separator Roll

<1st Drawer>

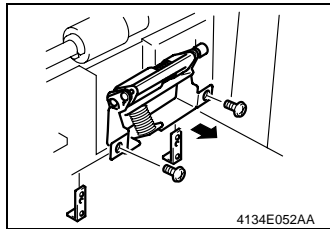

1. Slide out the drawer.
2. Remove two screws and the Paper Separator Roll mounting bracket assembly.

NOTE

- Hold the reinforcement plate with your hand as it may come off when the screws are removed.
- When reinstalling the reinforcement plate, make sure that it is dowelled into position.

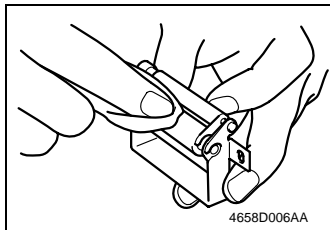

3. Using a dry cloth, wipe the Paper Separator Roll clean of dirt.

<The 2nd Drawer and the Paper Take-up Unit (optional) >

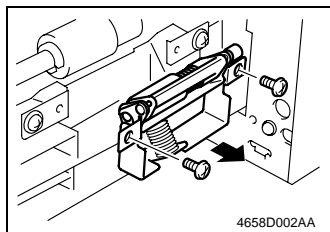

1. Slide out the drawer.
2. Remove two screws and the Paper Separator Roll mounting bracket assembly.

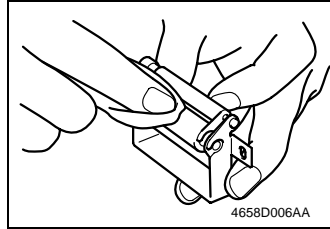

3. Using a dry cloth, wipe the Paper Separator Roll clean of dirt.

(4) Replacing of the Separator Roll Assembly

<1st Drawer>

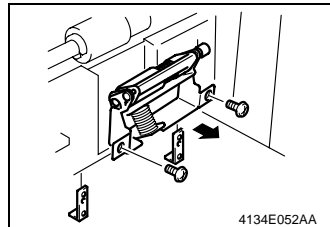

1. Slide out the drawer.
2. Remove two screws and the Paper Separator Roll mounting bracket assembly.

NOTE

- Hold the reinforcement plate with your hand as it may come off when the screws are removed.
- When reinstalling the reinforcement plate, make sure that it is dowelled into position.

<The 2nd drawer and the Paper Take-up Unit (optional) >

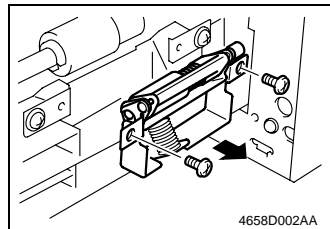

1. Slide out the drawer.
2. Remove two screws and the Paper Separator Roll mounting bracket assembly.

(5) Cleaning the Vertical Transport Roller/Roll

<The 2nd Drawer and the Paper Take-up Unit (optional) >

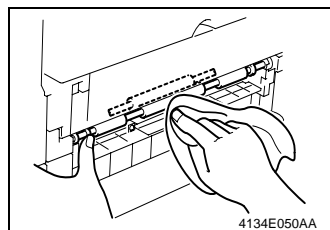

1. Slide out the drawer.
2. Open the Right Door.
3. Using a dry cloth, wipe the vertical transport roller/roll clean from dirt while turning the knob.

(6) Replacing the Waste Toner Box

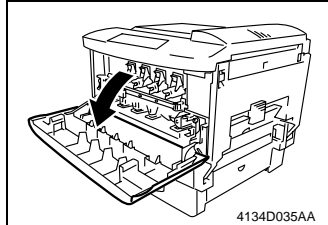

1. Turn off the Power Switch.
2. Open the Front Door.

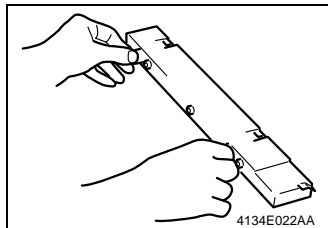

3. Remove the waste toner box cover from the box.

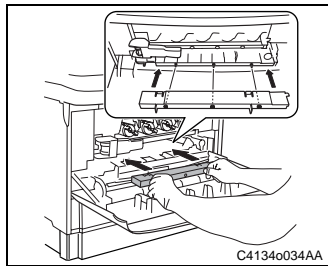

4. Grasp the handle on the box cover and attach it to the top of the Waste Toner Box.

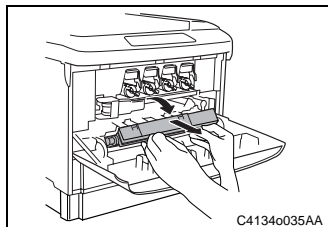

5. Grasp the handle on the box cover, tilt it toward you and remove the waste toner box.

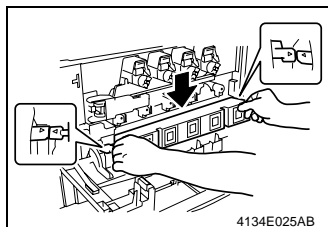

6. Place the new waste toner box on the Front Door with the arrow mark on the Waste Toner Box aligned with the arrow mark on the inside of the Front Door.
7. Close the Front Door.
8. Turn on the Power Switch.

(7) Replacing the Ozone Filter

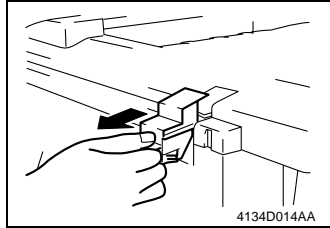

1. Remove the Ozone Filter Cover.

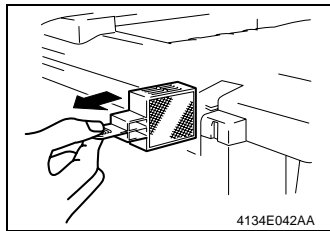

2. Remove the Ozone Filter.

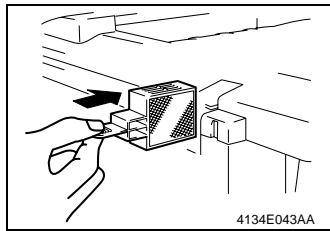

3. Unwrap the new ozone filter, and install it.

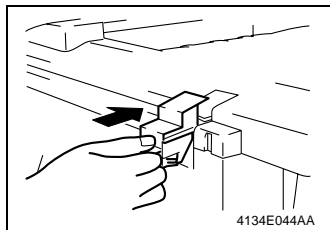

4. Reinstall the ozone filter cover.



3. REPLACING THE UNITS

(1) Replacing the Print Unit

<Removal Procedure>

NOTE

- When replacing the Print Unit, be sure to leave the toner cartridge installed in the print unit to avoid spilling toner powder.
-

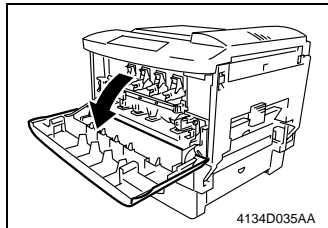

1. Turn off the Power Switch.

NOTE

- Always make sure to turn the printer off before turning the power switch off.
-

2. Open the Front Door.

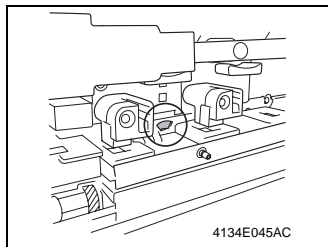

3. Check that the window on the Transfer Belt Unit. If the indicator is red, a paper misfeed occurred within the printer or the printer has been turned off while operating. Remove the misfed paper, close the Front Door, and then turn on the Power Switch. After warming up is completed, turn off the Power Switch.

NOTE

- Removing the Print Unit when the indicator is red may damage the Image Transfer Belt.
-

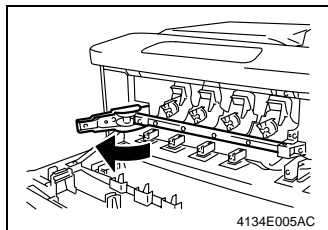

4. Grasp the handle on the Print Unit Support Bar, release the lock, and pull the bar forward.

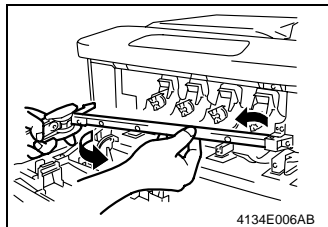

5. Grasp the Print Unit Support Bar with both hands to remove it.

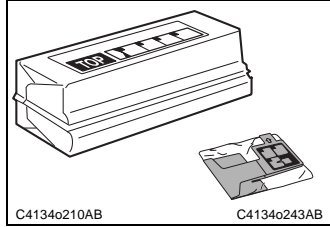

6. Remove the new Print Unit, which is wrapped in an aluminum pack, and the Print Unit Disposal Bag from the box

NOTE

- Check that "Operating Procedure" appears on the front of the aluminum pack.

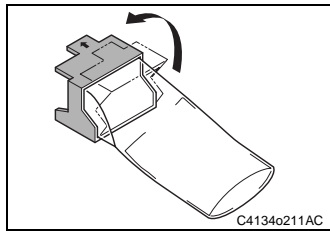

7. Open the square opening in the Print Unit Disposal Bag.

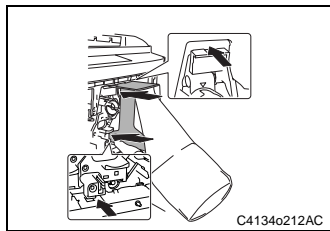

8. While supporting the opening from the bottom with your left hand, insert the end of the opening into the print unit compartment. Then, push the opening into the printer.

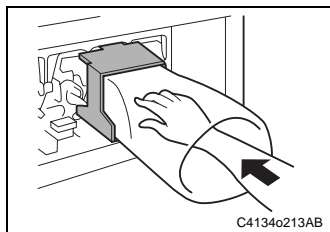

9. Insert your right hand into the Print Unit Disposal Bag.

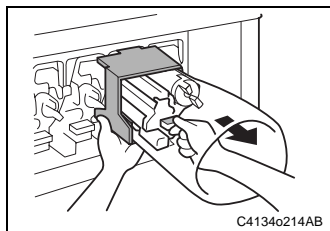

10. Use your right hand to grab the knob on the Print Unit, and then slowly pull the Print Unit out as far as possible.



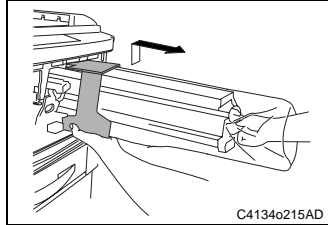

11. Lift up the Print Unit a little.

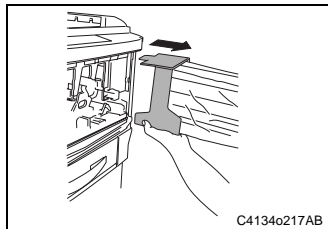

12. Pull your right hand out about 50 mm to move the Print Unit into the disposal bag.

13. Pull out the Print Unit together with its disposal bag.

NOTE

- While pulling out the Print Unit, do not allow toner to spill. Firmly grab the Print Unit so that it does not fall.
-

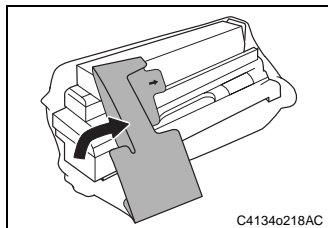

14. Fold over the opening of the Print Unit Disposal Bag while making sure that toner does not spill.

15. When placing the used print unit, which has been removed, on a desk, for example, place it on old newspaper and position it.

<Reinstallation Procedure>

NOTE

- Since the Imaging Unit is highly susceptible to light, keep it in its aluminum packaging until immediately prior to installation. After removing the Print Unit from the aluminum packaging, install it into the printer as soon as possible to avoid exposure to light.
- When replacing the Print Unit, be sure to replace the toner cartridge at the same time.

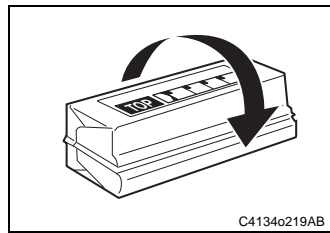

1. Hold the left and right ends of the new print unit, wrapped in the aluminum pack, and then turn the Print Unit over toward you.

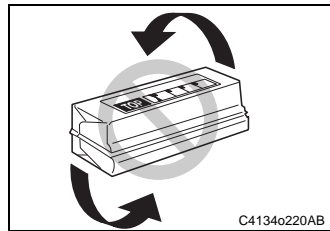

NOTE

- Do not turn the Print Unit over the left or right, otherwise toner will spill out of the Print Unit.

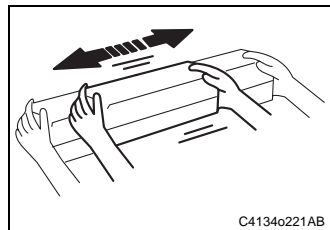

2. Lightly shake the Print Unit five or six times to the left and right.

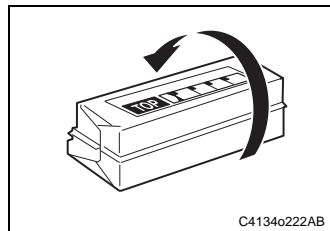

3. Turn the Print Unit away from you and turn it over.

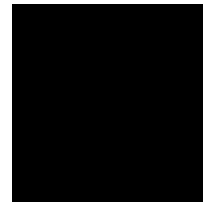

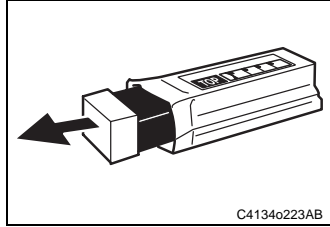

4. Open the aluminum pack, and then remove the Print Unit from the pack.

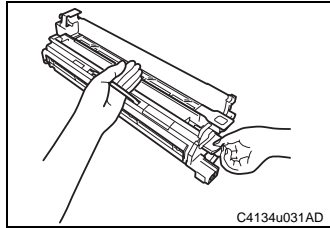

NOTE

- Hold the handle and knob on the Print Unit, as shown below.
- Do not remove the protective tapes (2 locations) until ready to install it into the main unit.

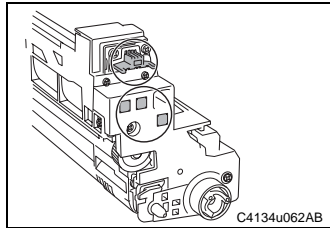

NOTE

- Never touch the Print Unit terminal.

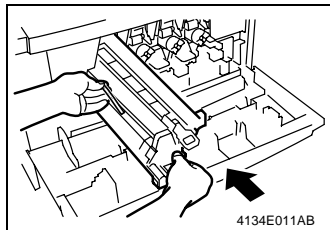

5. Match the color labels (Y • M • C • K) to the labels at the installation points on the main unit and insert.

NOTE

- Do not insert a print unit that has different colored labels than the labels on the main unit.

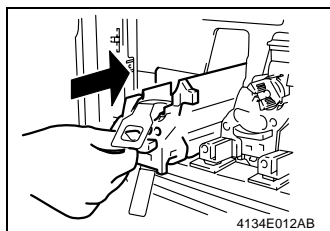

6. Grasp the knob on the print unit and gently insert until it is firmly seated.

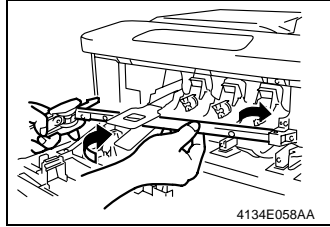

7. Reinstall the Print Unit Support Bar.

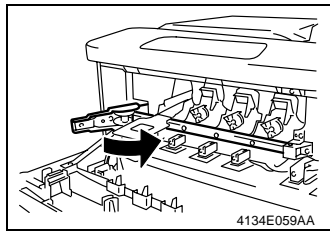

8. Close the Print Unit Support Lever and lock into place.

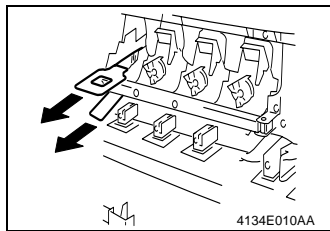

9. Remove the protective tapes(2).

10. Install the toner cartridge.

☞ E-16[(2) Replacing the toner cartridge]

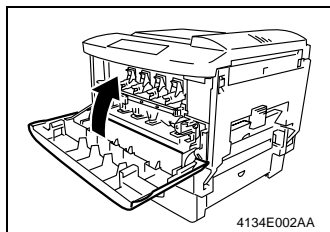

11. Close the Front Door.

12. Turn on the Power Switch.



(2) Replacing the Toner Cartridge

<Removal Procedure>

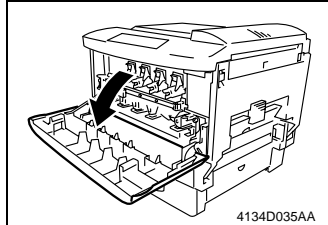

1. Turn off the Power Switch.

NOTE

- Always make sure to turn the printer off before turning the power switch off.
-

2. Open the Front Door.

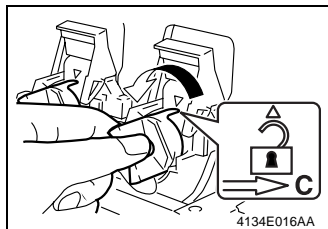

3. Turn the knob on the replacement toner cartridge to the left (counter clockwise) until it is in a horizontal position.

NOTE

- Ensure that the window near the knob displays the lock release mark.
-

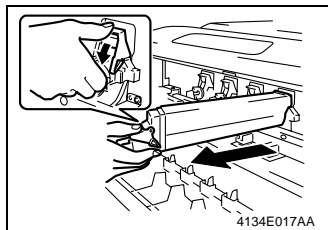

4. Pull the lever down and slide out the toner cartridge approximately 15 cm.

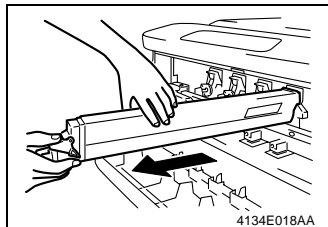

5. Grasp the top of the toner cartridge with your left hand and remove it.

<Reinstallation Procedure>

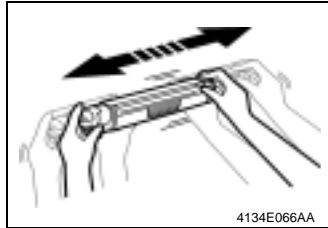

1. To loosen the toner inside the Toner Cartridge, vigorously shake the Toner Cartridge horizontally 10 or more times.

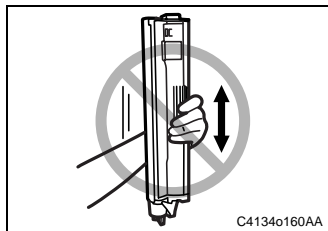

NOTE

- Do not shake the Toner Cartridge vertically.
- Be careful not to hold the Toner Cartridge by its shutter.

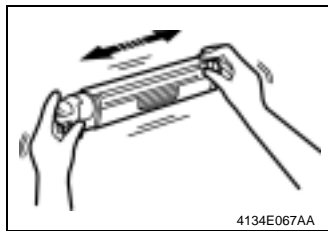

2. Next, to distribute the toner evenly inside the Toner Cartridge, gently shake the Toner Cartridge horizontally a few more times.

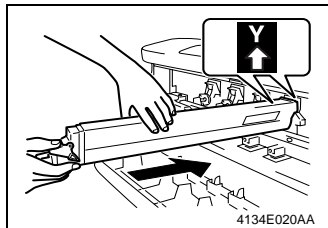

3. Match the color label on the main unit (on the rack side) to the toner cartridge color, and insert into position.

NOTE

- Check the arrows on the front end of the toner cartridge to insert it in the proper direction.
- A toner cartridge that is a different color than the color of the label on the rack cannot be inserted. Be sure to insert the toner cartridge with the proper label color.

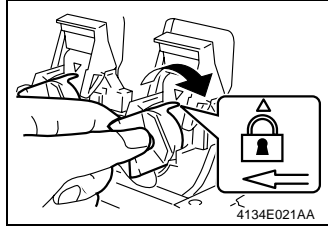

4. Turn the knob on the toner cartridge to the right (clockwise).

NOTE

- Ensure that the window near the knob displays the lock mark.
- Be sure to turn the knob to the correct position to ensure that the front door closes properly.

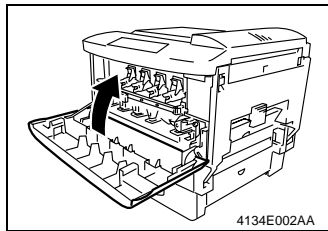

5. Close the Front Door.
6. Turn on the Power Switch.

(3) Replacing the Fuser Unit

<Removal Procedure>

NOTE

- Before replacing the Fuser Unit, ensure that it is not hot.
-

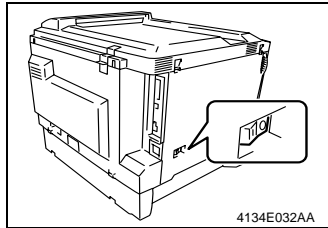

1. Turn off the Power Switch, and then wait for about 20 minutes.

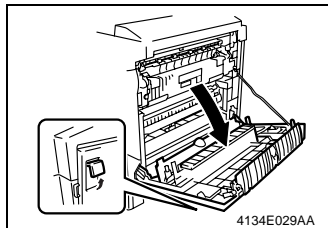

2. Pull the release lever on the Right Door to open it.

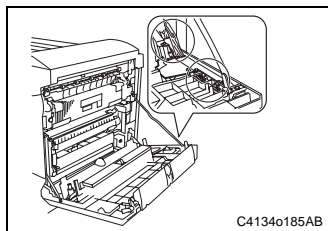

NOTE

- Take care not to come in contact with the connector or harness located inside the right door, as this may cause electrostatic destruction to the electric components inside the printer.
-

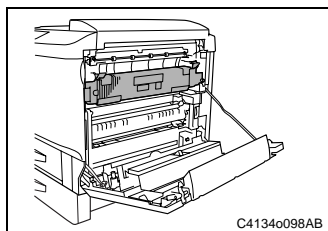

NOTE

- When handling the Fuser Unit, take care not to touch the peripheral components as they are very hot.
-

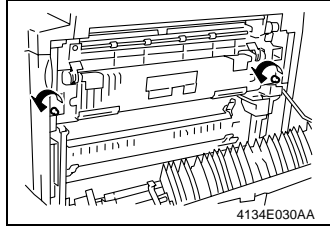

3. Loosen the two screws.

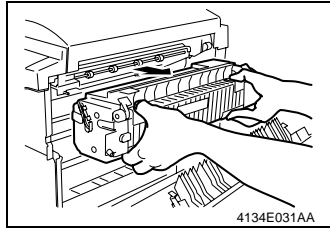

4. Remove the Fuser Unit.

<Reinstallation Procedure>

NOTE

- Keep the shipping brackets that the new Fuser Unit comes with for later use when moving or transporting the printer.

1. Remove the Fuser Unit from its packaging.

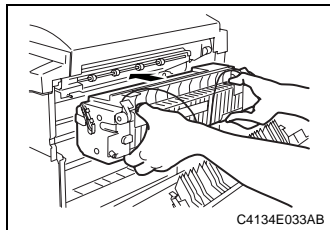

2. Insert the Fuser Unit firmly into position.

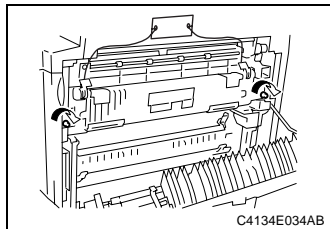

3. Tighten the two screws.

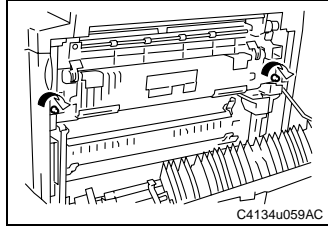

4. Lower the two Fusing Misfeed Clearing Levers, and then remove the shipping brackets.
5. Return the levers to their original position.

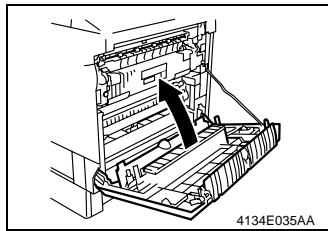

6. Close the Right Door.
7. Turn on the Power Switch.

<Other Information>

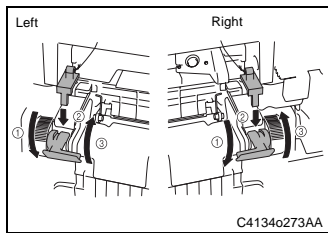

- If the printer is not used (is not turned on) for more than two weeks, lower the levers, and then attach the shipping brackets to the Fuser Unit. Return the levers to their original positions.

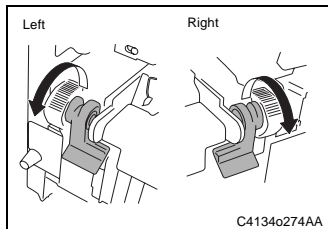

- If the shipping brackets were lost, lower the levers to their lowest positions. Before using the printer again, return the levers to their original positions.

NOTE

- If the printer is used without the levers returned to their original positions, decrease image fusing may result.

(4) Replacing the Transfer Belt Unit

<Removal Procedure>

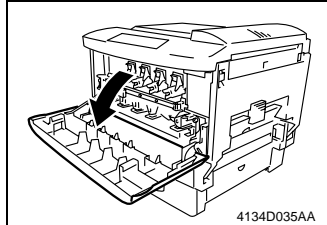

1. Turn off the Power Switch.

NOTE

- Always make sure to turn the printer off before turning the Power Switch off.
-

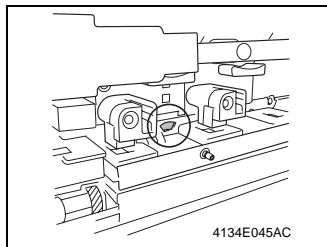

2. Open the Front Door.
3. Place an old newspaper over the Front Door in case any toner spills.

4. Check that the window on the Transfer Belt Unit. If the indicator is red, a paper misfeed occurred within the printer or the printer has been turned off while operating. Remove the misfed paper, close the Front Door, and turn on the Power Switch. After warming up is completed, turn off the Power Switch.

NOTE

- Removing the Print Unit when the indicator is red may damage the Image Transfer Belt.
-

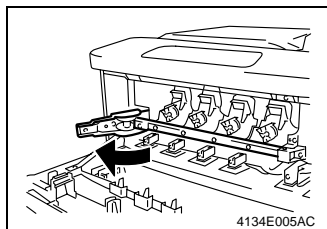

5. Grasp the handle on the Print Unit Support Bar, release the lock, and pull the bar forward.

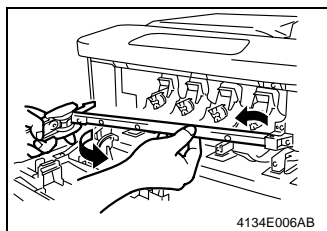

6. Grasp the Print Unit Support Bar with both hands to remove it.

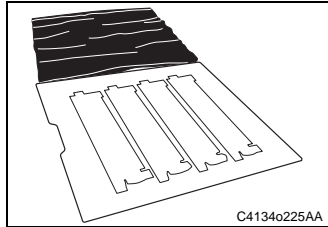

7. Remove the print unit platform from the box for the Transfer Belt Unit.
8. Place the Print Unit Platform near the printer.

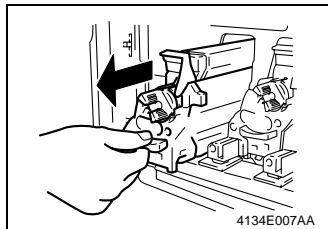

9. Remove all the colors (4) in the Print Unit.

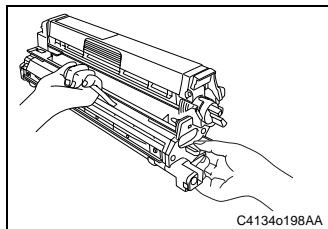

NOTE

- Hold the handle and knob on the Print Unit, as shown below.
-

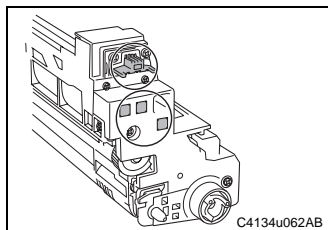

NOTE

- Take care not to come into contact with the Print Unit terminal, as this may cause electrostatic destruction to the electric components inside the Print Unit.
-

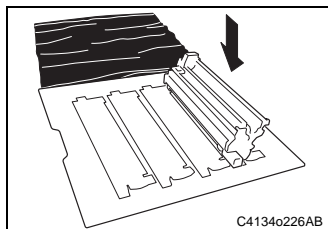

10. Place the removed print unit on the Print Unit Platform.

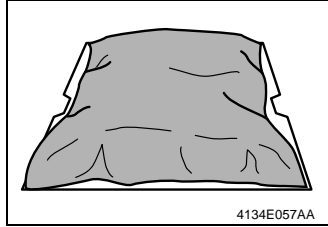

11. Place the shading sheet over the removed print unit.

NOTE

- Since the Print Unit is highly susceptible to light, cover it with the sheet as quickly as possible.

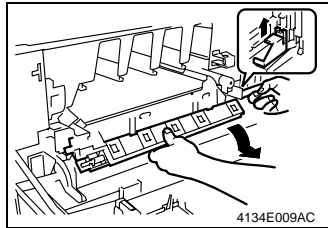

12. Lift up the slider on the right side of the cover, and then carefully tilt the Waste Toner Box toward you to remove it.

NOTE

- If scattered toner has accumulated around the waste toner box, clean the area before removing the box.
- Do not place the removed waste toner box on an unstable or slanting surface.

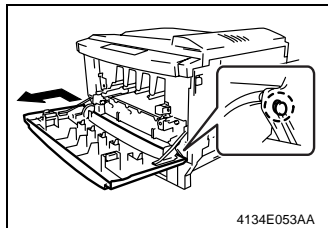

13. Remove the Front Door.
⇒ D-4[Disassembly/assembly (1) Remove the Front Door]

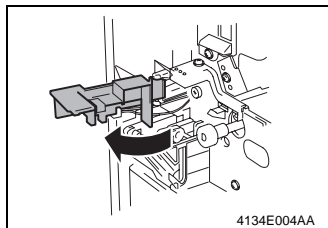

14. Open the cover.

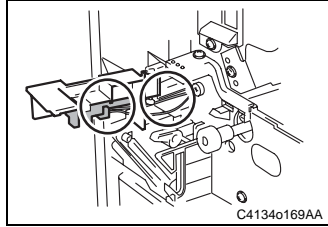

NOTE

- Take care not to come into contact with the sensor, connectors and wire harness located inside the cover, as this may cause electrostatic destruction to the electric components inside the printer.

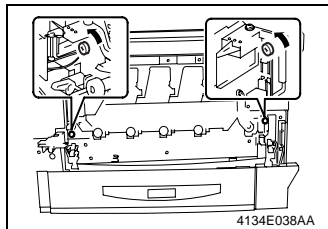

15. Remove the 2 right and left screws.

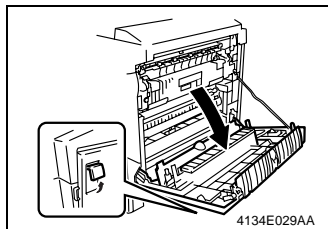

16. Pull the release lever on the Right Door to open it.

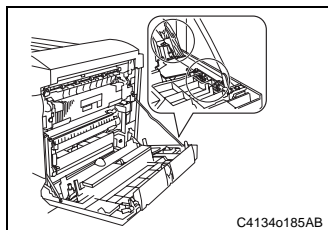

NOTE

- Take care not to come into contact with the connectors and harness located inside the right door, as this may cause electrostatic destruction to the electric components inside the printer.

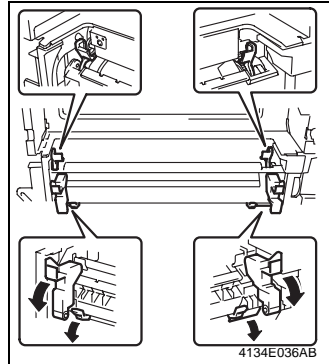

17. Release the green Synchronizing Roller lock lever (2 locations).
18. Release the black Secondary Image Transfer lock lever (2 locations) and the green Secondary Image Transfer lock lever (2 locations).

NOTE

- Be careful not to remove the Transfer Belt Unit without releasing the black Secondary Image Transfer lock lever (2 locations) as this will damage it.

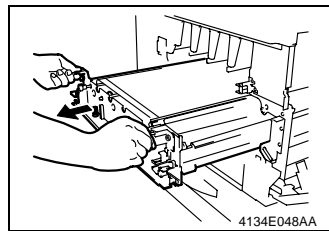

19. Hold the left and right knobs and slide out the Transfer Belt Unit approximately 25 cm.

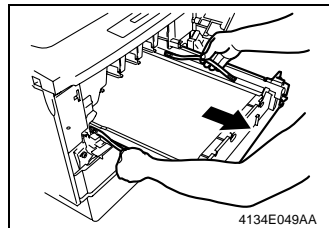

20. Grasp the handles (in two places) in the center of the Transfer Belt Unit and raise the unit slightly to remove it.

<Reinstallation Procedure>

NOTE

- When installing the Transfer Belt Unit, be careful not to get fingerprints on the Image Transfer Belt or Secondary Image Transfer Roller, as this may cause image quality problems.

1. Remove the Transfer Belt Unit from its packaging.

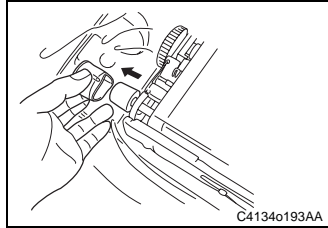

NOTE

- Remove the protective material from the drive coupling.

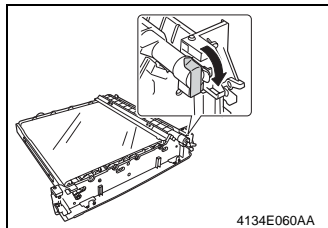

NOTE

- Be sure to remove the seal from the Waste Toner Transport portion.

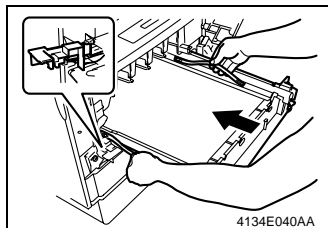

2. Insert the Transfer Belt Unit.

NOTE

- When inserting the Transfer Belt Unit, be careful not to interfere with the left cover.

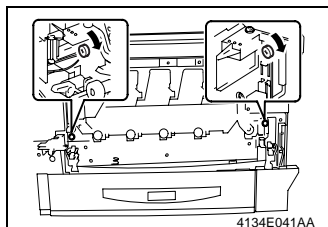

3. Tighten the 2 left and right screws.

NOTE

- When tightening the screws, always tighten the left screw first.

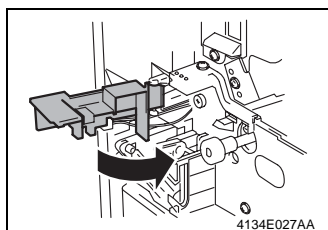

4. Close the cover.

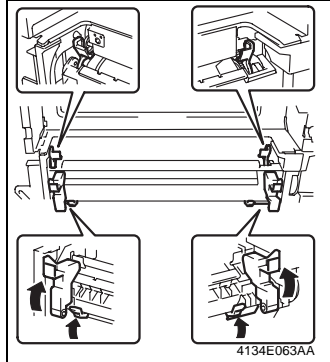

5. Close the green Synchronizing Roller lock lever (2 locations).
6. Close the black Secondary Image Transfer lock lever (2 locations) and the green Secondary Image Transfer lock lever (2 locations).

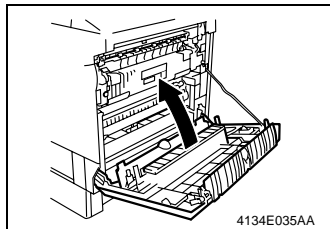

7. Close the Right Door.

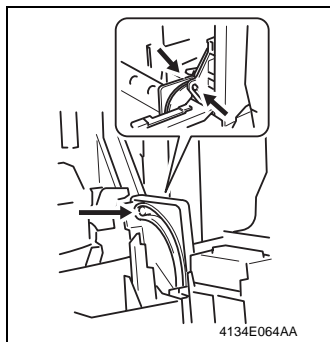

8. Set the fitting pin on the right side of the Front Door to the right hinge.

NOTE

- *Make sure that the hinge on the right side of the printer fits into the fitting pin on the right side of the Front Door.*
-

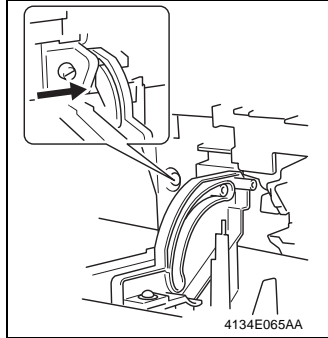

9. Set the fitting pin on the left side of the Front Door to the left hinge.
10. Move the hinge to the right, and then tighten the screw to secure the Front Door.

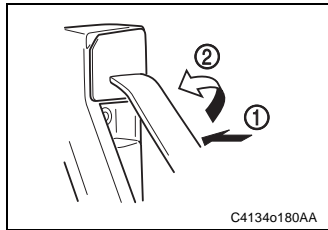

11. Attach the right Front Door stopper to the printer, and then rotate the stopper 90° to the left to secure it.

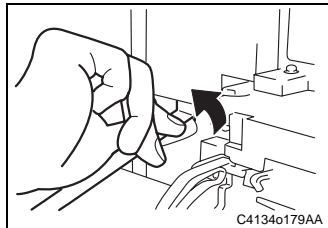

12. Attach the left Front Door stopper to the printer, and then rotate the stopper 90° to the left to secure it.

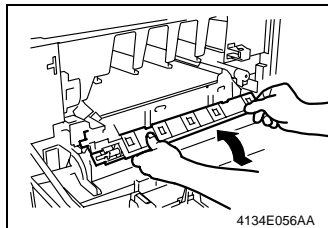

13. Reinstall the Waste Toner Box that was removed in removal procedure 9.

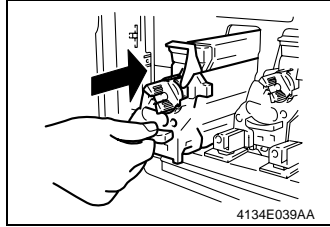

14. Reinstall the Print Unit that was removed in Removal Procedure 6.

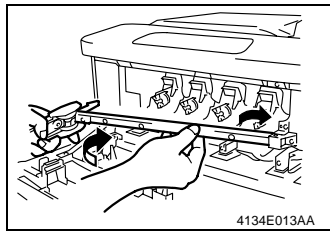

15. Reinstall the Print Unit Support Bar.

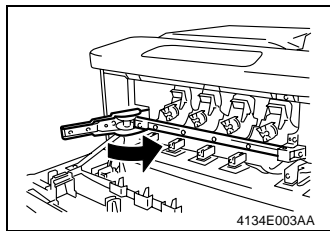

16. Close the Print Unit Support Lever and lock into place.

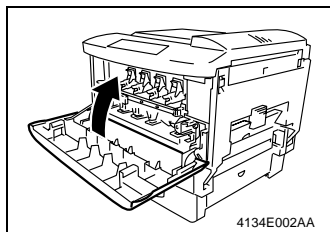

17. Close the Front Door.

18. Turn on the Power Switch.

ASSEMBLY/ DISASSEMBLY



1. SERVICE INSTRUCTIONS

1-1. Identification of Fuses

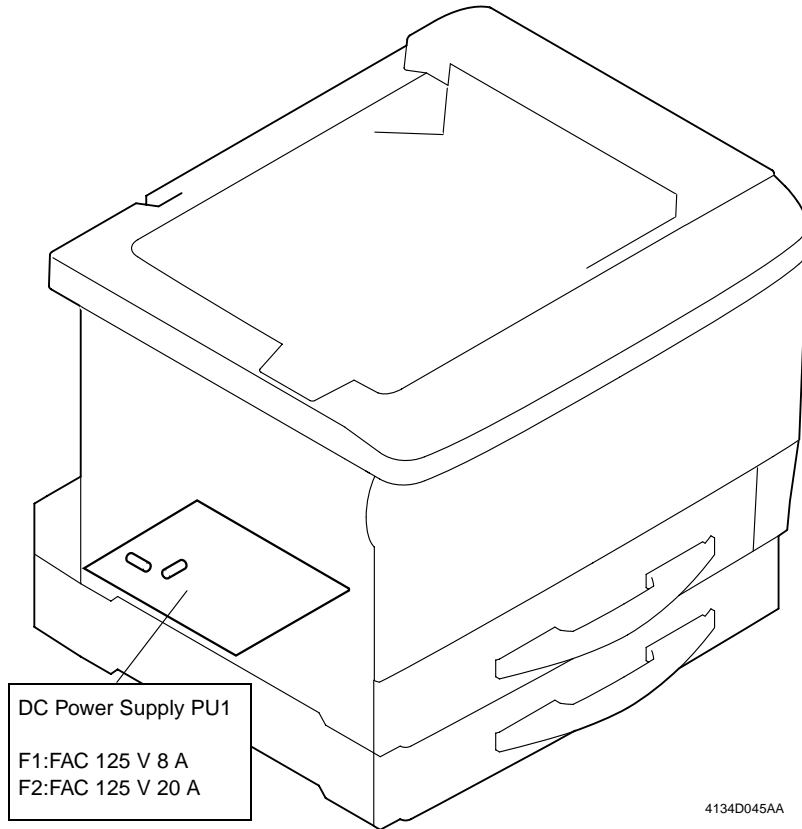

1-2. Parts Which Must Not Be Touched

(1) Screws that must not be removed

Purpose of red paint

- *Red paint is applied to parts which must not be adjusted, replaced or re-tightened.*
 - *Red-painted screws must not be removed or loosened. Note that when two or more screws are used on the part in question, only one representative screw might be marked with red paint.*
-

(2) Do not turn on the Variable Resistors on Board

Do not turn on the variable resistors on boards for which no adjusting instructions are given in ADJUSTMENT.

2. ASSEMBLY/DISASSEMBLY

2-1. Doors, Covers and Exterior Parts

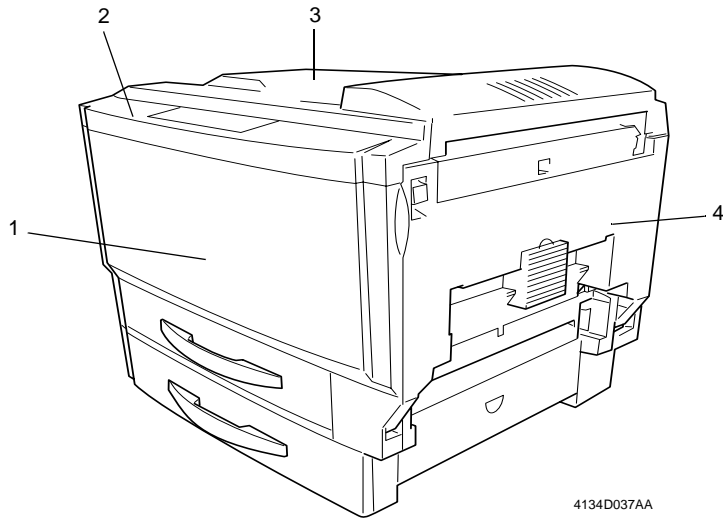

4134D037AA

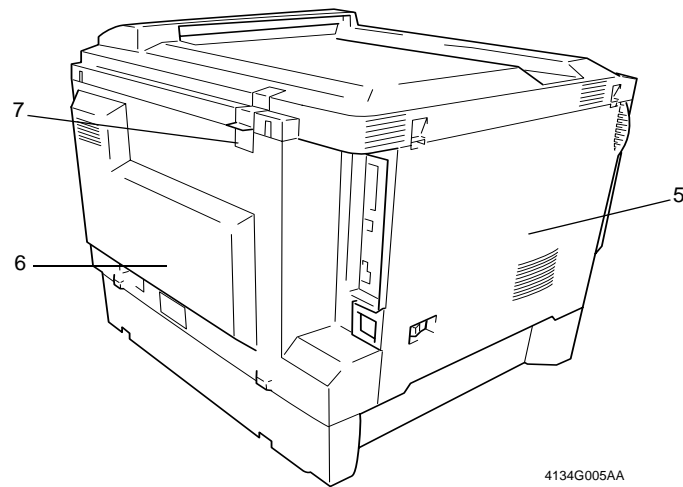

4134G005AA

- | | |
|----------------|-----------------------|
| 1. Front Door | 5. Left Cover |
| 2. Panel Cover | 6. Rear Cover |
| 3. Top Cover | 7. Ozone Filter Cover |
| 4. Right Door | |

2-2. Removing Doors, Covers and Exterior Parts

(1) Removing the Front Door

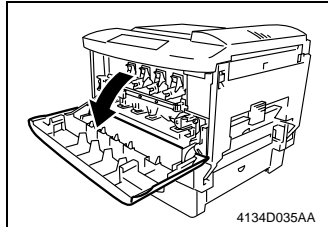

1. Open the Front Door.

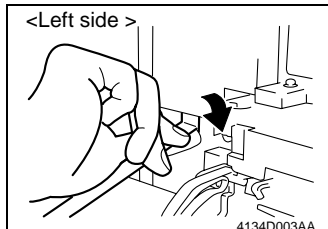

2. Turn the Front Door stoppers (two locations) to the right at 90° to remove.

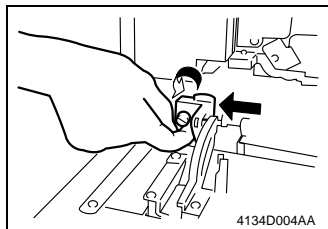
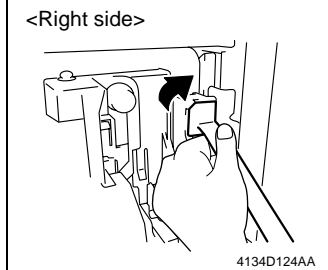

3. Loosen one screw and slide the hinge to the left.

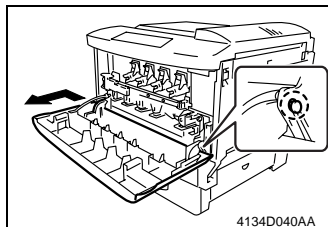

4. To remove the Front Door, slide it to the left.

NOTE

- When removing the Front Door, make sure that the positions of the hinges on the right side of the main unit and the boss on the right side of the Front Door are lined up correctly.
-

(2) Removing the Left Cover

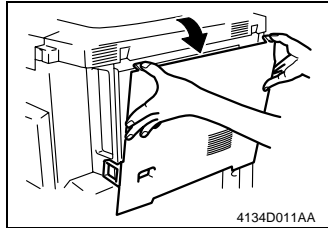

1. Press down on the levers (two locations) on the top of the Left Cover to remove it.

(3) Removing the Panel Cover

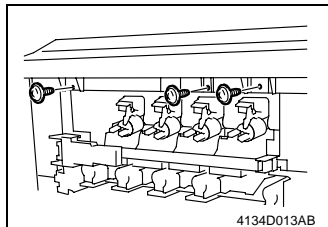

1. Open the Front Door and remove three screws.

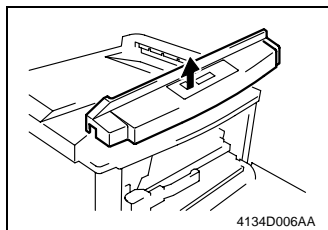

2. Pull the Panel Cover forward and out of its position, using care when handling the flat cable.

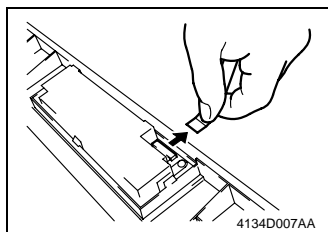

3. Detach the flat cable and remove the Panel Cover.



(4) Removing the Top Cover

1. Remove the Left Cover.
2. Remove the Panel Cover.

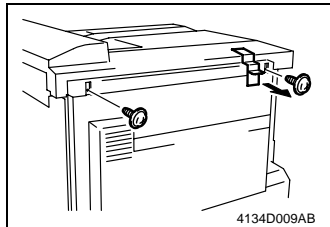

3. Remove two screws

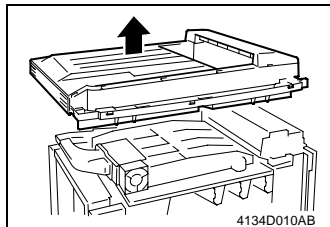

4. Remove the Top Cover.

(5) Remove the Ozone Filter Cover

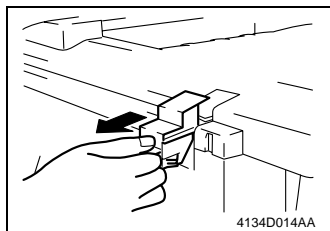

1. Grasp the Ozone Filter Cover handle, and pull it forward.

(6) Removing the Rear Cover

1. Remove the Left Cover.
2. Remove the Panel Cover.
3. Remove the Top Cover.
4. Remove the Ozone Filter Cover.

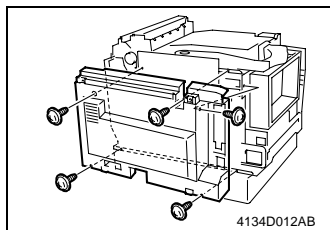

5. Remove five screws.
6. Remove the Rear Cover.

2-3. Removing Circuit Boards and other Electrical Components

NOTE

- When removing a circuit board or other electrical component, refer to Removal Procedures and follow the corresponding procedures.
- The following removal procedures omit the removal of connectors and screws securing the circuit board support or circuit board.
- If it is absolutely necessary to touch the ICs and other electrical components on the board, be sure to ground yourself.

<Engine>

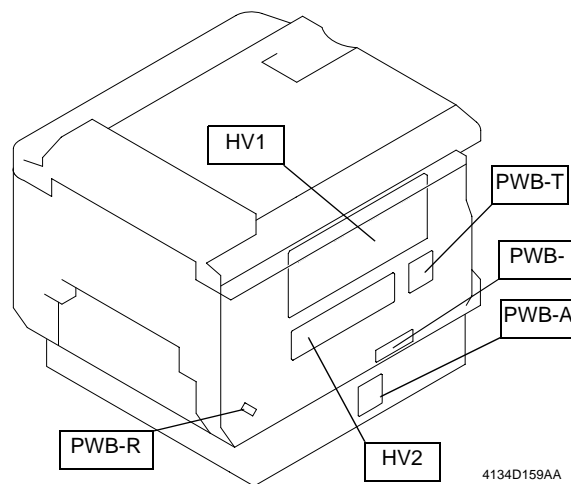
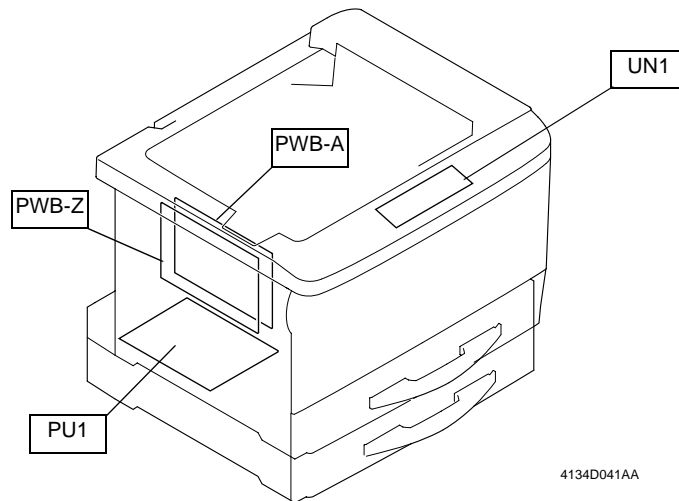

Symbol	Name	Removal Procedures
PWB-A	Control Board	☞ D-8
PWB-A	2nd Drawer Control Board	☞ D-13
PWB-R	High Resistance Board	☞ D-14
PWB-PS	1st Drawer Paper Size Detecting Board	☞ D-14
PWB-T	Heater Lamp Control Board	☞ D-15
PWB-Z	Controller Board	☞ D-12
PU1	DC Power Supply	☞ D-16
UN1	Control Panel	☞ D-17
HV1	High Voltage Unit 1	☞ D-17
HV2	High Voltage Unit 2	☞ D-17

(1) Removing the Control Board

<Removal Procedures>

1. Remove the Left Cover.
2. Remove the Panel Cover.
3. Remove the Top Cover.
4. Remove the Rear Cover.

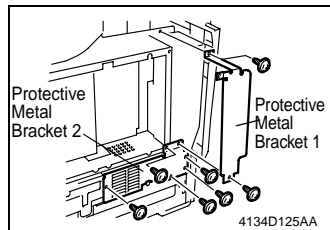

5. Remove the screw 8 and then remove the protective metal bracket 1 and 2.

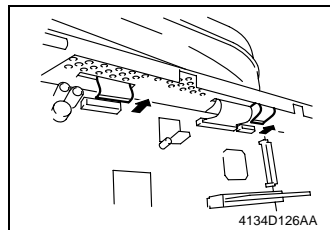

6. Remove one flat cable on the Controller Board.

NOTE

- Handle flat cables with care, being careful not to damage or cut them.

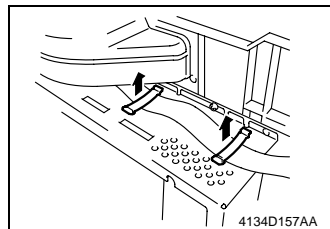

7. Detach 2 cable holders, and remove the flat cable.

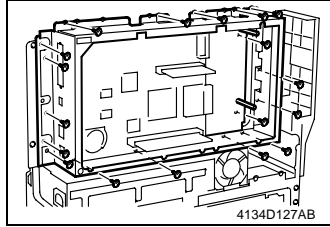

8. Remove eighteen screws.

NOTE

- Do not remove the screws in positions marked with an "O" on the Controller Box.

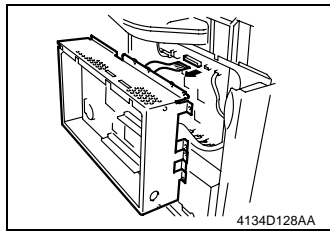

9. Remove one of the flat cables on the Control Board with the Controller Box slightly raised.
10. Remove the Controller Box.

11. Unplug all connectors on the Control Board.

12. Remove six screws, and then remove the Control Board.

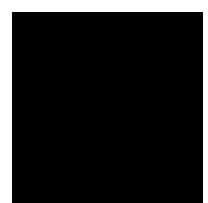
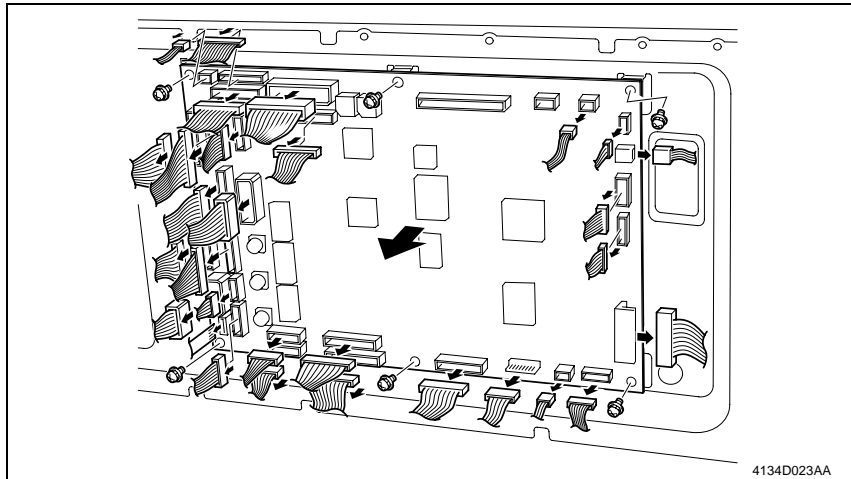

<Reinstallation procedures>

NOTE

- When replacing the Control Board, make sure to remove the EEPROM from the old Control Board and remount it onto the new board.

1. Replace the EEPROM.

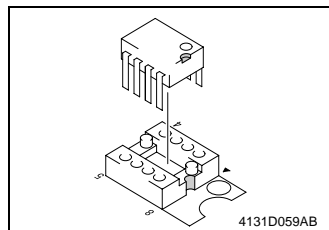
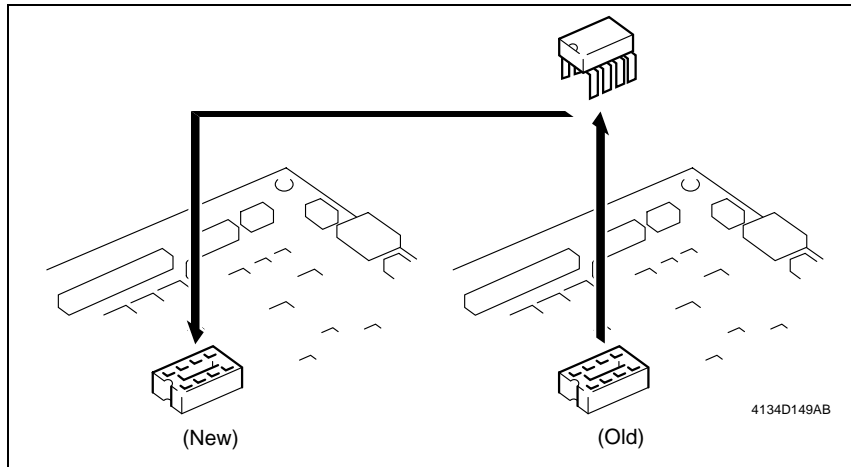

NOTE

- Ensure that the EEPROM is installed in the correct direction.

2. Secure the Control Board with six screws.
3. Reinstall all connectors removed in Removal Procedure 10.

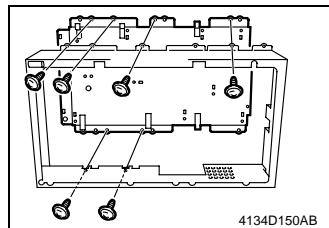

4. Remove the six screws in the "O" marked positions, and open the Controller Box.

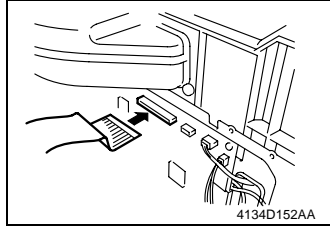

5. Attach one flat cable to the Control Board.

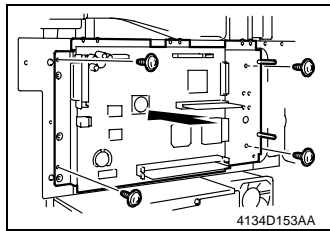

6. Use four screws to install Controller Box 1.

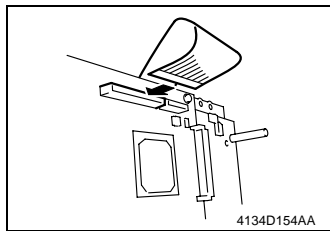

7. Attach one flat cable to the Control Board.

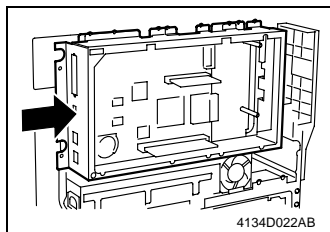

8. Position Controller Box 2 by sliding it in the direction of the arrow.

NOTE

- When passing the connector lock for the parallel port through the I/F portion of Controller Box 2, take care not to bend the connector lock.

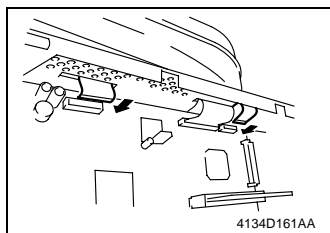

9. Attach 2 flat cables to the Control Board.

10. Reinstall Control Box 2 with twenty screws.
11. Secure the parallel port with two screws.

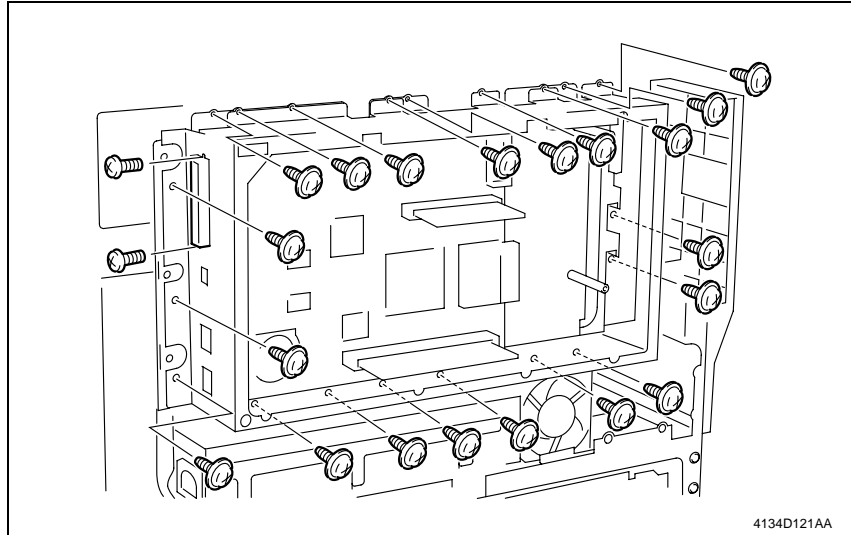

12. Reinstall protective plates 1 and 2 with eight screws.

(2) Removing the Controller Board

NOTE

- When replacing the Controller Board, make sure to remove the EEPROM (IC9) from the old Controller Board and remount it onto the new board.
- When replacing the Controller Board, make sure to remove the smartmedia card from the old Controller Board and remount it onto the new board.

1. Remove the Left Cover.
2. Remove the Panel Cover.
3. Remove the Top Cover.
4. Remove the Rear Cover.

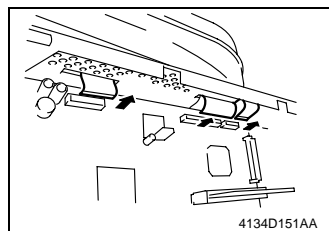

5. Remove three of the flat cables from the Control Board.

NOTE

- Take care not to damage or cut flat cables when handling them.

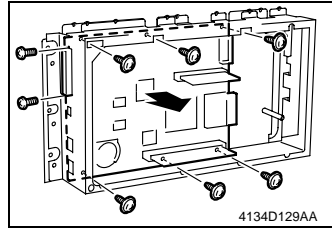

6. Remove eight screws, and then remove the Controller Board.

(3) Remove the 2nd Drawer Control Board

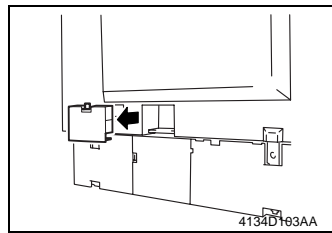

1. Remove the Connector Cover on the back of the main unit.

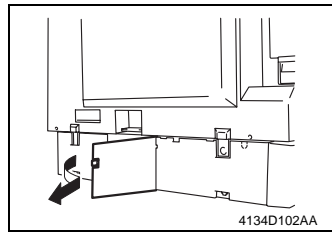

2. Remove the 2nd Drawer Rear Cover.

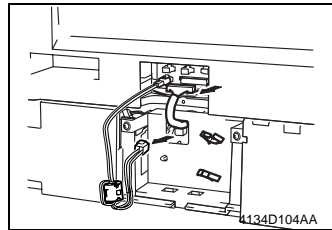

3. Unplug one Power Supply connector.
4. Remove the harness from the wire saddle.
5. Unplug one control connector.

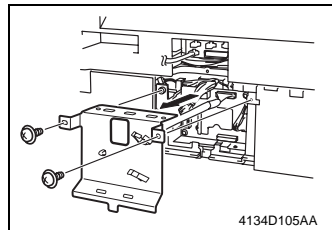

6. Remove two screws, and the PWB Cover.



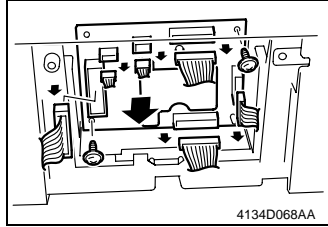

7. Remove all connectors from the 2nd Drawer Control Board.
8. Remove the PWB holder.
9. Remove two screws, and the 2nd Drawer Control Board.

(4) Removing the High Resistance Board

1. Remove the Left Cover.
2. Remove the Panel Cover.
3. Remove the Top Cover.
4. Remove the Rear Cover.

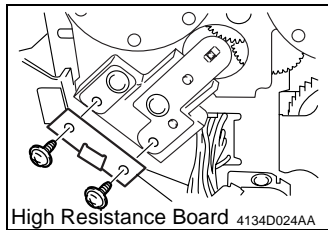

5. Remove two screws, and the High Resistance Board.

(5) Removing the First Drawer Paper Size Detecting Board

1. Remove the Left Cover.
2. Remove the Panel Cover.
3. Remove the Top Cover.
4. Remove the Rear Cover.
5. Remove High Voltage Units 1 and 2.

 [D-17](#)

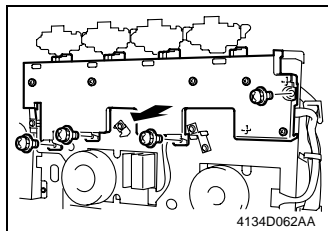

6. Remove four screws, and the PWB support.

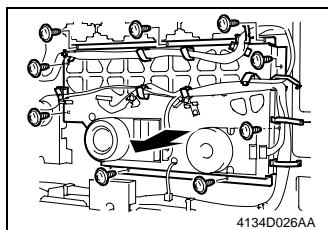

7. Remove twelve wire saddles.
8. Remove nine screws, and the Print Unit Drive Unit.

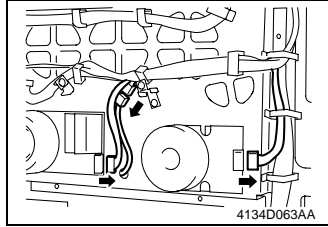

9. Remove all of the connectors on the Print Unit Drive Motor Bk/YMC Board.
10. Remove the Interface Connector for the 1st Image Transfer Pressure/Retraction Clutch.

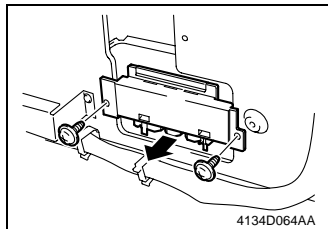

11. Remove two screws.

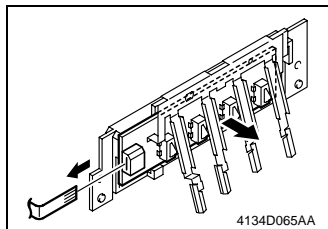

12. Remove the flat cable, and the First Drawer Paper Size Detecting Board.

(6) Removing the Heater Lamp Control Board

1. Remove the Left Cover.
2. Remove the Panel Cover.
3. Remove the Top Cover.
4. Remove the Rear Cover.

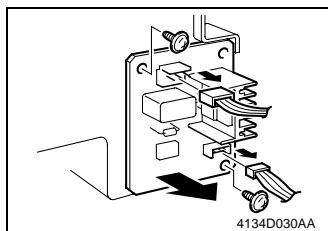

5. Unplug all connectors on the Heater Lamp Control Board.
6. Remove two screws, and the Heater Lamp Control Board.

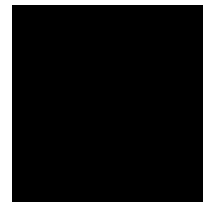

(7) Removing the DC Power Supply

1. Remove the Controller Box.

☞ D-8(Removal Procedures 1 through 9 for the Control Board)

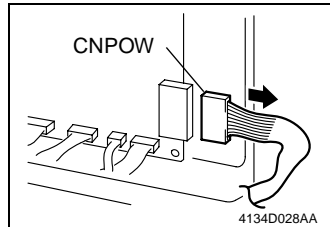

2. Disconnect one connector from the Control Board.

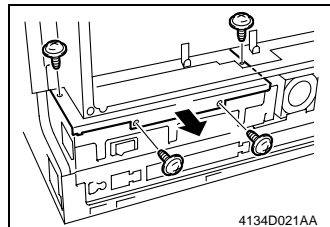

3. Remove four screws, and the Power Supply Box Cover.

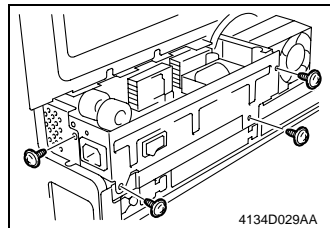

4. Remove four screws, and the Power Supply Box.

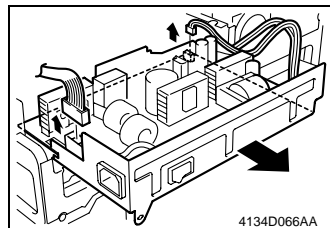

5. Remove all of the connectors on the DC Power Supply.

6. Remove the DC Power Supply Assembly.

(8) Removing the Control Panel

1. Remove the Panel Cover.

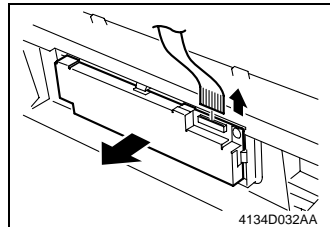

2. Remove the flat cable, and Control Panel.

(9) Removing High Voltage Units 1 and 2

1. Remove the Left Cover.
2. Remove the Panel Cover.
3. Remove the Top Cover.
4. Remove the Rear Cover.

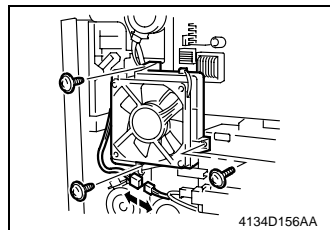

5. Remove three screws, and unplug one connector. Then remove the Print Unit Cooling Fan.

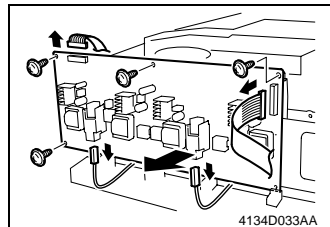

6. Remove all connectors on High Voltage Unit 1.
7. Remove four screws, and High Voltage Unit 1.

Precautions when installing High Voltage Unit 1

- Make sure that the contact on the High Voltage Unit 1 Board and the spring on back of the main unit make a good connection.
 - Do not bend the spring.
-

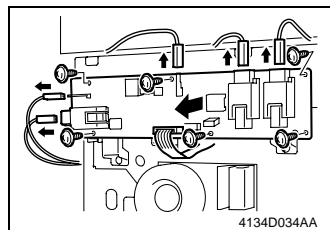

8. Remove all connectors on High Voltage Unit 2.
9. Remove six screws and High Voltage Unit 2.

<Manual Feed Unit (optional)>

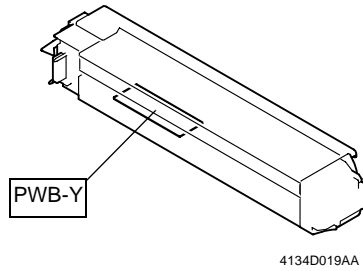

Symbol	Name	Removal Procedures
PWB-Y	Manual Feed Detecting Board	☞ D-18

(1) Removing the Manual Feed Detecting Board

1. Remove the Manual Feed Unit.

☞ D-25

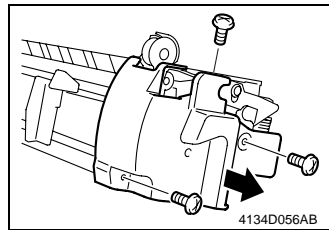

2. Remove three screws, and the Right Cover.

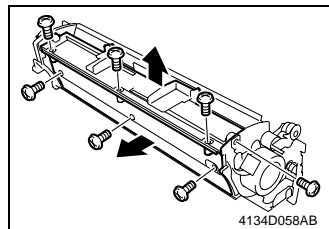

3. Remove seven screws, and the Front and Lower Covers.

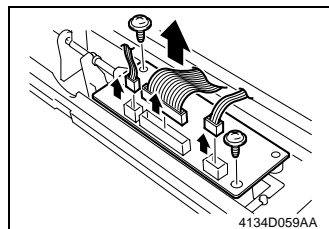

4. Remove all of the connectors on the Manual Feed Detecting Board.

5. Remove two screws, and the Manual Feed Detecting Board.

<Duplex Unit (optional)>

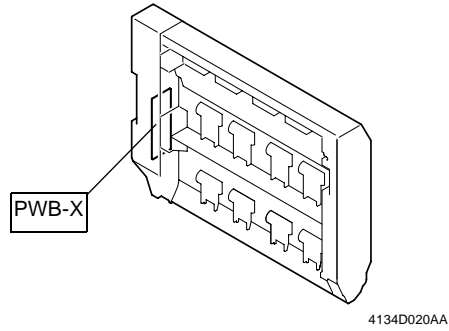

Symbol	Name	Removal Procedures
PWB-X	Duplex Control Board	☞ D-19

(1) Removing the Duplex Unit Control Board

1. Remove the Duplex Unit.

☞ D-26

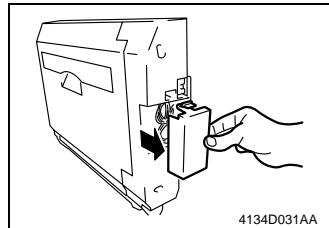

2. Remove the Interface Connector Cover.

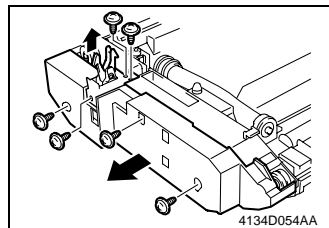

3. Remove six screws, and the Right Cover.

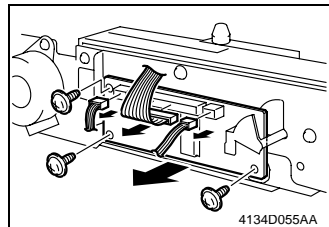

4. Remove all of the connectors on the Duplex Unit Control Board.

5. Remove three screws and the Duplex Unit Control Board.

<Paper Feed Unit (optional)>

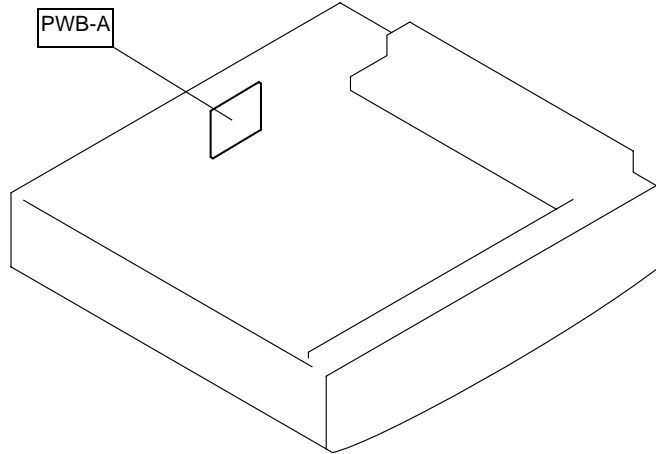

4134D101AA

Symbol	Name	Removal Procedures
PWB-A	Control Board	⇒ D-20

(1) Removing the Paper Feed Unit Control Board

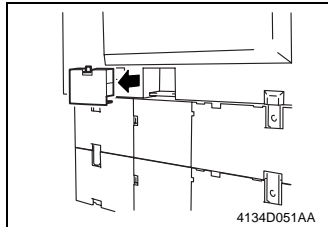

1. Remove the Connector Cover from the back of the main unit.

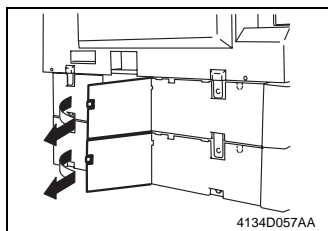

2. Remove the 2nd Drawer Rear Cover.
3. Remove the Paper Feed Unit Rear Cover.

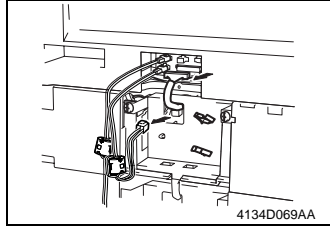

4. Remove the harness from the wire saddle.
5. Unplug two connectors.

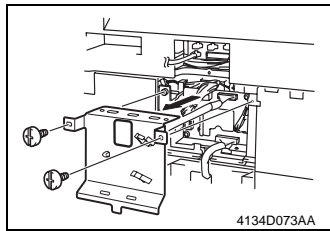

6. Remove two screws, and the PWB Cover.

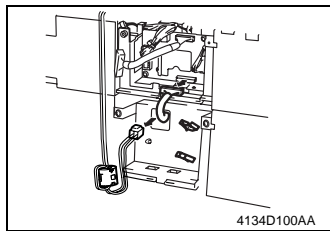

7. Remove the harness from the wire saddle.
8. Unplug two connectors.

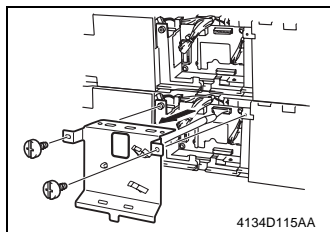

9. Remove two screws, and the PWB Cover.

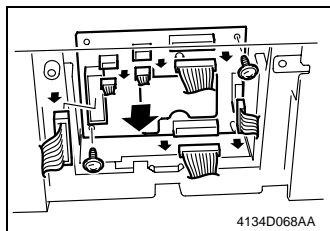

10. Unplug all connectors on the Control Board.
11. Remove the PWB holder.
12. Remove two screws, and then remove the Control Board.

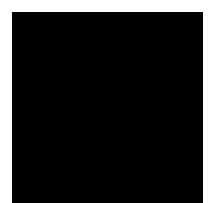

2-4. Removing Units

(1) Removing the Print Head Unit

NOTE



- Do not replace the Print Head Unit when the Power Supply is turned on.
Laser beam radiation may cause blindness.



- Do not disassemble or adjust the Print Head Unit.
Laser beam radiation may cause blindness.

1. Remove the Controller Box.

 [D-8\(Control Board Removal Procedures 1 through 9\)](#)

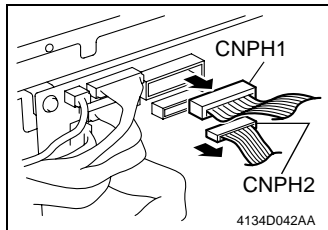

2. Unplug two connectors on the Control Board.

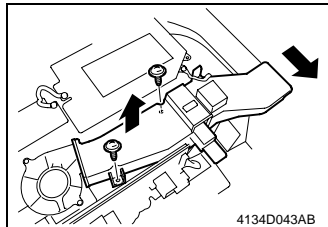

3. Remove two screws, and the Ozone Filter Duct.

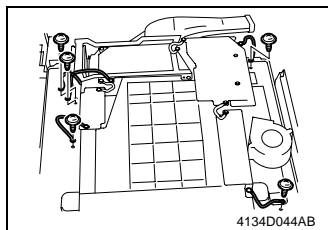

4. Remove five screws, and the ground wire.

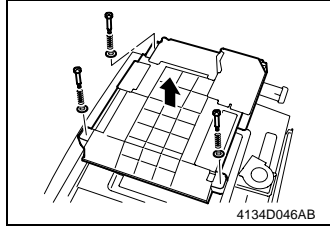

5. Remove three screws, and the Print Head Unit.

Precautions when removing/installing Print Head Units

- **DO NOT touch the rear window of the Print Head Unit.** The window may get dirty, resulting in a poor image quality.

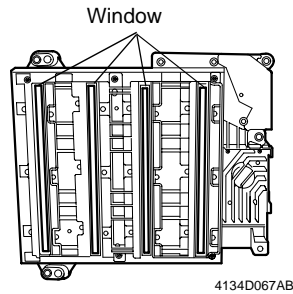

- When installing the Print Head Unit, make sure to align with the protrusion on the back side.

(2) Removing the 2nd Drawer

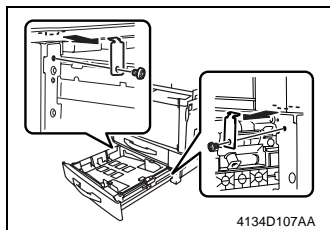

1. Slide out the drawer.
2. Remove two screws, and the guide plate.

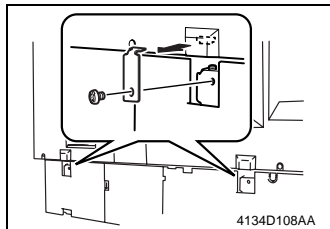

3. Remove two screws from the back of the 2nd Drawer, and then remove the guide plate.

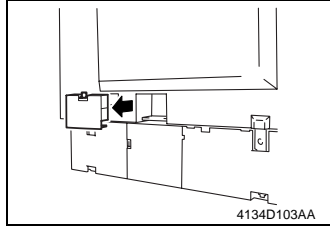

4. Remove the Connector Cover from the back of the main unit.

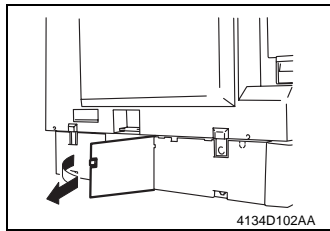

5. Remove the 2nd Drawer Rear Cover.

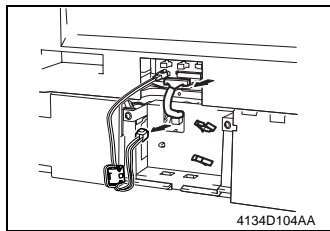

6. Remove the harness from the wire saddle.
7. Unplug two connectors.

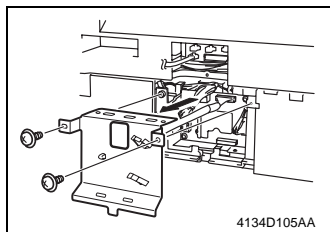

8. Remove two screws, and the PWB Cover.

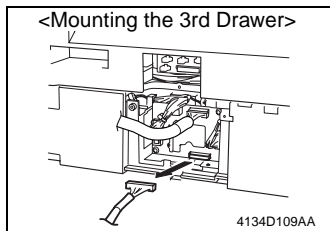

9. Remove the Manual Feed Unit.
☞ D-25

NOTE

- Be sure to unplug one connector when mounting the 3rd Drawer.
-

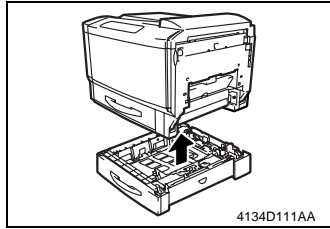

10. Lift the main unit, and remove the 2nd Drawer.

Precautions when attaching the Paper Feed Unit

- When installing the Paper Feed Unit, take care when handling the Power Supply harness, ferrite core, and Interface Connector as shown below.

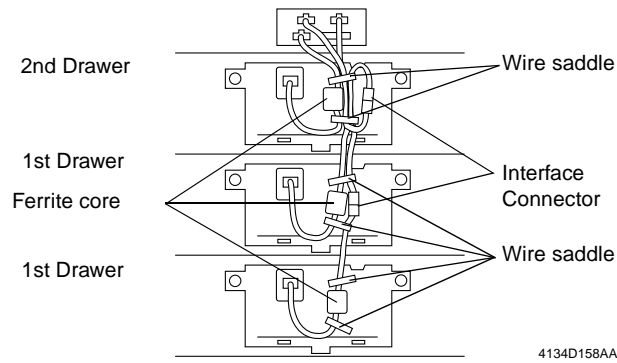

(3) Removing of the Manual Feed Unit (optional)

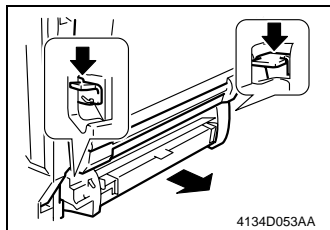

1. Pull forward while pressing the right and left release levers to remove the Manual Feed Unit.



(4) Removing the Duplex Unit (optional)

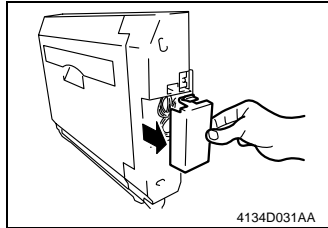

1. Remove the Interface Connector Cover.

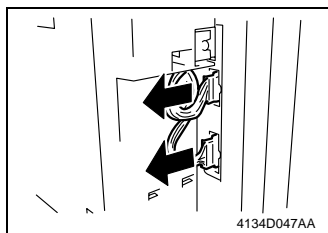

2. Remove the Interface Connector.

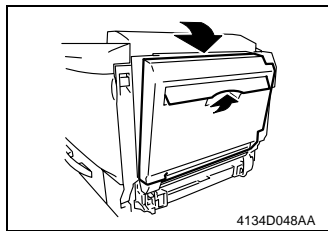

3. Open the Duplex Unit Cover.

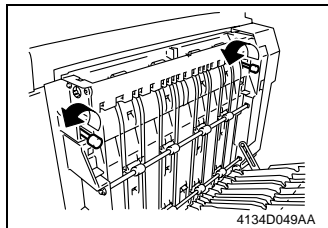

4. Loosen two screws.

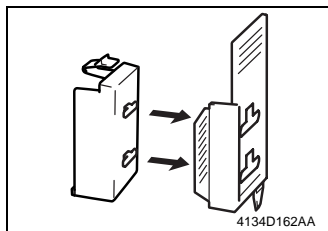

5. Remove the wire stopper removal jigs from the Interface Connector.

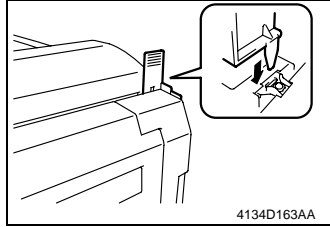

6. Remove the hook using the wire stopper removal jig.

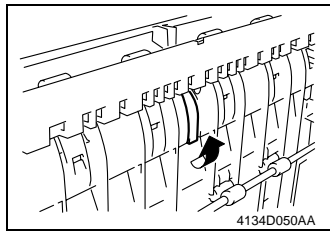

7. Pull the lock lever to release the lock.

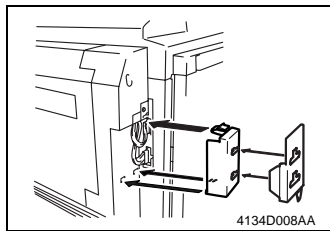

NOTE

- Reinstall the removal jigs to the Interface Connector Cover on the right side of the Duplex Unit.

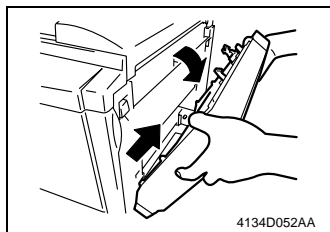

8. Tilt the Duplex Unit forward, and remove by lifting in a diagonal direction.

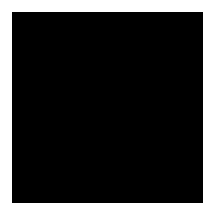

(5) Removing of the Paper Feed Unit (optional)

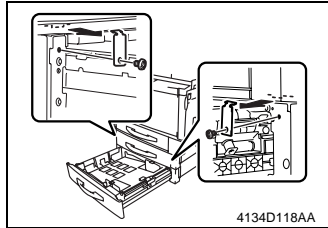

1. Slide out the drawer.
2. Remove two screws and the guide plate.

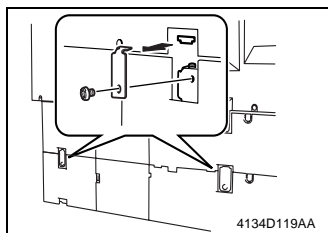

3. Remove two screws from the back of the paper feed unit, and then remove the guide plate.

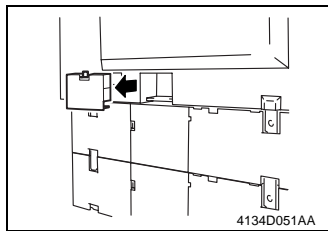

4. Remove the Connector Cover from the back of the main unit.

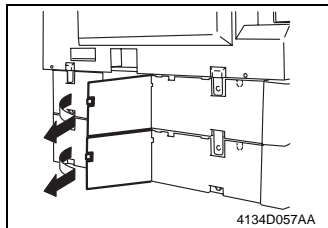

5. Remove the Paper Feed Unit Rear Cover.

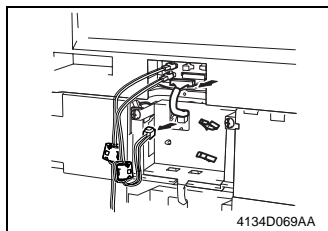

6. Remove the harness from the wire saddle.
7. Unplug two connectors.

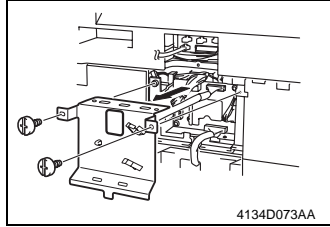

8. Remove two screws, and the PWB Cover.

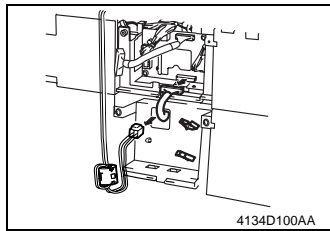

9. Remove the harness from the wire saddle.
10. Unplug two connectors.

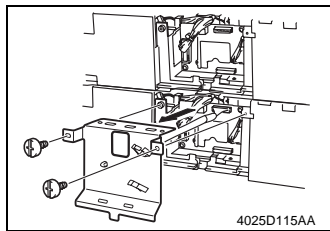

11. Remove four screws, and the PWB Cover.

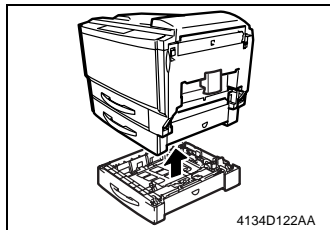

12. Lift the main unit to remove the Paper Feed Unit.

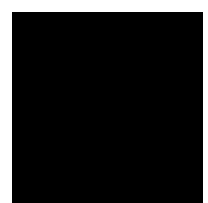

Precaution for Reinstallation of Paper Feed Unit

- When installing the paper feed unit, take care when handling the Power Supply harness, ferrite core and Interface Connector, as shown below.

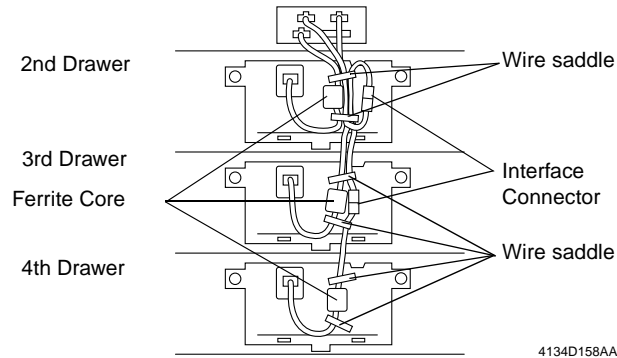

4134D158AA

2-5. Cleaning and Disassembly of the Engine Parts

(1) Composition of Transfer Belt Unit

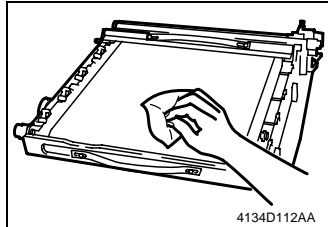

1. Remove the Transfer Belt Unit.
☞ E-22 (Maintenance schedule)
2. Wipe the surface of the Transfer Belt with a dry cloth.

NOTE

- If the dry cloth is not effective in removing dirt, dampen it with toner or waste toner.
- Do not use a cloth wet with water.
- If any solvent is to be used, select one from among the following:
IPA, ethyl alcohol, PPC Cleaner, and Solmix AP-7.
- When the solvent has been used for cleaning, make 28 or more copies using A3 blank sheets of paper to remove image noise.

(2) Cleaning of the Fusing Entrance Guide Plate

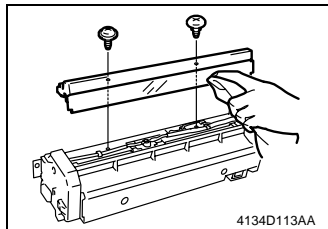

1. Remove the Fuser Unit.
☞ E-19 (Maintenance schedule)
2. Remove one screw, one stepped screw and the Fusing Entrance Guide Plate Assy.
3. Using a dry cloth or cotton swab dampened with alcohol, wipe clean the Fusing Entrance Guide Plate.

NOTE

- Use care when cleaning the Fusing Entrance Guide Plate as it is easy to damage.
- Be careful because the Fuser Unit can be hot.
- Do not set down the Fuser Unit with its terminal down.

(3) Cleaning the Print Head Unit window surface

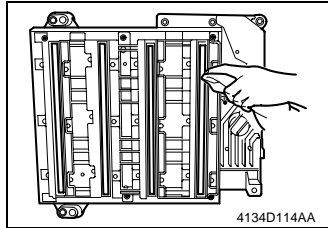

1. Remove the Print Head Unit.
☞ D-22
2. Using a dry cloth or cotton swab dampened with alcohol, wipe clean the window surface.

(4) Cleaning the AIDC Sensor

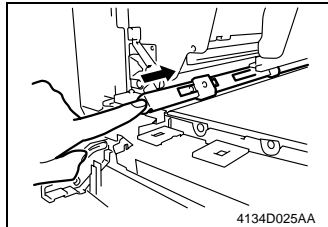

1. Open the Front Door.
2. Turn the lever once or twice.

NOTE

- Leave the Print Unit and Print Unit Support Bar mounted.
- The AIDC sensor is cleaned at the same time as closing the print unit support lever because the AIDC sensor cleaning lever synchronizes with the print unit support lever.

(5) Removing the Paper Feed Drive Motor

1. Remove the Left Cover.
2. Remove the Panel Cover.
3. Remove the Top Cover.
4. Remove the Rear Cover.

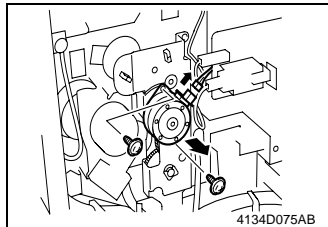

5. Unplug one connector.
6. Remove two screws, and the Paper Feed Drive Motor.

(6) Removing the Transport Drive Motor

1. Remove the Left Cover.
2. Remove the Panel Cover.
3. Remove the Top Cover.
4. Remove the Rear Cover.

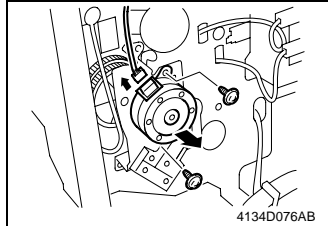

5. Unplug one connector.
6. Remove two screws, and the Transport Drive Motor.

(7) Removing the Fusing Drive Motor

1. Remove the Left Cover.
2. Remove the Panel Cover.
3. Remove the Top Cover.
4. Remove the Rear Cover.

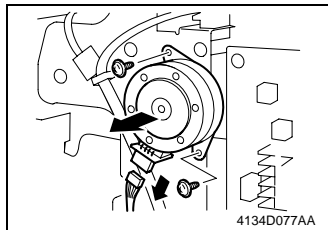

5. Unplug one connector.
6. Remove two screws, and the Fusing Drive Motor.

(8) Removing the Print Unit Drive Motor YMC/Bk

1. Remove the Left Cover.
2. Remove the Panel Cover.
3. Remove the Top Cover.
4. Remove the Rear Cover.

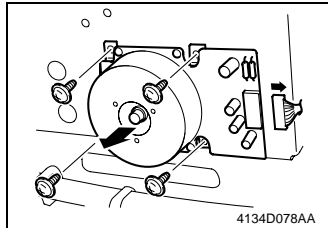

5. Unplug one connector.
6. Remove four screws, and the Print Unit Drive Motor Bk.

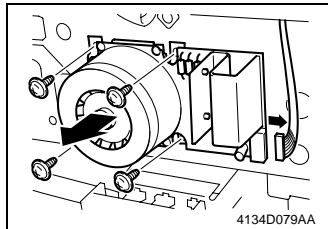

7. Unplug one connector.
8. Remove four screws, and the Print Unit Drive Motor YMC.

(9) Removing the 1st Image Transfer Pressure/Retraction Clutch

1. Remove the Print Unit Drive Unit.

⇒ [D-14 \(Procedures1through9\)](#)

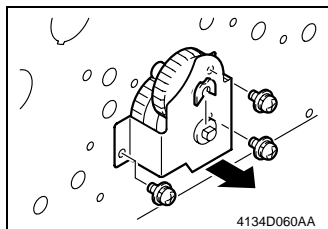

2. Remove three screws.
3. Snap off the C-clip and remove the 1st Transfer Pressure/Retraction Clutch mounting bracket.

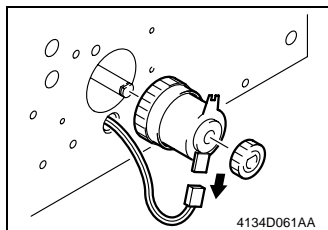

4. Unplug one connector, and then the 1st Image Transfer Pressure/Retraction Clutch.

(10) Remove the 2nd Drawer Paper Take-Up Clutch

1. Remove the 2nd Drawer.

☞ D-23

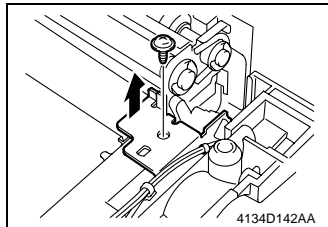

2. Remove one screw, and the Paper Feed Sensor mounting bracket.

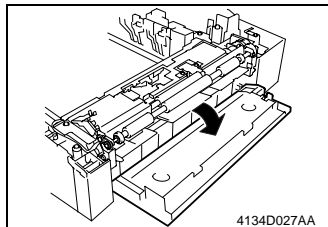

3. Open the Right Side Cover.

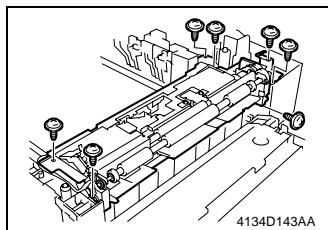

4. Remove seven screws, and the Paper Take-Up Drive.

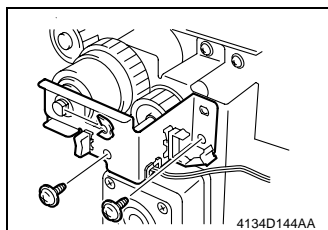

5. Snap off the C-clip.
6. Remove two screws, and the Paper Take-Up Clutch holder for the 2nd Drawer.

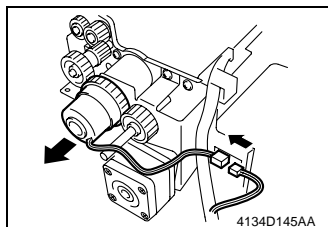

7. Unplug one connector, and the Paper Take-Up Clutch for the 2nd Drawer.

(11) Remove the Paper Take-Up Motor for the 2nd Drawer

1. Remove the Paper Take-Up Clutch for the 2nd Drawer.

☞ D-35

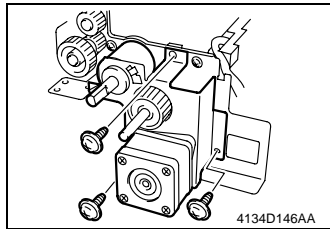

2. Snap off the C-clip, remove two screws, and the Paper Take-Up Motor for the 2nd Drawer.

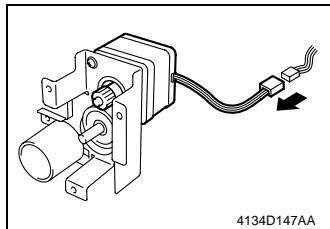

3. Unplug one connector.

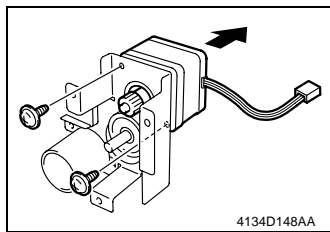

4. Remove two screws, and the Paper Take-Up Motor for the 2nd Drawer.

(12) Removing the Registration Sensor

1. Open the Front Door.
2. Remove the Print Unit.
☞ E-10 (Maintenance schedule)
3. Remove the Transfer Belt Unit.
☞ E-22(Maintenance schedule)
4. Remove the Controller Box.
☞ D-8(Removal Procedure 1through 9for the Control Board)

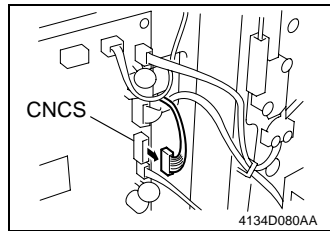

5. Unplug one connector on the Control Board.

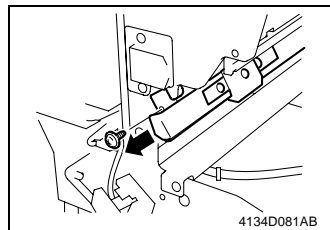

6. Remove one screw, and the AIDC/Registration Sensor mounting bracket.

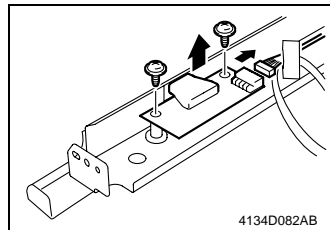

7. Unplug one connector.
8. Remove two screws, and the AIDC/Registration Sensor.

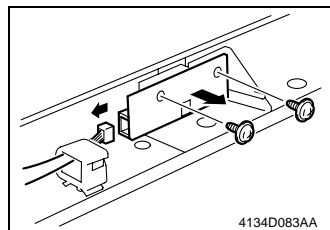

9. Unplug one connector.
10. Remove two screws, and the Registration Sensor.

(13) Removing the Temperature/Humidity Sensor

1. Open the Front Door.
2. Remove the Print Unit.
☞ E-10 (Maintenance schedule)
3. Remove the Transfer Belt Unit.
☞ E-22 (Maintenance schedule)

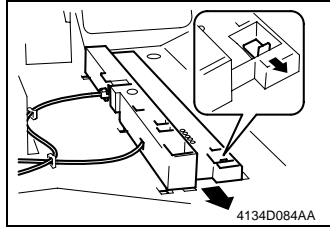

4. Pull the knobs forward, and slide the sensor holder forward to remove.

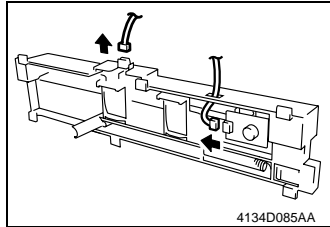

5. Unplug two connectors.

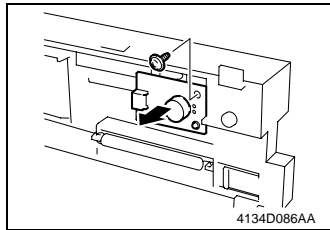

6. Remove one screw, and the Temperature/Humidity Sensor.

(14) Removing the Hard Disk Drive (optional)

1. Remove the Left Cover.

☞ D-5

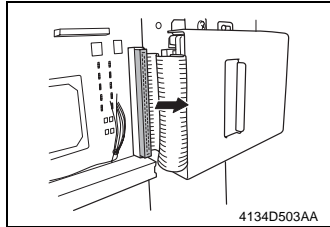

2. Remove the flat cables.

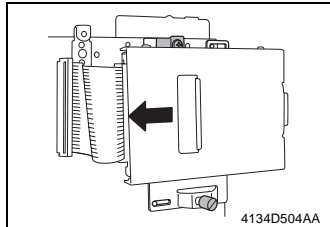

3. Remove one screw, and the Hard Disk Drive.

2-6. Disassembling the Manual Feed Unit (optional)

(1) Removing the Manual Feed Motor

1. Remove the Duplex Unit.

☞ D-26

2. Remove the Manual Feed Unit.

☞ D-25

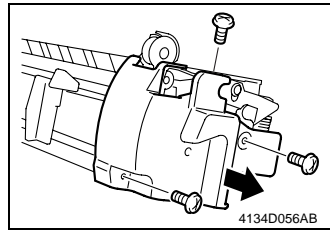

3. Remove three screws, and the Right Cover.

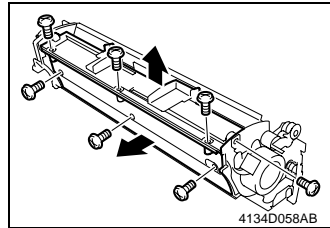

4. Remove seven screws, and the Rear Cover.

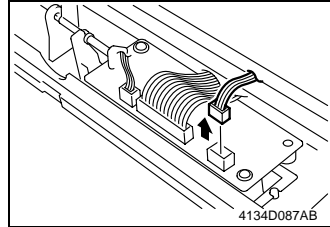

5. Unplug one connector.

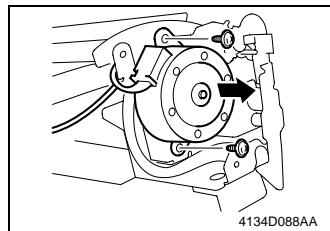

6. Remove the wire saddle, and the harness.

7. Remove two screws, and the Manual Feed Motor.

(2) Removing the Paper Take-Up Drive Roller

1. Remove the Duplex Unit.

☞ D-26

2. Remove the Manual Feed Unit.

☞ D-25

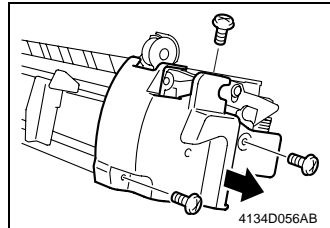

3. Remove three screws, and the Right Cover.

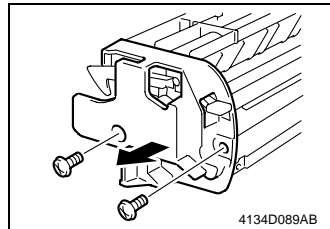

4. Remove two screws, and the Left Cover.

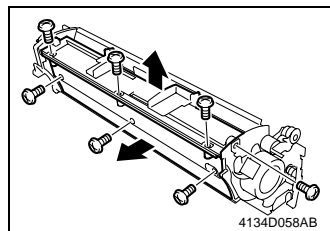

5. Remove seven screws, and the Front and Rear Cover.

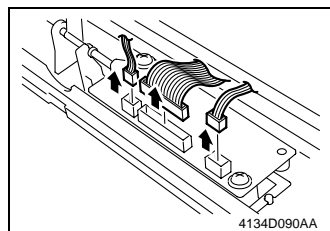

6. Unplug all the connectors on the Manual Feed Detecting Board.

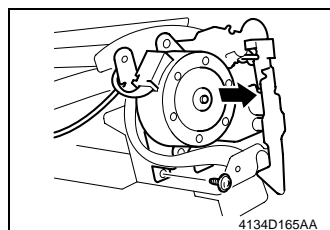

7. Remove the wire saddle and the harness.

8. Remove one screw, and the Manual Feed Motor Assembly.

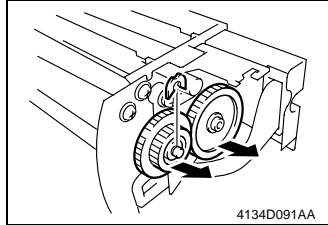

9. Snap off the C-clip, and remove two gears.

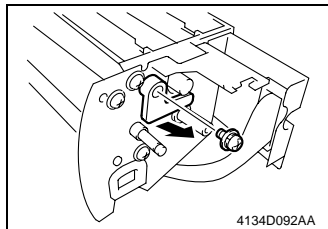

10. Remove one screw, and the lever.

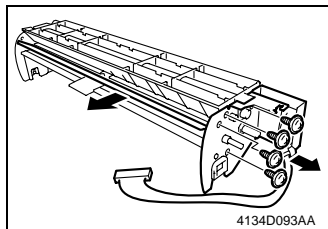

11. Remove four screws, and the right side plate and guide bracket.

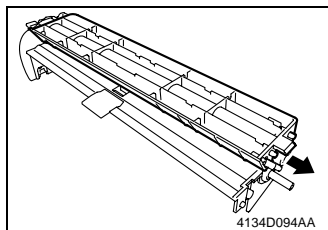

12. Remove the Top Cover.

NOTE

- When removing the Top Cover, take care not to lose the springs attached to both sides.
-

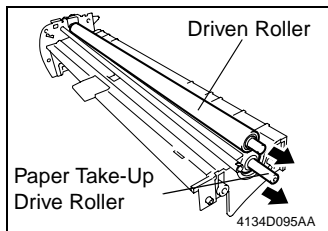

13. Remove the Driven Roller.

14. Remove the Paper Take-Up Drive Roller.

2-7. Disassembling the Duplex Unit (optional)

(1) Removing the Duplex Unit Drive Motor

1. Remove the Duplex Unit.

☞ D-26

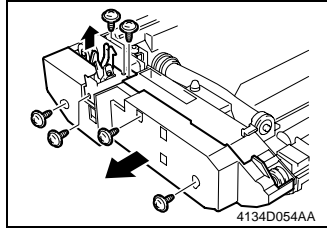

2. Remove six screws.
3. Remove Holder A, and the Right Cover.

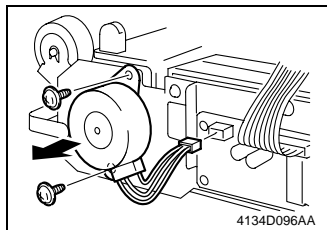

4. Unplug one connector on the Duplex Unit Control Board.
5. Remove two screws, and the Duplex Unit Drive Motor.

(2) Removing the Wire Stopper

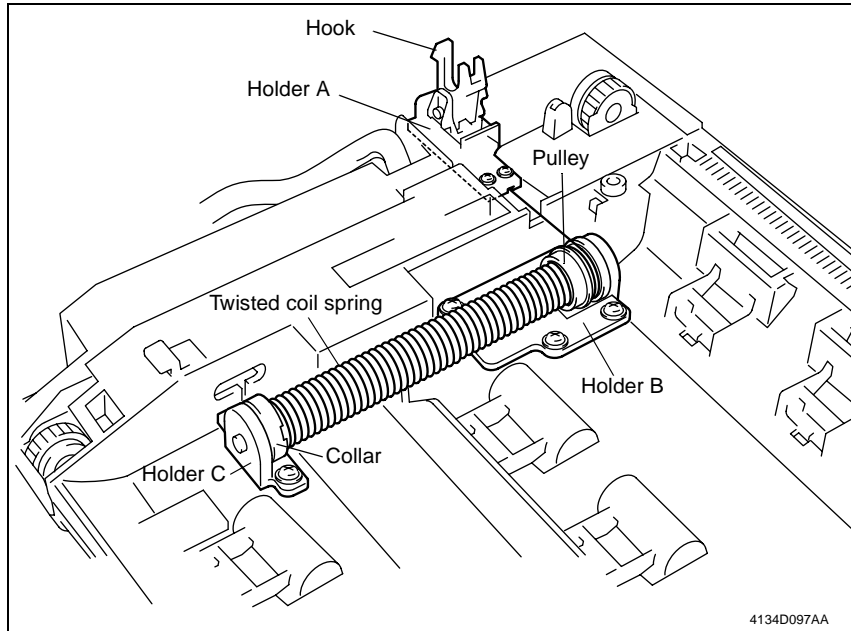

1. Remove the Duplex Unit.

⇒ D-26

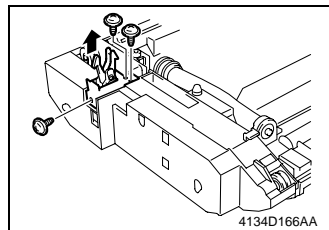

2. Remove three screws.
3. Remove Holder A.

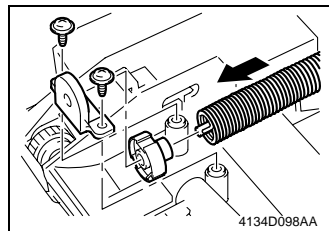

4. Remove two screws, and Holder C.
5. Remove the twisted coil spring, and the collar.

NOTE

- Take care when removing the twisted coil spring, as it may spring back and cause injury.

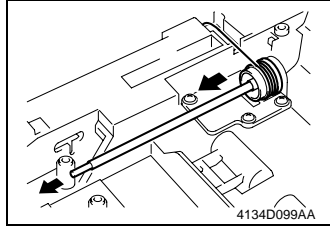

6. Remove the shaft.
7. Unhook the pulley.

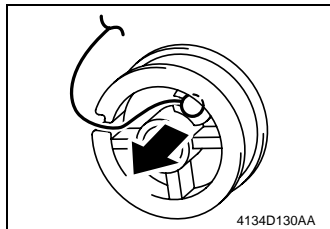

Pulley end

8. Remove the round bead on the wire stopper from the pulley.

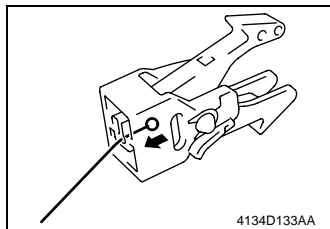

Hook end

9. Remove the round bead on the wire stopper from the hook.

<Reinstallation Procedure>

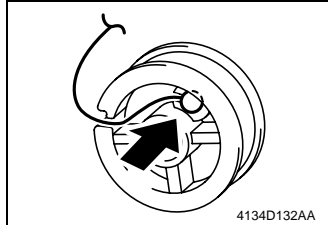

Pulley end

1. Position the round bead of the wire stopper in the pulley as shown.

NOTE

- Make sure that the bead snugly rests in the slit in the pulley.

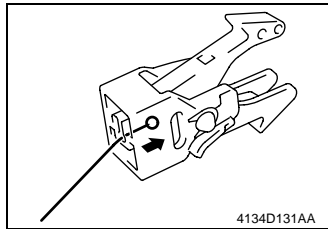

Hook end

2. Position the round bead of the wire stopper in the hook as shown.

NOTE

- Make sure that the bead snugly rests in the slit in Wire Holder A.
- Make sure that the bead snugly rests in the slit in the hook.

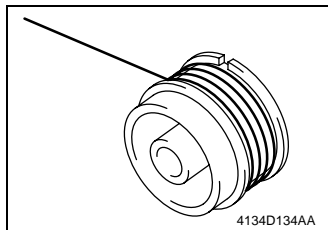

3. Wind the pulley end of the cable around the pulley five turns counter clockwise, from the rear toward the front.

NOTE

- Make sure that no part of the cable rides on the other.

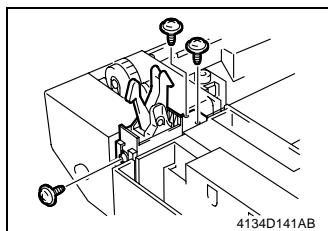

4. Install Holder A using three screws.

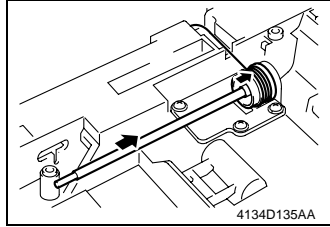

5. Secure the pulley onto Holder B.
6. Attach the shaft to Holder B.

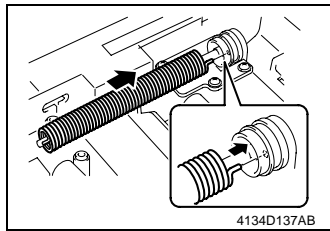

7. Attach the end of the twisted coil spring to the pulley.

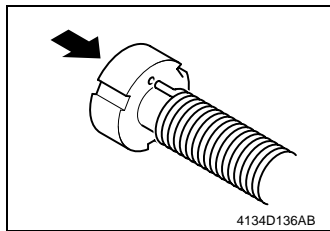

8. Attach the collar to the twisted coil spring.
9. Wind the collar and one and a third turns clockwise.

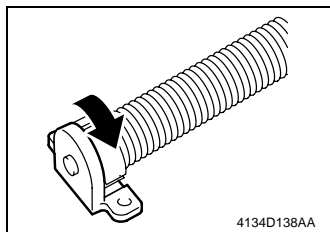

10. Attach Holder C to the collar.
11. Wind the collar and Holder C one and two thirds turn clockwise.

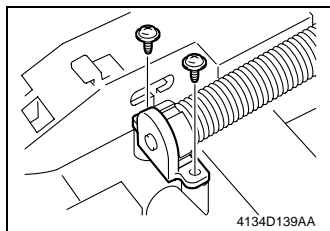

12. Attach Holder C using two screws.

13. Connect the Interface Connector.
14. Connect the Duplex Unit.

2-8. Disassembling the Paper Feed Unit (optional)

(1) Removing the Paper Take-Up Clutch

1. Remove the Paper Feed Unit.

☞ D-28

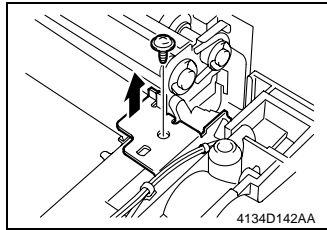

2. Remove one screw, and the Paper Feed Sensor mounting bracket.

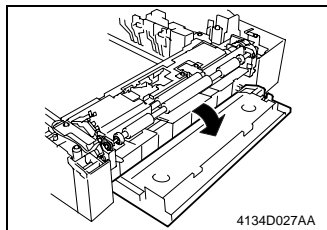

3. Open the Right Side Cover.

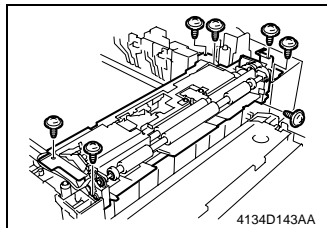

4. Remove seven screws, and the Paper Take-Up Drive.

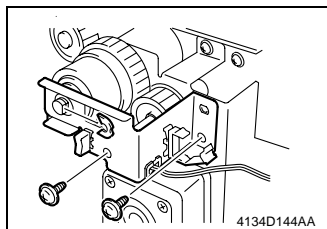

5. Remove the C-clip.
6. Remove two screws, and the Paper Take-Up Clutch holder.

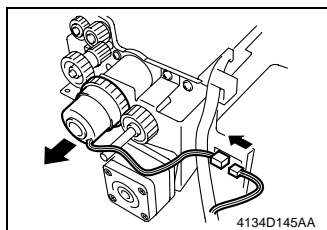

7. Unplug one connector, and remove the Paper Take-Up Clutch.

(2) Removing the Paper Take-Up Motor

1. Remove the Paper Take-Up Clutch.

☞ D-48

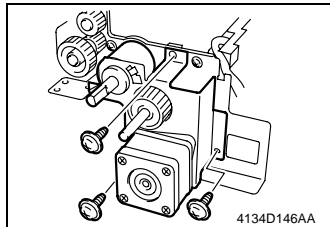

2. Snap off one C-clip and three screws, and remove the Paper Take-Up Motor mount bracket.

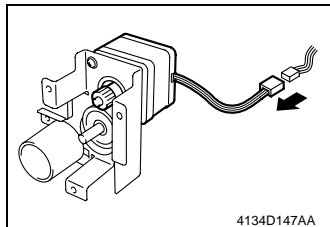

3. Unplug one connector.

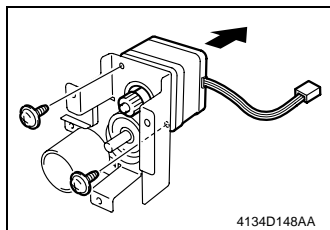

4. Remove two screws, and the Paper Take-Up Motor.

CONTROL PANEL/ Panel Menu Operations



1. CONTROL PANEL

1-1. Names and Functions of Control Panel Keys

- The Control Panel is comprised of a message window (16 characters × 2 lines), 5 indicators, 8 keys, and a buzzer.

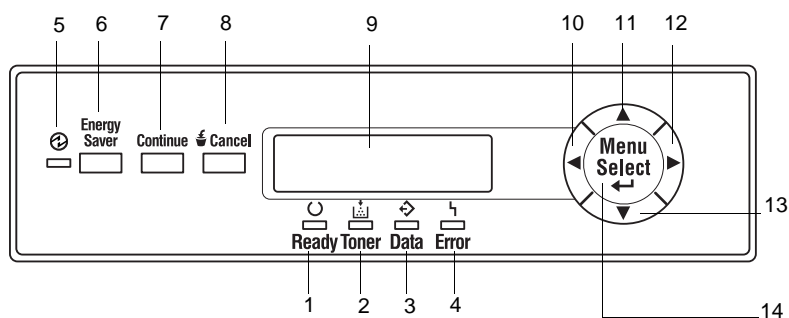

4134S502AA

No.	Name	OFF	ON
1	Ready Indicator	Menu Mode, Error Status, etc.	Lights up when the print function is enabled.
2	Toner Indicator	Conditions other than those to the right	ON Toner level is low or the Print Unit service life is almost over. Blinking: Toner empty or the Print Unit service life is almost over.
3	Data Indicator	Conditions other than those to the right	ON Transmission of print data has temporarily stopped but there is still data remaining to be printed. Blinking Print data is being transmitted or printing is taking place.
4	Error Indicator	No error	An error has occurred and printing is disabled.
5	Energy Saving Indicator	Standard mode	Power saving mode

No.	Name	Contents/Function
6	Energy Saver Key	Press this key in Power Saving Mode to release Power Saving Mode and return to Standard Mode. Press and hold this key for two seconds in Standard Mode to change to Deep Sleep mode.
7	Continue Key	Press this key to return from Menu Mode to Standard Mode.
8	Cancel Key	Cancel the print job. Cancel menu selection or settings modification in Menu Mode.
9	Message Window	Displays printer status or settings Information.
10	◀ Key	Menu configuration is moved to the left.
11	▲ Key	Menu configuration is moved up. Character count can be changed by entering the character count on the input screen.
12	▶ Key	The Menu is moved to the right.
13	▼ Key	Menu Configuration is moved down. Character count can be changed by entering the character count on the input screen.
14	Menu/Select Key	Change from Standard Mode to Menu Mode. Validate the menu displayed or the settings.
	Buzzer	The buzzer sounds when the switch is pressed or when an error occurs.

1-2. Control Panel Display

(1) Basic Screen

The Basic Screen is the Initialization Screen that displays when warm-up is complete or when the menu is cancelled.



READY
MAGICOLOR7300

C4134S028CA

(2) Warning Screen

The Warning Screen displays the following information depending on the type of warning.

<Malfunction display>

Displayed when the trouble cannot be corrected by the user.

Example



SERVICE CALL3047
PH FUN

C4134S029CA

<Error Display>

Displayed when an error occurs.

Example

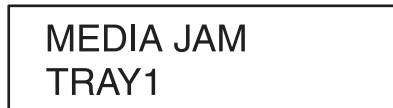

MEDIA JAM
TRAY1

C4134S037CA

<Caution Display>

Displayed when the Print Function is enabled, but user intervention is required.

Example



TONER LOW K

C4134S030CA

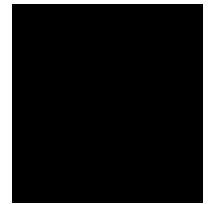

1-3. Control Panel Message

(1) Standard State Message

- The Standard State message displays at the top of the message window.

Message	Description
READY	• Print Enabled.
STANDBY MODE	• In Pre-heat Mode. Lower the Fusing Roller Temperature.
LIGHT SLEEP	• Engine is stopped. Turn the Fusing Roller Heater OFF.
PROCESSING	• Print Data Processing.
WARMING UP	• During warm-up
CALIBRATING	• Color Shift Correction in progress.

(2) Caution Message

- Caution messages are displayed at the bottom of the message window.

Message	Description
MAGICOLOR7300	• The product name displays when there is no caution message.
NO TRAYx	• Tray x removed.
NO MANUAL FEED	• Manual Feed Tray removed.
SIZE ERROR TRAYx	• Unsupported paper detected in tray x (excluding tray 1).
P-UNIT LOW x	• Print unit service life nearing end.
TONER LOW x	• Toner x level low
WASTE NEAR FULL	• Waste toner box near full.
FUSER LOW	• Fuser Unit replacement near due.
TRANS.BELT LOW	• Transfer belt unit replacement near due
PRINTER LIFE	• The operational life has been reached. * This is displayed only if the item "SWITH 2-2" is set to "ON" under "FACTORY SETTING" in the "SERVICE" menu.

* The higher the message, the greater the priority.

* When the printer is not READY, only the messages with high priority are displayed.

(3) Start-up Messages

Messages	Description
INITIALIZING	<ul style="list-style-type: none">• CPU INITIALIZATION, RAM Read/Write CHECK, TOTAL RAM CHECK, EEPROM CHECK, READ ETHERNET MAC ADDRESS.
MAGICOLOR 7300 TOTAL RAM:xxxMB	<ul style="list-style-type: none">• MAGICOLOR7300: Product Name• TOTAL RAM: Total Memory Capacity.
PROGRAM STARTING xxxxxxxxxxxxxxxx	<ul style="list-style-type: none">• Program is being read from SmartMedia to RAM.• xxxxxxxxxxxxxxxx: MAC Address.
INTIAL	<ul style="list-style-type: none">• PROGRAM INTIALIZING, NETWORK INITIALIZING, BEGIN COMMUNICATION WITH ENGINE.

(4) Operator Call Message

Message	Description	Action
MEDIA EMPTY ADD yy	• yy size paper not found in any tray. (Tray chain=ON)	• Load yy size paper in any tray.
TRAYx EMPTY ADD yy	• yy size paper not found in Tray x. (Tray chain=OFF)	• Load yy size paper in Tray x.
MANL EMPTY ADD yy	• yy size paper not found in Manual Feed Tray. (Tray chain=OFF)	• Load yy size paper in the Manual Feed Tray.
ADJUST TRAYS	• No trays installed. (Tray chain=ON)	• Install a tray.
AJUST TRAYx	• Tray x is not installed. (Tray chain=OFF)	• Install Tray x.
MEDIA JAM xx	• Paper jam in xx position	• Clear jammed paper.
COVER OPEN CHECK xx	• xx door is open	• Close the xx door.
TONER EMPTY REPLACE x	• toner x is empty	• Replace toner cartridge x.
PRINT UNIT END REPLACE x	• Service life of print unit x is over.	• Replace print unit x.
WASTE TONER FULL REPLACE BOX	• Waste toner box is full.	• Replace waste toner box.
TONER MISSING CHECK x	• Toner cartridge x is not installed.	• Install toner cartridge x
P-UNIT MISSING CHECK x	• Print unit x is not installed.	• Install print unit x
FUSER MISSING CHECK UNIT	• Fuser Unit is not installed.	• Install Fuser Unit.
NO MANUAL FEED CHECK UNIT	• Two-sided printing cannot be performed because Manual Feed Unit is not installed.	• Install Manual Feed Unit.
MEDIA SIZE ERR ADD yy	<ul style="list-style-type: none"> • yy paper size specified by the driver not found in any tray (Tray chain=ON, Auto Continue=NO) • Paper size other than yy size specified by the driver is loaded (Tray chain=ON, Auto Continue=NO) 	• Load yy paper size in any tray.

Message	Description	Action
TRAYx SIZE ERR ADD yy	<ul style="list-style-type: none"> Unsupported paper size detected in Tray x (excluding Tray 1). (Tray chain=ON) 	<ul style="list-style-type: none"> Load supported paper size in Tray x
	<ul style="list-style-type: none"> yy size paper specified by the driver not found in Tray x. (Tray chain=OFF, Auto Continue=NO) 	<ul style="list-style-type: none"> Load yy size paper specified by the driver in Tray x.
	<ul style="list-style-type: none"> Paper length other than yy size specified by the drive is loaded. (Tray chain=OFF, Auto Continue=NO) 	
TRAYx TYPE ERR ADD yy	<ul style="list-style-type: none"> An incorrect media type has been detected during printing. 	<ul style="list-style-type: none"> Load paper type (yy) specified by driver in Tray x.
MANL TYPE ERR ADD yy	<ul style="list-style-type: none"> An incorrect media type has been detected during printing. 	<ul style="list-style-type: none"> Load paper type (yy) specified by the driver in Manual Feed Tray.
MEMORY FULL PRESS CANCEL	<ul style="list-style-type: none"> Insufficient memory job cannot be processed. 	<ul style="list-style-type: none"> Press the CANCEL key to clear this message. Decrease the amount of data to be printed (for example, by decreasing the resolution), and then try printing again. Install an optional expansion memory.
PRINT UNIT ERROR REPLACE x	<ul style="list-style-type: none"> Failure in print unit x 	<ul style="list-style-type: none"> Replace print unit x.
WASTE TONER ERR REPLACE BOX	<ul style="list-style-type: none"> Failure in waste toner box. 	<ul style="list-style-type: none"> Replace waste toner box.
MANL FEED ERROR REMOVE MEDIA	<ul style="list-style-type: none"> Two-sided printing cannot be executed because Manual Feed Tray is empty. 	<ul style="list-style-type: none"> Remove paper from Manual Feed Tray.
OUTPUT FULL REMOVE MEDIA	<ul style="list-style-type: none"> Paper output tray full. 	<ul style="list-style-type: none"> Remove paper from output tray.

(5) SERVICE CALL MESSAGE

Message	Description
SERVICE CALL Cxx yyyyyyy	<ul style="list-style-type: none"> Failure in engine or controller. Cxx: service call ID, yyyyyyy: error content
SERVICE CALLLxxx yyyyyyy	<ul style="list-style-type: none"> Failure in engine or controller. xxx: service call ID, yyyyyyy: error content

* REFER TO TROUBLESHOOTING FOR INSTRUCTIONS.

1-4. Canceling a Print Job

- Print jobs currently under processing or printing can be cancelled by pressing the Cancel key.
1. The following message is displayed in the control panel when the Cancel key is pressed during printing of a print job.



YES:PRESS CANCEL
NO:PRESS CONT.

4134D519AA

2. Pressing the Cancel key cancels the job.



PROCESSING

4134D521AA



CANCELING JOB

4134D523AA

2. PANEL MENU

2-1. Summary of Panel Menu

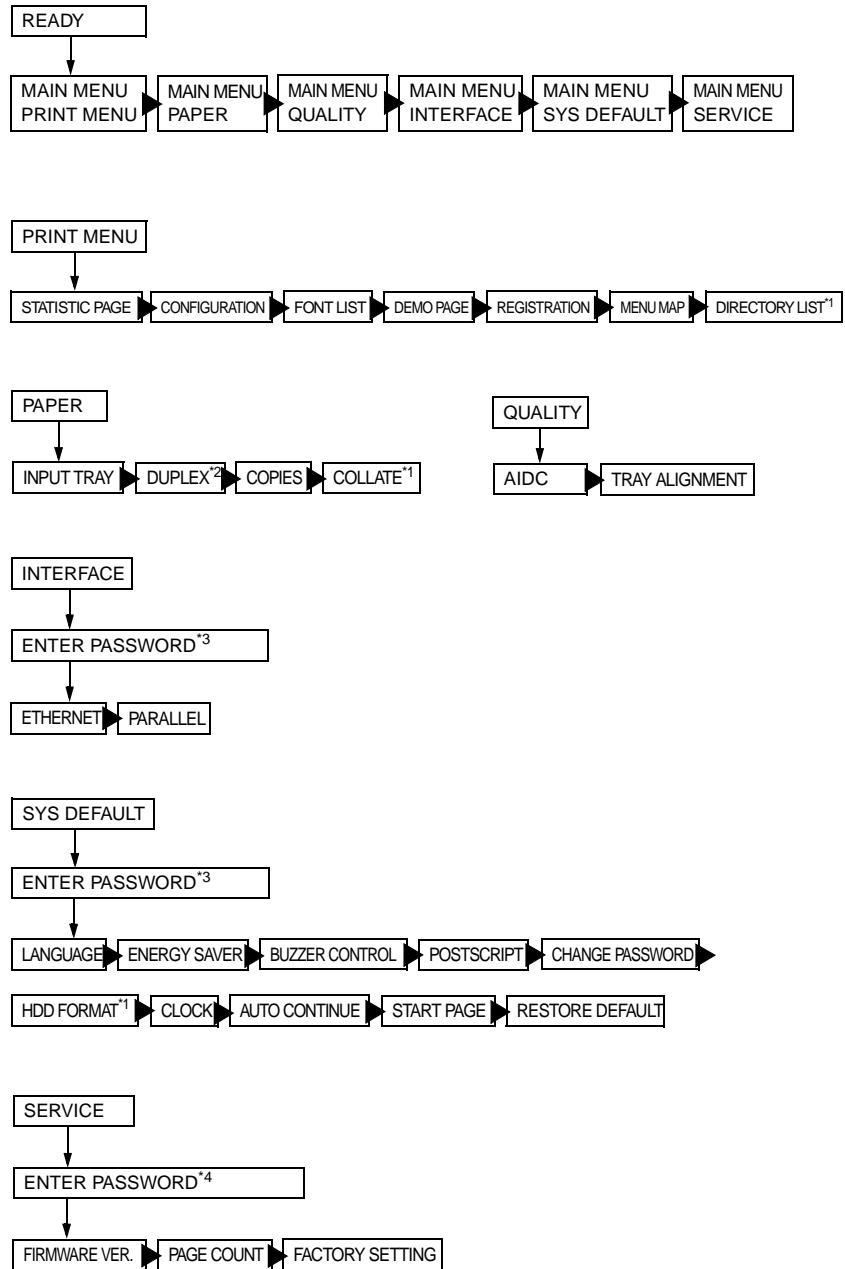

- *1: Displayed when HDD is mounted.
- *2: Displayed when Duplex Unit is mounted.
- *3: Enter password to access selected menu (not displayed when a password has not been activated).
- *4: Enter password to access selected menu.

2-2. Sub-menu

(1) PAPER

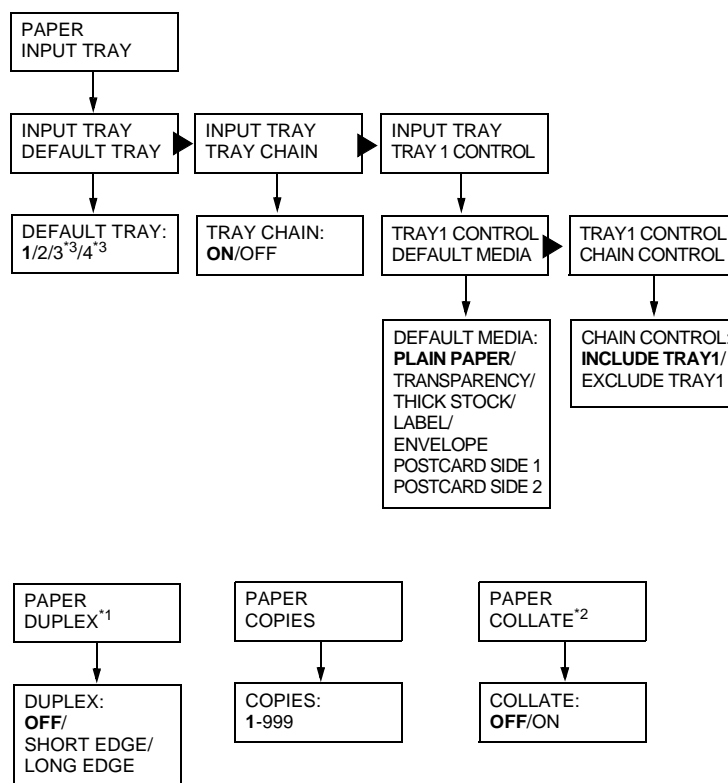

DEFAULT IS UPPERCASE

- *1: Displayed when Duplex Unit is mounted.
- *2: Displayed when HDD is mounted.
- *3: Displayed when Add-on Cassette is mounted.

(2) QUALITY

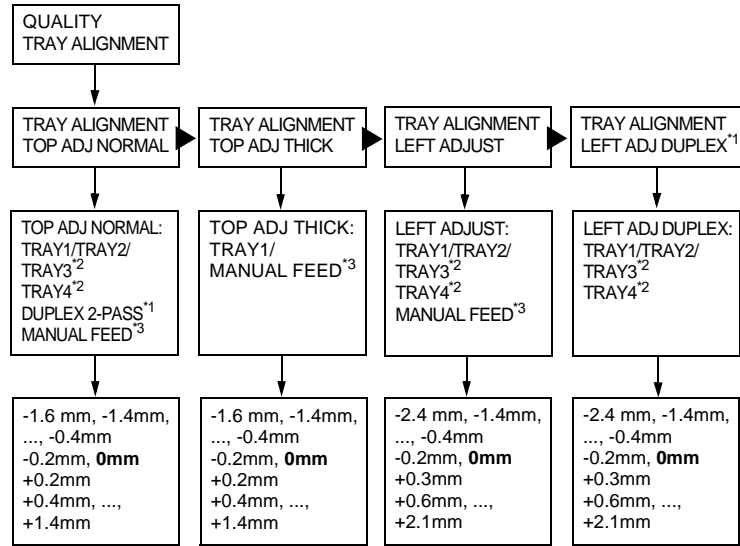
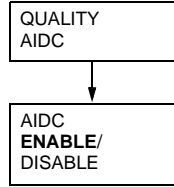

DEFAULT IS UPPERCASE

*1: Displayed when Duplex Unit is mounted.

*2: Displayed when Add-on Cassette is mounted.

*3: Displayed when Manual Feed Unit is mounted.

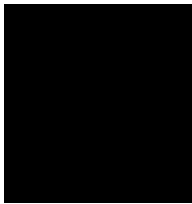

(3) INTERFACE

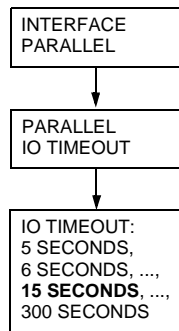
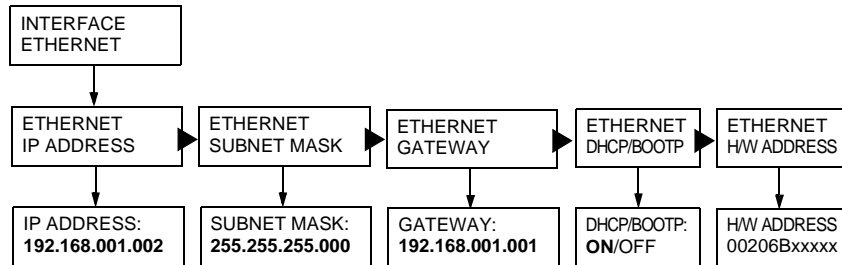

DEFAULT IS UPPERCASE

(4) SYS DEFAULT

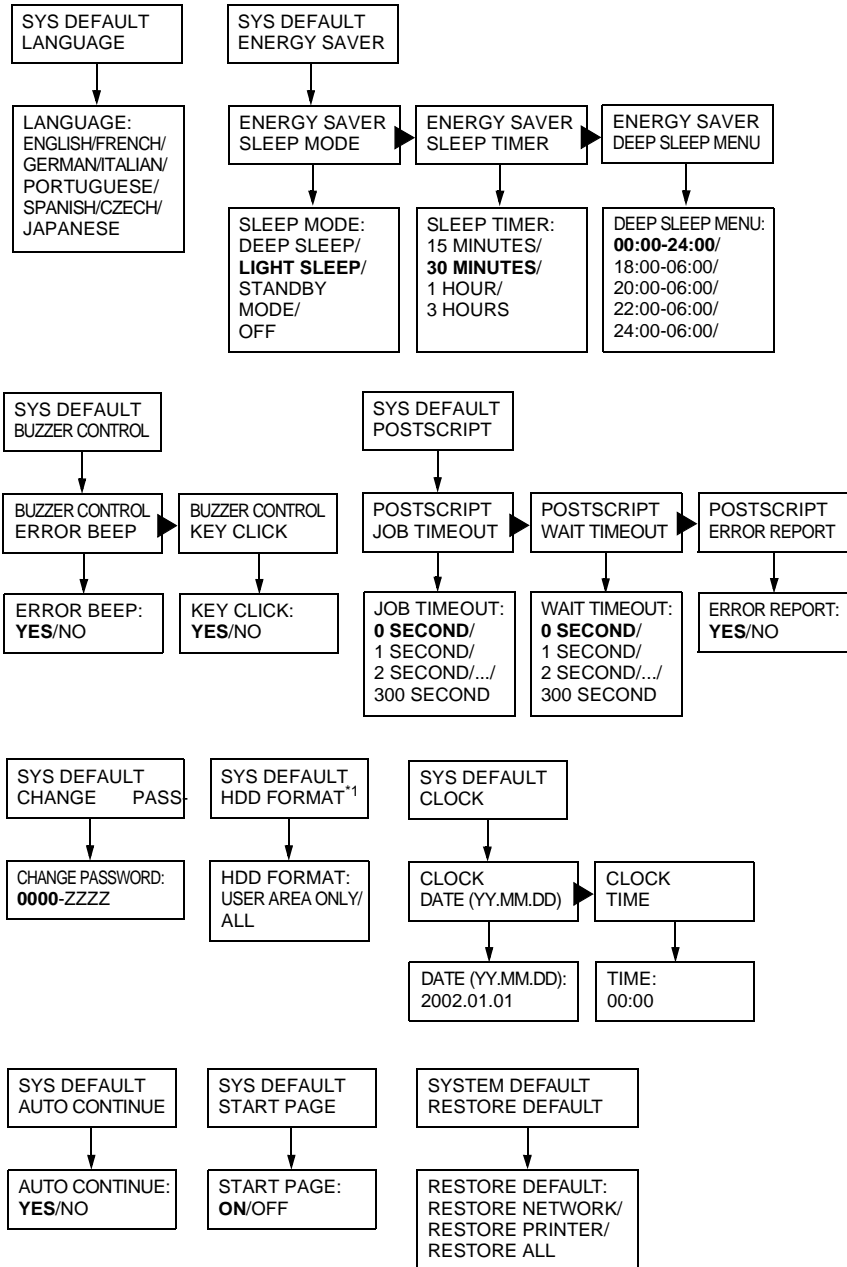

DEFAULT IS UPPERCASE
*1: Displayed when HDD is mounted.

(5) SERVICE

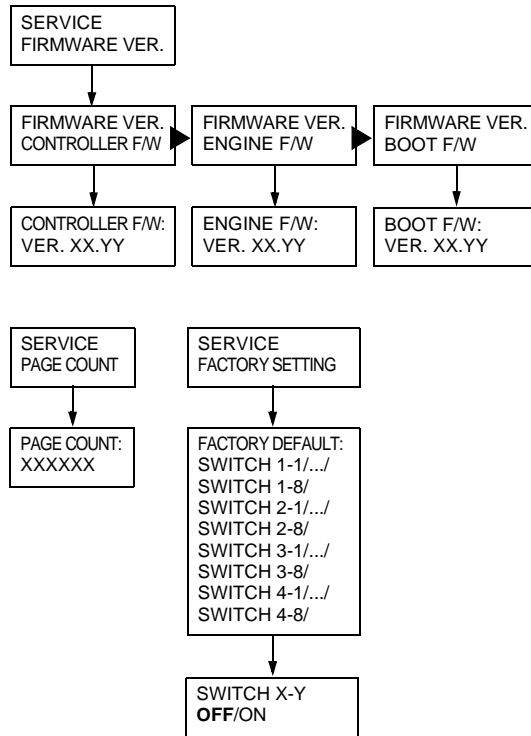

2-3. Contents of Panel Menu

(1) PRINT

Item	Description
STATISTIC PAGE	Print Statistic Page
CONFIGURATION	Print Configuration Page
FONT LIST	Print Font List
DEMO PAGE	Print Demonstration Page
REGISTRATION	Print Registration Page.
MENU MAP	Print Menu map.
DIRECTORY LIST	<ul style="list-style-type: none"> • Print Directory List for Hard Disk Drive. * Displayed when Hard Disk Drive is mounted.

- * Press and hold the ▲ key for several seconds when in READY to gain direct access to the "PRINT DEMO PAGE".
- * Internal pages are reduced or enlarged for the paper size (A3, A4, Letter, Ledger, Legal, B4, JIS, B5) installed in the "DEFAULT TRAY".

(2) PAPER

Item	Description
INPUT TRAY	Settings for the Paper Feed Tray. DEFAULT TRAY <ul style="list-style-type: none"> • Select the priority paper feed tray TRAY CHAIN <ul style="list-style-type: none"> • When ON is selected and paper runs out while printing, the printer automatically switches to another tray that holds the same paper size. TRAY 1 CONTROL <ul style="list-style-type: none"> • Select paper type for tray 1 (default media) • Specify whether to include Tray1 in group of trays selected by TRAY CHAIN.
DUPLEX	Select printing method when duplex unit is in use. OFF <ul style="list-style-type: none"> • One-sided printing SHORT EDGE <ul style="list-style-type: none"> • Two-sided, vertical printing in calendar style. LONG EDGE <ul style="list-style-type: none"> • Two-sided, vertical printing in book style. * Only displayed when the optional Duplex Unit is mounted.
COPIES	Specify number of copies.
COLLATE	Set the default settings. <ul style="list-style-type: none"> • When printing two or more copies, press ON for the printer to automatically print and sort. * Displayed only when the Option HDD is mounted.

(3) QUALITY

Item	Description
AIDC	<ul style="list-style-type: none"> • Press ON to automatically adjust the Correction Curve.
TRAY ALIGNMENT	<p>Fine tune the image write position on each tray.</p> <p>TOP ADJ NORMAL</p> <ul style="list-style-type: none"> • Adjust the upper margin for plain paper in each tray. <p>TOP ADJ THICK</p> <ul style="list-style-type: none"> • Adjust the upper margin for thick paper in each tray. <p>LEFT ADJUST</p> <ul style="list-style-type: none"> • Adjust the left margin for each tray. <p>LEFT ADJ DUPLEX</p> <ul style="list-style-type: none"> • Adjust the left margin for two-sided printing for each tray.

(4) INTERFACE

Item	Description
ETHERNET	<p>IP ADDRESS</p> <ul style="list-style-type: none"> • Set the IP address for the printer. <p>SUBNET MASK</p> <ul style="list-style-type: none"> • Set the subnet mask for the network. <p>GATEWAY</p> <ul style="list-style-type: none"> • Set the IP address when there is a router for the network. <p>DHCP/BOOTP</p> <ul style="list-style-type: none"> • Automatically obtains the IP address from the server and determine the correct settings when information is loaded from other networks. <p>HW ADDRESS</p> <ul style="list-style-type: none"> • Display the MAC address for Ethernet.
PARALLEL	<p>IO TIMEOUT</p> <ul style="list-style-type: none"> • Define the interval after which communication is stopped if communication has not occurred.

(5) SYS DEFAULT

Item	Description
LANGUAGE	<p>Selects the language for the Message Window.</p> <p>* The initial values will differ according to the destination.</p> <p>* Models for Japan: Japanese, Models for the US and Europe: ENGLISH</p>
ENERGY SAVER	<p>Sets the time for switching to Energy Saver mode when no print jobs are received or no operation is performed on the Control Panel. Starts Warm-up when a print job is transmitted during Energy Saver mode.</p> <p>SLEEP MODE</p> <ul style="list-style-type: none"> When "SLEEP MODE" is selected, switches to either DEEP SLEEP/LIGHT SLEEP/STANDBY MODE. In "STANDBY MODE" the temperature of the heating roller is lower than when in READY but higher than when in DEEP SLEEP/LIGHT SLEEP. When set to OFF, Energy Saver mode is not enabled. <p>SLEEP TIMER</p> <ul style="list-style-type: none"> Sets the time for changing to DEEP SLEEP/LIGHT SLEEP/STAND BY MODE. The default is 30 minutes. <p>DEEP SLEEP MENU</p> <ul style="list-style-type: none"> Only displays in "DEEP SLEEP" and defines the time period for switching to "DEEP SLEEP". Once the time set for "SLEEP TIMER" is exceeded and the current time is included in the time period that has been defined, the printer immediately goes into DEEP SLEEP. However, if the current time is not included in the time period that has been defined, it goes into LIGHT SLEEP and when the current time reaches the defined time, it goes into DEEP SLEEP.
BUZZER CONTROL	<p>ERROR BEEP</p> <ul style="list-style-type: none"> Sets whether to sound off the Buzzer when an error occurs. <p>KEY CLICK</p> <ul style="list-style-type: none"> Sets whether to produce a sound when a key is pressed on the control panel.
POSTSCRIPT	<p>JOB TIME OUT</p> <ul style="list-style-type: none"> Sets the WAIT TIME for time period after a print job is requested until a response is executed. <p>WAIT TIMEOUT</p> <ul style="list-style-type: none"> Determines whether to initiate a TIMEOUT when there is no data communication for a predetermined time period and the amount of time that elapses before going into TIMEOUT. (Does not TIMEOUT for 0 SECONDS) <p>ERROR REPORT</p> <ul style="list-style-type: none"> Determines whether to issue a PostScript errors.
CHANGE PASSWORD	<ul style="list-style-type: none"> Sets an access password to access INTERF ACE menu and SYS DEFAULT. The "0000" default means that no password is set.

Item	Description
HDD FORMAT	<ul style="list-style-type: none"> • Selects the region for formatting the HDD, and initiates formatting. * Only displays when the optional HDD is mounted.
CLOCK	<ul style="list-style-type: none"> • Sets the time and date. * The panel displays will differ according to the destination. * Models for Japan: YY.MM.DD, Models for the US: DD.MM.YY, Models for Europe: MM.DD.YY * YY: Year, MM: Month, DD: Day
AUTO CONTINUE	<ul style="list-style-type: none"> • If ON is selected, printing is performed even if the paper size in the print data differs from the paper size in the selected tray.
START PAGE	<ul style="list-style-type: none"> • If ON is selected, the Configuration Page is printed after the main power is turned on.
RESTORE DEFAULT	<p>NETWORK</p> <ul style="list-style-type: none"> • The INTERFACE setting restores the factory default settings. * The IO TIMEOUT does not restore the factory default settings. <p>RESTORE PRINTER</p> <ul style="list-style-type: none"> • The PAPER/QUALITY/SYS DEFAULT setting restores the factory default settings. * The TRAY ALIGNMENT in the QUALITY and the PASSWORD CHANGE in the SYS DEFAULT do not restore the factory default settings. <p>RESTORE ALL</p> <ul style="list-style-type: none"> • Restores all settings to the factory default settings. * The TRAY ALIGNMENT in the QUALITY, the PASSWORD CHANGE in the SYS DEFAULT, and the FACTORY SETTING in the SERVICE do not restore the factory default settings.

(6) SERVICE

Item	Description
FIRMWARE VER.	<p>CONTROLLER F/W</p> <ul style="list-style-type: none"> • Displays the CONTROLLER FIRMWARE Version. <p>ENGINE F/W</p> <ul style="list-style-type: none"> • Displays the ENGINE FIRMWARE Version. <p>BOOT F/W</p> <ul style="list-style-type: none"> • Displays the BOOT FIRMWARE Version.
PAGE COUNT	Displays total number of pages printed.
FACTORY SETTING	<p>SWITCH 1-3</p> <ul style="list-style-type: none"> • Color matching correction is not performed when "ON" is selected. The default value is "OFF". <p>SWITCH 2-2</p> <ul style="list-style-type: none"> • Upon selecting "ON", a warning message is displayed on the message window when the total number of printed pages reaches the operational life of the printer. The default value is "OFF". <p>Switch 4-1</p> <ul style="list-style-type: none"> • Selecting "OFF" displays the service call message. The default value is "ON". <p>SWITCH 4-3</p> <ul style="list-style-type: none"> • If "ON" is selected, warning messages related to the fuser unit and transfer belt unit will not be displayed. The default value is "OFF".

(7) PASSWORD PROTECTION

- In the "INTERFACE" menu or "SYS DEFAULT" menu, enter the password that was set on the, "SYS DEFAULT" menu.
- If the password was not changed on the "SYS DEFAULT" menu, then the "Enter Password" screen will not be displayed.
- Enter your password when accessing the "SERVICE" menu. The password cannot be changed for the "MQI7300".
- If the correct password is entered, the desired menu is accessed.
- If an incorrect password is entered, "WRONG PASSWORD!" displays for two seconds and the system returns to the Main Menu.

3. MAINTENANCE MODE

3-1. Setting the Maintenance Mode

NOTE

- *Ensure appropriate security for Maintenance Mode function setting procedures. Do not share with persons not involved with service tasks.*
-

<Procedure>

1. Confirm that the Initialize Screen displays.
2. Press the Continue key and Cancel key for 3 seconds.
3. The Maintenance Mode displays in the message window and the settings may be changed.

<Exiting>

- Turn the main power for the Printer OFF.

<Changing the Setting Values in Maintenance Mode Functions>

- Change the setting values using the ◀ key and ▶ key.
- Select the setting values using the Menu/Select key.

3-2. Summary of the Maintenance Mode

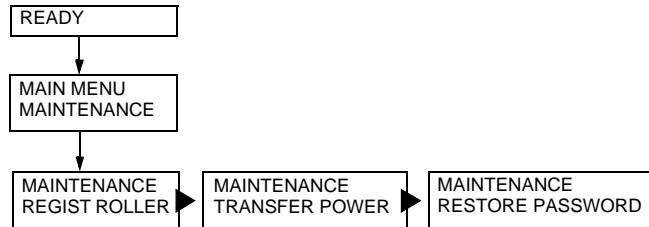

3-3. Maintenance Menu

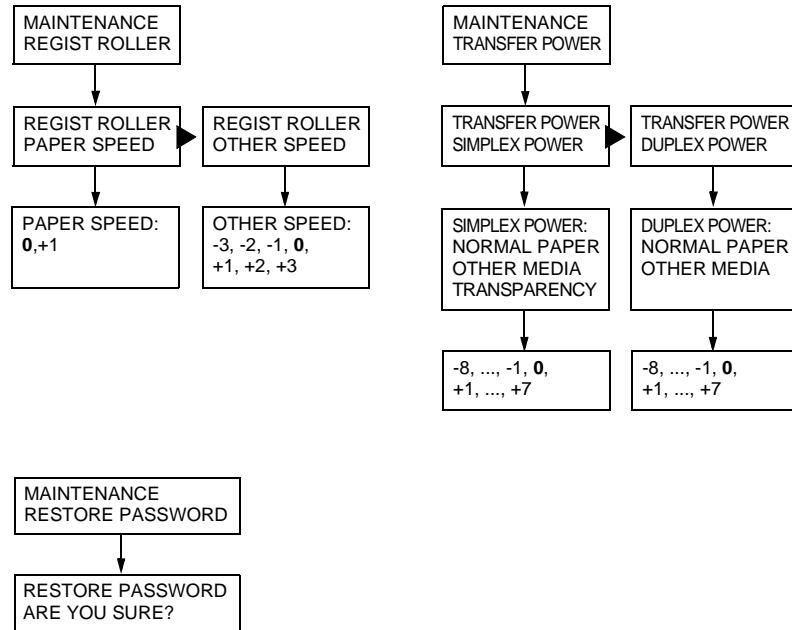

DEFAULT IS UPPERCASE

*1: Displayed when the Add-on Cassette is mounted.

*2: Displayed when the Duplex Unit is mounted.

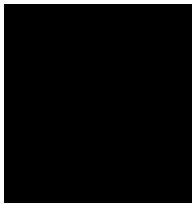

3-4. Contents of Maintenance Mode

(1) REGIST ROLLER

Item	Purpose	SETTINGS/CAUTIONS
PAPER SPEED	This changes the speed of the paper feed drive motor when printing with normal paper.	<ul style="list-style-type: none"> The setting value is 0 or +1. Select with the ◀ key or ▶ key and set using the Menu/Select key.
OTHER SPEED	This changes the speed of the paper feed drive motor when printing with thick paper.	<ul style="list-style-type: none"> The setting range is -3 through +3 Select with the ◀ key or ▶ key and set using the Menu/Select key.

(2) TRANSFER POWER

Item	Purpose	SETTINGS/CAUTIONS
SIMPLEX POWER	When an image problem (image transfer failure, excess images) occurs due to environmental conditions or paper type, adjust the 2nd Image Transfer Current.	<p>Normal Paper</p> <ul style="list-style-type: none"> The settings range is -8 through +7 Select with the ◀ key or ▶ key and set with the Menu/Select key. <p>Other Paper</p> <ul style="list-style-type: none"> The settings range is -8 through +7 Select with the ◀ key or ▶ key and set with the Menu/Select key. <p>Transparency</p> <ul style="list-style-type: none"> The settings range is -8 through +7 Select with the ◀ key or ▶ key and set with the Menu/Select key.
DUPLEX POWER	Adjusts the 2nd Image Transfer Current during two-sided printing.	<p>Normal Paper</p> <ul style="list-style-type: none"> The settings range is -8 through +7 Select with the ◀ key or ▶ key and set with the Menu/Select key. <p>Other media</p> <ul style="list-style-type: none"> The settings range is -8 through +7 Select with the ◀ key or ▶ key and set with the Menu/Select key.

(3) RESTORE PASSWORD

Item	Purpose	SETTINGS/CAUTIONS
RESTORE PASSWORD	Restore user password to "0000". This is useful when forget password.	<p>ARE YOU SURE?.</p> <ul style="list-style-type: none"> Excute "RESTORE PASSWORD" with the Menu/Select key.

4. UPDATE FIRMWARE

4-1. Update using IEEE-1284 Parallel Cable

NOTE

- Ensure appropriate security for Tech. Rep. mode function settings. Do not share with any persons not involved in service tasks.
-

1. Turn OFF the Power Switch.
2. Connect the Controller Board and the Host Computer with an IEEE-1284 parallel cable.
3. Turn ON the printer main switch while holding the ▲ key.
4. When "INITIALIZING" displays, release the ▲ key.

INITIALIZING

4134D511AB

5. Wait until "FIRMAWARE UPDATE WAIT" is displayed in the control panel.

FIRMAWARE UPDATE
WAIT

C4134S031CA

6. Start the Host Computer and initiate a DOS prompt or Command prompt.
7. Input the following and press the Enter key.
(Ex.) When the firmware data is located in the C drive
C:\>copy /b xxxx.xxx prn:

NOTE

- DO NOT turn the printer power OFF during firmware overwrite.
-

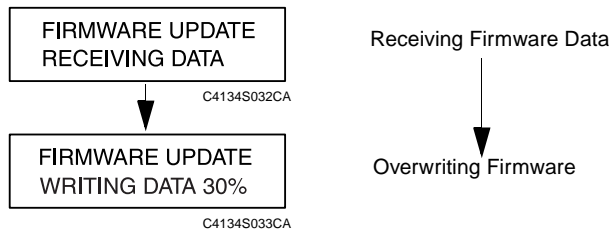

8. The following message displays on the Control Panel to confirm Firmware Update completion.

FIRMWARE UPDATE
COMPLETE

C4134S035CA

TURN OFF THE
PRINTER TO EXIT

4134S515AA

9. Turn the Main Switch on the Printer ON/OFF.

4-2. Network Cable (FTP) Update

NOTE

- Ensure appropriate security for Tech. Rep. mode function setting procedures. Do not share with any persons not involved in service tasks.

1. Turns the Main Switch on the Printer OFF.
2. Connect the Controller Board to the Host Computer with a Network Cable.
3. Turn the Main Switch ON while holding the ▲ key.
4. When "INITIALIZING" displays, release the ▲ key.

INITIALIZING

4134D511AB

5. Wait until "FIRMAWARE UPDATE WAIT" is displayed in the control panel.

FIRMAWARE UPDATE
WAIT

C4134S031CA

6. Start the Host Computer and initiate a DOS prompt or Command prompt.
7. Enter "ftp" and press the Enter key.
C:\>ftp
8. Enter "open" and press the Enter key.
ftp>open
9. Enter the IP address for the Printer and press the Enter key.
To XXX.XXX.XXX.XXX
10. Enter "binary" and press the Enter key.
User (XXX.XXX.XXX.XXX:(none)):binary
11. Enter "put xxxx.xxx" and press the Enter key.

NOTE

- DO NOT turn the printer power OFF during firmware overwrite.

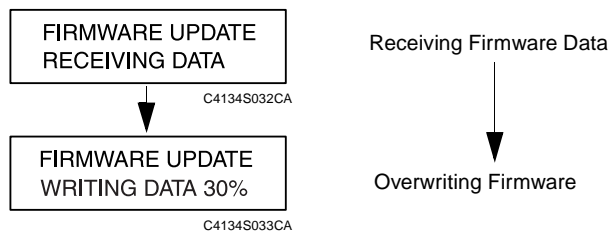

12. The following message displays on the Control Panel to confirm Firmware Update completion.

FIRMWARE UPDATE
COMPLETE

C4134S035CA

TURN OFF THE
PRINTER TO EXIT

4134S515AA

13. Turn the Main Switch on the Printer ON/OFF.

4-3. When Update Fails

- When UPDATE fails, the following message displays on the Control Panel.

FIRMWARE UPDATE
WRITING ERROR

C4134S036CA

1. Turn OFF the Main Switch on the Printer.
2. Perform Firmware Update again.



TROUBLESHOOTING

1. INTRODUCTION

- Information required for troubleshooting and steps that must be performed are described in this Chapter.

1-1. Checking the electrical components

- If a paper misfeed or malfunction occurs, perform the following operation to check the condition of the electrical components.

(1) Sensor

Step	Check Item	Result	Action
1	Does the input signal of the master board change when the sensor light is interrupted? (H → L, L → H)	NO	Replace the sensor.
		YES	Replace the control board.

(2) Switch

Step	Check Item	Result	Action
1	Does the input signal (NO) of the master board change from L to H when the switch is turned on?	NO	Replace the switch.
		YES	Replace the control board.

4025T523AA

(3) Solenoid

Step	Check Item	Result	Action
1	Does the output signal of the master board change from H to L when the solenoid is turned on?	NO	Replace the control board.
		YES	Replace the solenoid.

4025T522AA

(4) Clutch

Step	Check Item	Result	Action
1	Does the output signal of the master board change from H to L when the clutch is activated?	NO	Replace the control board.
		YES	Replace the clutch.

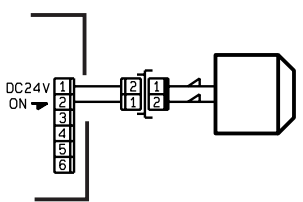

4025T528AA

(5) Motor

Step	Check Item	Result	Action
1	Does the LOCK signal switch to H when the machine goes into standby?	NO	Replace the control board. Replace the motor.
2	Does the REM signal of the master board change from H to L when the motor is turned on?	YES	Replace the motor.
		NO	Replace the control board.

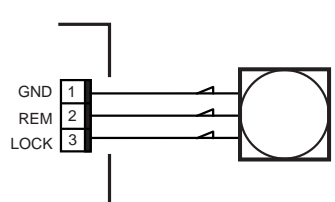

4025T526AA

Step	Check Item	Result	Action
1	Does the input signal of the master board change from H to L when the clutch is activated? (Input signals differ according to the direction of rotation)	YES	Replace the motor.
		NO	Replace the control board.

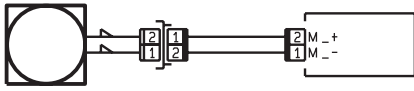

4025T525AA

Step	Check Item	Result	Action
1	Are the relay connector of the motor and the print jack on the master board correctly connected?	YES	Replace the motor or the control board.
		NO	Connect the connector or the print jack.

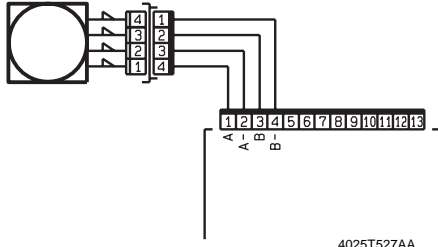

4025T527AA

1-2. System Control Block Diagram

- Understanding the system control block diagram will help make the troubleshooting procedures for paper misfeeds, malfunctions, and image problems easier.

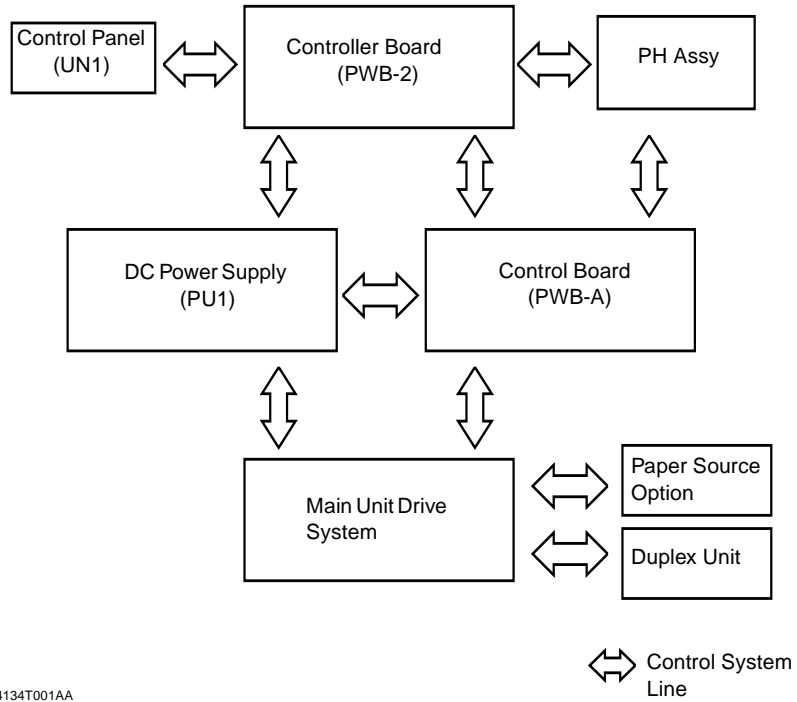

2. JAM

2-1. Initial Check Items

- When a paper misfeed occurs, first make checks of the following initial check items.

Check Item	Action
Does paper meet product specifications?	Change paper.
Is paper curled, wavy, or damp.	Change paper. Instruct user in correct paper storage.
Is a foreign object present along the paper path, or is the paper path deformed or worn?	Clean or change the paper path.
Are the Paper Separator Fingers dirty, deformed, or worn?	Change Fuser Unit.
Are rolls/rollers dirty, deformed, or worn?	Clean or change the defective roll/roller.
Are the Edge Guides and Trailing Edge Stop at correct position to accommodate paper?	Set as necessary.
Are actuators found operational as checked for correct operation?	Correct or change the defective actuator.

2-2. Misfeed Display

- When a paper misfeed occurs a message is displayed on the Control Panel.

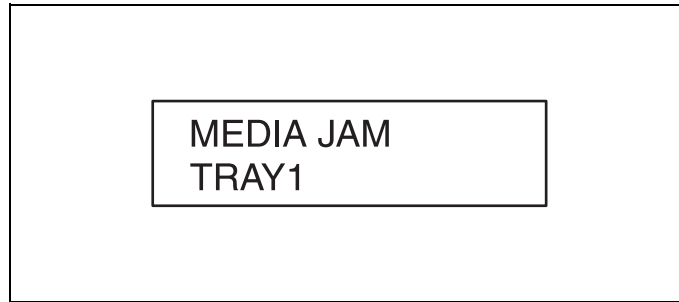

C4134S037CA

Display	Misfeed Location	Action
MEDIA JAM TRAY1	1st Drawer Paper Take-Up Section	☞ T-9
MEDIA JAM TRAY2	2nd Drawer Paper Take-Up Section	☞ T-10
MEDIA JAM TRAY3	3rd Drawer Paper Take-Up Section (Optional)	☞ T-11
MEDIA JAM TRAY4	4th Drawer Paper Take-Up Section (Optional)	☞ T-11
MEDIA JAM MANUAL TRAY	Manual Bypass Paper Take-Up Unit (Optional)	☞ T-12
MEDIA JAM DUPLEX1	Duplex Paper Take-Up Section (Optional)	☞ T-13
MEDIA JAM DUPLEX2	(Duplex Paper Transport Section (Optional)	☞ T-14
MEDIA JAM VERTICAL TRANS	Vertical Transport	☞ T-15
MEDIA JAM SECOND TRANS	2nd Image Transfer	☞ T-17
EDIA JAM FUSER/EXIT	Fusing/Exit	☞ T-18
MEDIA JAM FUSER/EXIT/DUP.	Fusing/Exit	☞ T-18

2-3. Misfeed Detecting Sensor Layout

- When the Duplex Unit, Manual Bypass Unit and 3rd and 4th Drawers have been mounted.

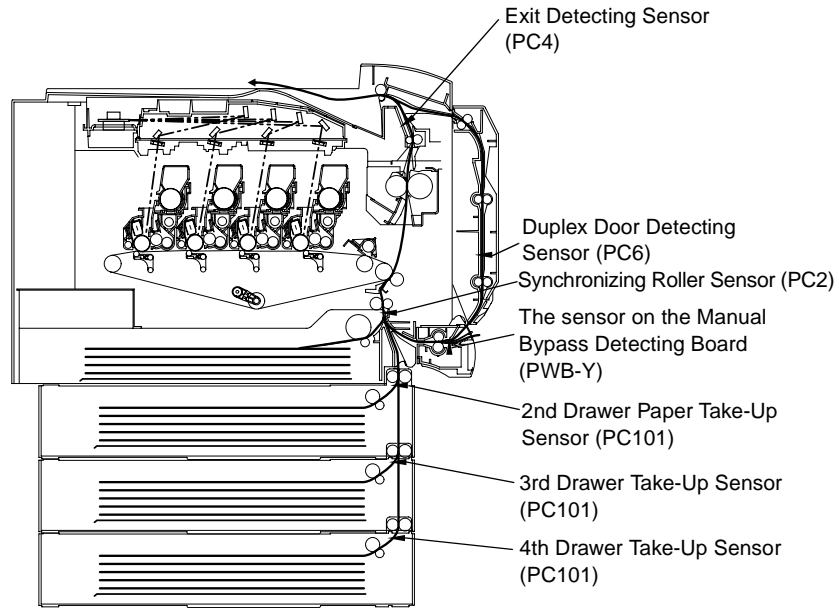

4134T002AA

2-4. Misfeed Detection Timing/Troubleshooting Procedures

(1) Misfeed in the 1st Drawer Paper Take-Up Section

<Detection Timing>

Type	Description
Paper Take-Up Section Misfeed Detected	If the leading edge of the paper does not block the synchronizing sensor (PC2) after the paper begins to feed.

<Action>

Relevant Electrical Parts	
Synchronizing Roller Sensor (PC2) Paper Take-Up Drive Motor (M1)	Control Board (PWB-A)

Step	Action	Ref. Page	WIRING DIAGRAM	
			Control Signal	(Location) (Electrical Parts)
1	Initial Check Items	T-6	—	—
2	PC2 Operation Check	T-1	PWB-A CNPE-A-6 (ON)	13-H
3	M1 Operation Check	T-3	PWB-A CNSTM-A-5 to 8 (Pulse Output)	11-G
4	Change PWB-A.	—	—	—

(2) 2nd Drawer Paper Misfeed

<Detection Timing>

Type	Description
Paper Take-Up Section Misfeed Detected	If the 2nd Drawer Paper Take-Up sensor (PC101) is not blocked after a predetermined period of time lapses once the paper begins to feed.
2nd Drawer Detection of paper left	If the 2nd Drawer Paper Take-Up Sensor (PC101) is blocked when the Power Switch is turned ON, a door or cover is opened and closed, or a misfeed or malfunction is reset.

<Action>

Relevant Electrical Parts	
2nd Drawer Paper Take-Up Sensor (PC101) 2nd Drawer Paper Take-Up Clutch (CL101) 2nd Drawer Paper Take-Up Motor (M101)	2nd Drawer Control Board (PWB-A)

Step	Action	Ref. Page	WIRING DIAGRAM	
			Control Signal	(Location) (Electrical Parts)
1	Initial Check Items	T-6	—	—
2	PC101 Operation Check	T-1	PWB-A PJ3A-A-3 (ON)	20-C
3	CL101 Operation Check	T-3	PWB-A PJ3A-B-14 (ON)	20-E
4	M101 Operation check	T-3	PWB-A PJ5A-1 to 4 (Pulse Output)	20-A
5	Change PWB-A.	—	—	—

(3) 3rd and 4th Drawers Paper Take-Up Section Misfeed (Optional)

<Detection Timing>

Type	Description
Paper Take-Up Section Misfeed Detected	If the 3rd or 4th Drawer Paper Take-Up Sensor (PC101) is not blocked after a predetermined period of time lapses once the paper begins to feed.
3rd, 4th Drawer Detection of paper left	If the 3rd or 4th Drawer Paper Take-Up Sensor (PC101) is blocked when the Power Switch is turned ON, a door or cover is opened and closed, or a misfeed or malfunction is reset.

<Action>

Relevant Electrical Parts	
3rd Drawer Paper Take-Up Sensor (PC101) 3rd Drawer Paper Take-Up Clutch (CL101) 3rd Drawer Paper Take-Up Motor (M101) 4thDrawer Paper Take-Up Sensor (PC101) 4thDrawer Paper Take-Up Clutch (CL101) 4th Drawer Paper Take-Up Motor (M101)	3rd Drawer Control Board (PWB-A) 4th Drawer Control Board (PWB-A)

Step	Action	Ref. Page	WIRING DIAGRAM	
			Control Signal	(Location) (Electrical Parts)
1	Initial Check Items	T-6	—	—
2	PC101 Operation Check	T-1	PWB-A PJ3A-A-3 (ON)	20-C
3	CL101 Operation Check	T-3	PWB-A PJ3A-B-14 (ON)	20-E
4	M101 Operation check	T-3	PWB-A PJ5A-1 to 4 (Pulse Output)	20-A
5	Change PWB-A.	—	—	—

(4) Manual Bypass Take-Up Misfeed (Optional)

<Detection Timing>

Type	Description
Manual bypass paper take-up failure detection	If the Synchronizing Roller Sensor (PC2) is not blocked after a predetermined period of time lapses once the paper begins to feed.
Detection of paper left in Manual Bypass	If the Manual Feed Paper Take-Up Sensor (PWB-Y) is blocked when the Power Switch is turned ON, a door or cover is opened and closed, or a misfeed or malfunction is reset.

<Action>

Relevant Electrical Parts	
Synchronizing Sensor (PC2) Manual Bypass Paper Take-Up Drive Motor (M11)	Manual Bypass Detecting Board (PWB-Y) Control Board (PWB-A)

Step	Action	Ref. Page	WIRING DIAGRAM	
			Control Signal	(Location) (Electrical Parts)
1	Initial Check Items	T-6	—	—
2	PC2 Operation Check	T-1	PWB-A CNPE-A-6 (ON)	12-B
3	M11 Operation check	T-3	PWB-Y PJ2-Y-1 to 4 (Pulse Output)	22-F
4	Change PWB-Y.	—	—	—
5	Change PWB-A.	—	—	—

(5) Duplex Paper Take-up Section Misfeed (Optional)

<Detection Timing>

Type	Description
Duplex Paper Take-Up Section Misfeed Detected	If the leading edge of the paper does not block the Synchronizing Sensor (PC2) after a predetermined period of time lapses once the paper begins to feed again.
Duplex Paper Take-Up Section Detection of paper left	If the Synchronizing Roller Sensor (PC2) is blocked when the Power Switch is turned ON, a door or cover is opened and closed, or a misfeed or malfunction is reset.

<Action>

Relevant Electrical Parts	
Duplex Door Detecting Sensor (PC6) Duplex Unit Drive Motor (M10)	Duplex Control Board (PWB-X) Manual Bypass Detecting Board (PWB-Y) Control Board (PWB-A)

Step	Action	Ref. Page	WIRING DIAGRAM	
			Control Signal	(Location) (Electrical Parts)
1	Initial Check Items	T-6	—	—
2	PC6 Operation Check	T-1	PWB-X PJ3-X-2(ON)	22-H
3	M10 Operation Check	T-3	PWB-X PJ2-X-1 to 4 (Pulse Output)	22-H
4	Change PWB-X.	—	—	—
5	Change PWB-Y.	—	—	—
6	Change PWB-A.	—	—	—

(6) Duplex Transport Section Misfeed (Optional)

<Detection Timing>

Type	Description
Duplex Unit transport Misfeed Detected	Even if after the paper has blocked the Duplex Door Detecting Sensor (PC6), the Duplex Door Detecting Sensor (PC6) is not blocked after a predetermined period of time lapses.
	Even if after the paper has blocked the Duplex Door Detecting Sensor (PC6) the sensor on the Manual Bypass Detecting Board (PWB-Y) is not blocked after a predetermined period of time lapses.
Duplex Unit transport Detection of paper left	If the duplex unit transport sensor (PC6) is interrupted when the machine is turned on, doors and covers are opened, then closed, and paper misfeeds and malfunctions are corrected

<Action>

Relevant Electrical Parts	
Duplex Door Detecting Sensor (PC6) Duplex Unit Drive Motor (M10)	Duplex Control Board (PWB-A) Manual Bypass Detecting Board (PWB-Y) Control Board (PWB-A)

Step	Action	Ref. Page	WIRING DIAGRAM	
			Control Signal	(Location) (Electrical Parts)
1	Initial Check Items	T-6	—	—
2	PC6 Operation Check	T-1	PWB-X PJ3-X-2(ON)	22-H
3	M10 Operation Check	T-3	PWB-X PJ2-X-1 to 4 (Pulse Output)	22-H
4	Change PWB-X.	—	—	—
5	Change PWB-Y.	—	—	—
6	Change PWB-A.	—	—	—

(7) Vertical Transport Misfeed

<Detection Timing>

Type	Description
Vertical Transport Misfeed Detected	2nd Drawer The Synchronizing Roller Sensor (PC2) is not blocked even after the lapse of a given period of time after the 2nd Drawer Paper Take-Up Sensor (PC101) has been blocked by the paper.
	1st Drawer The 2nd Drawer Paper Take-Up Sensor (PC101) is not blocked even after the lapse of a given period of time after the 3rd Drawer Paper Take-Up Sensor (PC101) has been blocked by the paper.
	4th Drawer The 3rd Drawer Paper Take-Up Sensor (PC101) is not blocked even after the lapse of a given period of time after the 4th Drawer Paper Take-Up Sensor (PC101) has been blocked by the paper.

<Action>

- 2nd Drawer

Relevant Electrical Parts	
Synchronizing Roller Sensor (PC2)	2nd Drawer Paper Take-Up Motor (M101)
2nd Drawer Paper Take-Up Sensor (PC101)	2nd Drawer Control Board (PWB-A)
2nd Drawer Paper Take-Up Clutch (CL101)	

Step	Action	Ref. Page	WIRING DIAGRAM	
			Control Signal	(Location) (Electrical Parts)
1	Initial Check Items	T-6	—	—
2	PC2 Operation Check	T-1	PWB-A CNPE-A-6 (ON)	12-B
3	PC101 Operation Check	T-1	PWB-A PJ3A-1A (ON)	20-C
4	CL101 Operation Check	T-3	PWB-A PJ3A-14B (ON)	20-E
5	M101 Operation Check	T-3	PWB-A PJ5A-1 to 4 (Pulse Output)	20-A
6	Change PWB-A.	—	—	—

- 3rd, 4thDrawer (optional)

Relevant Electrical Parts	
3rd Drawer Paper Take-Up Sensor (PC101)	4th Drawer Paper Take-Up Sensor (PC101)
3rd Drawer Paper Take-Up Clutch (CL101)	4thDrawer Paper Take-Up Clutch (CL101)
3rd Drawer Paper Take-Up Motor (M101)	4th Drawer Paper Take-Up Motor (M101)
3rd Drawer Control Board (PWB-A)	4th Drawer Control Board (PWB-A)

Step	Action	Ref. Page	WIRING DIAGRAM	
			Control Signal	(Location) (Electrical Parts)
1	Initial Check Items	T-6	—	—
2	PC101 Operation Check	T-1	PWB-A PJ3A-1A (ON)	20-C
3	CL101 Operation Check	T-3	PWB-A PJ3A-14B (ON)	20-E
4	M101 Operation Check	T-3	PWB-A PJ5A-1 to 4 (Pulse Output)	20-A
5	Change PWB-A.	—	—	—

(8) 2nd Image Transfer Misfeed

<Detection Timing>

Type	Description
2nd Image Transfer misfeed detection	The Synchronizing Roller Sensor (PC2) is not blocked even after a given period of time after the Synchronizing Roller Sensor (PC2) has been blocked by the paper.
	The Exit Sensor (PC4) is not blocked even after the lapse of a given period of time after the Synchronizing Roller Sensor (PC2) has been blocked by the paper.
2nd Image Transfer Detection of paper left.	If the Synchronizing Roller Sensor (PC2) is blocked when the Power Switch is turned ON, a door or cover is opened and closed, or a misfeed or malfunction is reset.
	If the OHP Detecting Sensor (PC1) is blocked when the Power Switch is turned ON, a door or cover is opened and closed, or a misfeed or malfunction is reset.

<Action>

Relevant Electrical Parts	
Synchronizing Roller Sensor (PC2) Exit Detection Sensor (PC4) OHP Detecting Sensor (PC1)	Control Board (PWB-A)

Step	Action	Ref. Page	WIRING DIAGRAM	
			Control Signal	(Location) (Electrical Parts)
1	Initial Check Items	T-6	—	—
2	P2 Operation Check	T-1	PWB-A CNPE-A-6 (ON)	12-B
3	PC4 Operation Check	T-1	PWB-A CNPO-A-6 (ON)	6-H
4	PC1 Operation Check	T-1	PWB-A CNPE-A-8 (ON)	12-B
5	Change PWB-A.	—	—	—

(9) Fusing/Exit Misfeed

<Detection Timing>

Type	Description
Fusing/Exit Misfeed Detected	The Exit Sensor (PC4) is not blocked even after the lapse of a given period of time after the Exit Sensor (PC4) has been blocked by the paper.
	The Duplex Door Detecting Sensor (PC6) is not blocked even after the lapse of a given time period after the Exit Sensor (PC4) has been blocked by the paper during switchback.
Fusing/Exit Detection of paper left	If the Exit Sensor (PC4) is blocked when the Power Switch is turned ON, a door or cover is opened and closed, or a misfeed or malfunction is reset.

<Action>

Relevant Electrical Parts	
Exit Sensor (PC4) Duplex Door Detecting Sensor (PC6)	Control Board (PWB-A)

Step	Action	Ref. Page	WIRING DIAGRAM	
			Control Signal	(Location) (Electrical Parts)
1	Initial Check Items	T-6	—	—
2	PC4 Operation Check	T-1	PWB-A CNPO-A-6 (ON)	6-H
3	PC6 Operation Check	T-1	PWB-X PJ3-X-2 (ON)	22-H
4	Change PWB-A.	—	—	—

3. MALFUNCTIONS

- The printer CPU performs a self-diagnostics function that, on detecting a malfunction, gives the corresponding malfunction code and maintenance call mark on the Touch Panel.

SERVICE CALL3047
PH FUN

C4134S029CA

3-1. Malfunction Codes

Code	Name of Malfunction	Description	Reference page
C15 C23 C24	BOOT FLASH ROM	Boot Flash ROM Access Failure	☞ T-21
C26 C27	SMARTMEDIA	SMARTMEDIA Write/Read Failure	☞ T-21
C50	HDD ERROR	HDD Access Failure	☞ T-22
C28	CALIBRATION LSI	LSI Calibration Failure	☞ T-22
C02 C03	RAM ERROR	RAM Access Failure	☞ T-23
C22	EEPROM ERROR	EEPROM Access Failure	☞ T-23
C13	H/W ADDRESS	MAC Address Error	☞ T-24
C51	HDD DISK FULL	HDD Data Capacity Full	☞ T-24
13C8	T-BELT DETECT	New Transfer Belt Unit Resetting Failure	☞ T-25
13CA	FUSER DETECT	New Fuser Unit Resetting Failure	☞ T-25
13D0	EEPROM1	EEPROM Failure (Main Unit)	☞ T-26
13D5	EEPROM2	EEPROM Failure (PH Unit)	☞ T-26
13E2	FLASH WRITE	Flash ROM Write Failure	☞ T-27
13E3	FLASH DEVICE	Flash ROM Device Failure	☞ T-27
0010	PROC MOTOR COLOR	PU Drive Motor C/M/Y Failure	☞ T-28
0017	PROC MOTOR BLACK	PU Drive Motor Bk Failure	☞ T-28
3046	FUSER FAN	Fusing Cooling Fan Motor Failure	☞ T-29
3047	PHFAN	PH Cooling Fan Motor Failure	☞ T-29
3048	COOLING FAN	PU Cooling Fan Motor Failure	☞ T-29
0040	SUCTION FAN	Suction Fan Motor Failure	☞ T-29
004C	OZONE FAN	Ozone Fan Motor Failure	☞ T-29
004E	POWER FAN	Power Supply Cooling Fan Motor Failure	☞ T-29

0094	XFER DETACH 2	2nd Image Transfer Roller Pressure/ Retraction failure	☞ T-32
0096	XFER DETACH 1	Image Transfer Belt Pressure/Retraction Failure	☞ T-32
0060	FUSER MOTOR	Fusing Drive Motor Failure	☞ T-33
3020	PICK MOTOR	Paper Take-Up Drive Motor Failure	☞ T-33
3021	REGIST MOTOR	Transport Drive Motor Failure	☞ T-33
3022	DUPLEX MOTOR	Duplex Unit Drive Motor Failure	☞ T-33
3023	MANUAL MOTOR	Manual Bypass Paper Take-Up Drive Motor Failure	☞ T-33
0250	POWER SUPPLY	Power Supply (24 V) Failure	☞ T-35
0300	POLYGON MOTOR	Polygon Motor Failure	☞ T-36
0310	LASER ERROR	LASER ERROR	☞ T-36
0500	FUSER ERROR 0500	Heating Roller Warm-Up Error	☞ T-37
0501	FUSER ERROR 0501	Fusing Pressure Roller Warm-Up Error	☞ T-37
0510	FUSER ERROR 0510	Heating Roller Abnormally low temperature	☞ T-37
0511	FUSER ERROR 0511	Fusing Pressure Roller abnormally low temperature	☞ T-37
0520	FUSER ERROR 0520	Heating Roller abnormally high temperature	☞ T-37
0521	FUSER ERROR 0521	Fusing Pressure Roller abnormally high temperature	☞ T-37
FFFF	I/F COMM ERROR	Main Unit I/F Communication Failure	☞ T-38

3-2. Malfunction Detection Timing and Troubleshooting Procedure

(1) C15, C23, C24: Boot Flash ROM Access Failure

<Detection Timing>

Malfunction Code	Description
C15 C23 C24	When Boot Flash ROM Read/Write cannot be performed.

<Action>

Relevant Electrical Parts
Controller Board (PWB-Z)

Step	Action	Ref. Page	WIRING DIAGRAM	
			Control Signal	(Location) (Electrical Parts)
1	Change PWB-Z	—	—	—

(2) C26, C27: SMARTMEDIA Write/Read Failure

<Detection Timing>

Malfunction Code	Description
C26 C27	When the SMARTMEDIA card read/write cannot be performed.

<Action>

Relevant Electrical Parts
Controller Board (PWB-Z) SMARTMEDIA Card

Step	Action	Ref. Page	WIRING DIAGRAM	
			Control Signal	(Location) (Electrical Parts)
1	Change the SMARTMEDIA card.	—	—	—
2	Change PWB-Z.	—	—	—
3	Change the PWB-Z and SMARTMEDIA card as a set.	—	—	—

(3) C50: HDD Access Failure

<Detection Timing>

Malfunction Code	Description
C50	When the Hard Disk and Controller Board (PWB-Z) cannot communicate. Data transfer from the hard disk is faulty.

<Action>

Relevant Electrical Parts	
Hard Disk	Controller Board (PWB-Z)

Step	Action	Ref. Page	WIRING DIAGRAM	
			Control Signal	(Location) (Electrical Parts)
1	Reinstall the hard disk.	—	—	—
2	Change Hard Disk.	—	—	—
3	Change PWB-Z.	—	—	—

(4) C28: LSI Calibration Failure

<Detection Timing>

Malfunction Code	Description
C28	When calibration cannot be executed due to LSI Calibration Failure.

<Action>

Relevant Electrical Parts	
Controller Board (PWB-Z)	

Step	Action	Ref. Page	WIRING DIAGRAM	
			Control Signal	(Location) (Electrical Parts)
1	Change PWB-Z.	—	—	—

(5) C02, C03: RAM Access Failure

<Detection Timing>

Malfunction Code	Description
C02 C03	When the SDRAM DIMM and Controller Board (PWB-Z) cannot communicate.

<Action>

Relevant Electrical Parts	
SDRAM DIMM	Controller Board (PWB-Z)

Step	Action	Ref. Page	WIRING DIAGRAM	
			Control Signal	(Location) (Electrical Parts)
1	Change SDRAM DIMM.	—	—	—
2	Change PWB-Z.	—	—	—

(6) C22: EEPROM Access Failure

<Detection Timing>

Malfunction Code	Description
C22	When EEPROM and Controller Board (PWB-Z) cannot communicate.

<Action>

Relevant Electrical Parts	
Controller Board (PWB-Z)	

Step	Action	Ref. Page	WIRING DIAGRAM	
			Control Signal	(Location) (Electrical Parts)
1	Change PWB-Z.	—	—	—

(7) C13: MAC Address Error

<Detection Timing>

Malfunction Code	Description
C13	MAC Address is determined as incorrect.

<Action>

Relevant Electrical Parts
Controller Board (PWB-Z)

Step	Action	Ref. Page	WIRING DIAGRAM	
			Control Signal	(Location) (Electrical Parts)
1	Change PWB-IO.	—	—	—

(8) C51: HDD Data Capacity Full

<Detection Timing>

Malfunction Code	Description
C51	When there is not enough memory capacity in the Hard Disk to save the data.

<Action>

Relevant Electrical Parts
Hard Disk

Step	Action	Ref. Page	WIRING DIAGRAM	
			Control Signal	(Location) (Electrical Parts)
1	Deletes unwanted data on the Hard Disk.	—	—	—

(9) 13C8: New Transfer Belt Unit resetting failure

<Detection Timing>

Malfunction Code	Description
13C8	A new installation is not cancelled when a new Transfer Belt Unit is installed.

<Action>

Relevant Electrical Parts
Control Board (PWB-A)

Step	Action	Ref. Page	WIRING DIAGRAM	
			Control Signal	(Location) (Electrical Parts)
1	Reinstall the unit.	—	—	—
2	Change PWB-A.	—	—	—

(10) 13CA: New Fuser Unit resetting failure

<Detection Timing>

Malfunction Code	Description
13CA	A new installation is not cancelled when a new Fuser Unit is installed.

<Action>

Relevant Electrical Parts
Control Board (PWB-A)

Step	Action	Ref. Page	WIRING DIAGRAM	
			Control Signal	(Location) (Electrical Parts)
1	Reinstall the unit.	—	—	—
2	Change PWB-A.	—	—	—

(11) 13D0: EEPROM Failure (Main Unit)

<Detection Timing>

Malfunction Code	Description
13D0	When a write error occurs while checking EEPROM in the Main Unit.

<Action>

Relevant Electrical Parts
Control Board (PWB-A)

Step	Action	Ref. Page	WIRING DIAGRAM	
			Control Signal	(Location) (Electrical Parts)
1	Change PWB-A.	—	—	—

(12) 13D5: EEPROM Failure (PH Unit)

<Detection Timing>

Malfunction Code	Description
13D5	The printer does not become ready even after the lapse of a predetermined period of time after PH EEPROM access control has been executed when the power is turned ON.

<Action>

Relevant Electrical Parts
PH Unit Control Board (PWB-A)

Step	Action	Ref. Page	WIRING DIAGRAM	
			Control Signal	(Location) (Electrical Parts)
1	Check the PH connector for proper connection and correct as necessary.	—	—	—
2	Change PH unit.	—	—	—
3	Change PWB-A.	—	—	—

(13) 13E2: Flash ROM Write Failure

<Detection Timing>

Malfunction Code	Description
13E2	When the check sum value for the data transferred and the check sum value obtained when the device is read after writing is complete do not match.

<Action>

Relevant Electrical Parts
Control Board (PWB-A)

Step	Action	Ref. Page	WIRING DIAGRAM	
			Control Signal	(Location) (Electrical Parts)
1	Change PWB-A.	—	—	—

(14) 13E3: Flash ROM Device Failure

<Detection Timing>

Malfunction Code	Description
13E3	<ul style="list-style-type: none"> • When TIMEOUT occurs when flash is erased. • When TIMEOUT occurs for the Write function.

<Action>

Relevant Electrical Parts
Control Board (PWB-A)

Step	Action	Ref. Page	WIRING DIAGRAM	
			Control Signal	(Location) (Electrical Parts)
1	Change PWB-A.	—	—	—

(15) 0010: PU Drive Motor C/M/Y Failure

(16) 0017: PU Drive Motor Bk Failure

<Detection Timing>

Malfunction Code	Description
0010	<ul style="list-style-type: none"> The printer does not become ready even after the lapse of a predetermined period of time when the motor is turned ON. When the printer moves out of the ready state even after the lapse of a predetermined period of time while the motor is rotating.
0017	<ul style="list-style-type: none"> The printer does not become ready even after the lapse of a predetermined period of time when the motor is turned ON. When the printer moves out of the ready state even after the lapse of a predetermined period of time while the motor is rotating.

<Action>

Relevant Electrical Parts	
PU Drive Motor C/M/Y (M4) PU Drive Motor Bk (M5)	Control Board (PWB-A)

* 0010

Step	Action	Ref. Page	WIRING DIAGRAM	
			Control Signal	(Location) (Electrical Parts)
1	Check the motor connector for proper connection and correct as necessary.	—	—	—
2	Check Motor for proper drive coupling and correct as necessary.	—	—	—
3	M4 Operation Check	T-3	PWB-A CNPM-A-5A (REM)	9-C
4	Change PWB-A.	—	—	—

* 0017

Step	Action	Ref. Page	WIRING DIAGRAM	
			Control Signal	(Location) (Electrical Parts)
1	Check the motor connector for proper connection and correct as necessary.	—	—	—
2	Check the motor for proper drive coupling and correct as necessary.	—	—	—
3	M5 Operation Check	T-3	PWB-A CNPM-A-5B (REM)	12-H
4	Change PWB-A.	—	—	—

- (17) **3046: Fusing Cooling Fan Motor Failure**
- (18) **3047: PH Cooling Fan Motor Failure**
- (19) **3048: PU Cooling Fan Motor Failure**
- (20) **0040: Suction Fan Motor Failure**
- (21) **004C: Ozone Fan Motor Failure**
- (22) **004E: Power Supply Cooling Fan Motor Failure**

<Detection Timing>

Malfunction Code	Description
3046	When a locked signal is detected after the lapse of a predetermined period of time while the fan is rotating.
3047	
3048	
0040	
004C	
004E	

<Action>

Relevant Electrical Parts	
Fusing Cooling Fan Motor (M7) PH Cooling Fan Motor (M8) PU Cooling Fan Motor (M12) Suction Fan Motor (M13) Ozone Fan Motor (M9) Power Supply Cooling Fan Motor (M6)	Control Board (PWB-A)

* 3046

Step	Action	Ref. Page	WIRING DIAGRAM	
			Control Signal	(Location) (Electrical Parts)
1	Check the motor connector for proper connection and correct as necessary.	—	—	—
2	Check the fan for possible overload and correct as necessary.	—	—	—
3	M7 Operation Check	☞ T-3	PWB-A CNF1-A-10 (REM)	10-G
4	Change PWB-A.	—	—	—

* 3047

Step	Action	Ref. Page	WIRING DIAGRAM	
			Control Signal	(Location) (Electrical Parts)
1	Check the motor connector for proper connection and correct as necessary.	—	—	—
2	Check the fan for possible overload and correct as necessary.	—	—	—
3	M8 Operation Check	☞ T-3	PWB-A CNF2-A-1 (REM)	5-G
4	Change PWB-A.	—	—	—

* 3048

Step	Action	Ref. Page	WIRING DIAGRAM	
			Control Signal	(Location) (Electrical Parts)
1	Check the motor connector for proper connection and correct as necessary.	—	—	—
2	Check the fan for possible overload and correct as necessary.	—	—	—
3	M12 Operation Check	☞ T-3	PWB-A CNF1-A-10 (REM)	7-C
4	Change PWB-A.	—	—	—

* 004C

Step	Action	Ref. Page	WIRING DIAGRAM	
			Control Signal	(Location) (Electrical Parts)
1	Check the motor connector for proper connection and correct as necessary.	—	—	—
2	Check the fan for possible overload and correct as necessary.	—	—	—
3	M13 Operation Check	☞ T-3	PWB-A CNF1-A-10 (REM)	12-A
4	Change PWB-A.	—	—	—

* 004C

Step	Action	Ref. Page	WIRING DIAGRAM	
			Control Signal	(Location) (Electrical Parts)
1	Check the motor connector for proper connection and correct as necessary.	—	—	—
2	Check the fan for possible overload and correct as necessary.	—	—	—
3	M9 Operation Check	 T-3	PWB-A CNF4-A-1 (REM)	9-E
4	Change PWB-A.	—	—	—

* 004E

Step	Action	Ref. Page	WIRING DIAGRAM	
			Control Signal	(Location) (Electrical Parts)
1	Check the motor connector for proper connection and correct as necessary.	—	—	—
2	Check the fan for possible overload and correct as necessary.	—	—	—
3	M6 Operation Check	 T-3	PWB-A CNF3-A-1 (REM)	17-C
4	Change PWB-A.	—	—	—

(23) 0094: 2nd Image Transfer Roller Pressure/Retraction failure

(24) 0096: Image Transfer Belt Pressure/Retraction failure

<Detection Timing>

Malfunction Code	Description
0094	The 2nd Image Transfer Pressure/Retraction Sensor is not activated after the 2nd Image Transfer Roller retracts.
0096	The 1st Image Transfer Pressure/Retraction Sensor is not activated after the 1st Image Transfer Roller retracts.

<Action>

Relevant Electrical Parts	
1st Image Transfer Pressure Position Sensor (PC24) 2nd Image Transfer Pressure Position Sensor (PC25)	Control Board (PWB-A)

* 0094

Step	Action	Ref. Page	WIRING DIAGRAM	
			Control Signal	(Location) (Electrical Parts)
1	PC25 Operation Check	T-1	PWB-A CNF1-A-3 (ON)	3-G
2	Change PWB-A.	—	—	—

* 0096

Step	Action	Ref. Page	WIRING DIAGRAM	
			Control Signal	(Location) (Electrical Parts)
1	PC24 Operation Check	T-1	PWB-A CNIT-A-5 (ON)	3-G
2	Change PWB-A.	—	—	—

- (25) 0060: Fusing Drive Motor Failure
- (26) 3020: Paper Take-Up Drive Motor Failure
- (27) 3021: Transport Drive Motor Failure
- (28) 3022: Duplex Unit Drive Motor Failure
- (29) 3023: Manual Bypass Unit Paper Take-Up Motor Failure

<Detection Timing>

Malfunction Code	Description
0060	The Fire Check Detection Signal is detected as H while the motor is rotating.
3020	The Fire Check Detection signal is detected as H while the motor is rotating.
3021	The Fire Check Detection signal is detected as H while the motor is rotating.
3022	The Fire Check Detection signal is detected as L while the motor is rotating.
3023	The Fire Check Detection signal is detected as L while the motor is rotating.

<Action>

Relevant Electrical Parts	
Paper Take-Up Drive Motor (M1) Transport Drive Motor (M2) Duplex Unit Drive Motor (M10) Manual Bypass Paper Take-Up Motor (M11) Fusing Drive Motor (M3)	Manual Bypass Detecting Board (PWB-Y) Duplex Unit Control Board (PWB-X) Control Board (PWB-A)

* 0060

Step	Action	Ref. Page	WIRING DIAGRAM	
			Control Signal	(Location) (Electrical Parts)
1	Check the motor connector for proper connection and correct as necessary.	—	—	—
2	Check the motor for proper drive coupling and correct as necessary.	—	—	—
3	M5 Operation Check	 T-3	PWB-A CNPM-A-5B (ON)	12-H
4	Change PWB-A.	—	—	—

* 3020

Step	Action	Ref. Page	WIRING DIAGRAM	
			Control Signal	(Location) (Electrical Parts)
1	Check the motor connector for proper connection and correct as necessary.	—	—	—
2	Check the motor for proper drive coupling and correct as necessary.	—	—	—
3	M1 Operation check	T-3	PWB-A CNSTM-A-5 to 8 (Pulse Output)	14-B
4	Change PWB-A.	—	—	—

* 3021

Step	Action	Ref. Page	WIRING DIAGRAM	
			Control Signal	(Location) (Electrical Parts)
1	Check the motor connector for proper connection and correct as necessary.	—	—	—
2	Check the motor for proper drive coupling and correct as necessary.	—	—	—
3	M2 Operation check	T-3	PWB-A CNSTM-A-1 to 4 (Pulse Output)	12-A
4	Change PWB-A.	—	—	—

* 3022

Step	Action	Ref. Page	WIRING DIAGRAM	
			Control Signal	(Location) (Electrical Parts)
1	Check the motor connector for proper connection and correct as necessary.	—	—	—
2	Check the motor for proper drive coupling and correct as necessary.	—	—	—
3	M101 Operation check	T-3	PWB-X PJ2-X-1 to 4 (Pulse Output)	22-H
4	Change PWB-X.	—	—	—
5	Change PWB-A.	—	—	—

* 3023

Step	Action	Ref. Page	WIRING DIAGRAM	
			Control Signal	(Location) (Electrical Parts)
1	Check the motor connector for proper connection and correct as necessary.	—	—	—
2	Check the motor for proper drive coupling and correct as necessary.	—	—	—
3	M11 Operation check	T-3	PWB-Y PJ2-Y-1 to 4 (Pulse Output)	22-F
4	Change PWB-Y.	—	—	—
5	Change PWB-A.	—	—	—

(30) 0250: Power Supply (24 V) Failure

<Detection Timing>

Malfunction Code	Description
0250	When the Power supply alarm is continuously detected after the lapse of a predetermined period of time while the 24V remote is ON and the Hard Alarm is OFF.

<Action>

Relevant Electrical Parts	
Front Door Switch (S1) Front Door Open Close Detecting Switch (S2) Left Door Switch (S3) Right Door Open Close Detecting Sensor (PC27)	DC Power Supply (PU1) Control Board (PWB-A)

Step	Action	Ref. Page	WIRING DIAGRAM	
			Control Signal	(Location) (Electrical Parts)
1	PC27 Operation Check	T-1	PWB-A CNF1-A-9 (ON)	6-I
2	S1 Operation Check	T-2	PWB-A CNFCO-A-1 (ON)	17-B
3	S2 Operation Check	T-2	PWB-A CNPWC-A-1 (ON)	17-A
4	S3 Operation Check	T-2	PWB-A CNPWC-A-1 (ON)	17-A
5	Change PWB-T.	—	—	—
6	Change PWB-A.	—	—	—
7	Change PU1.	—	—	—

(31) 0300: Polygon Motor Failure

<Detection Timing>

Malfunction Code	Description
0300	<ul style="list-style-type: none"> After the Polygon Motor is started, the Spindle Alarm Signal (SPALM) is not cancelled even after a predetermined period of time has lapsed. The Spindle Alarm Signal is detected for longer than a predetermined period of time during regular rotation of the Polygon Motor.

<Action>

Relevant Electrical Parts	
PH Unit Flat Cable (CNVD)	Control Board (PWB-A)

Step	Action	Ref. Page	WIRING DIAGRAM	
			Control Signal	(Location) (Electrical Parts)
1	Check the cable for proper connection and correct as necessary.	—	—	—
2	Change the PH unit.	—	—	—
3	Change PWB-A.	—	—	—

(32) 0310: Laser Failure

<Detection Timing>

Malfunction Code	Description
0310	When L is detected while the ready signal is activated for longer than a predetermined period of time while laser is being emitted.

<Action>

Relevant Electrical Parts	
PH Unit Flat Cable (CNVD)	Control Board (PWB-A)

Step	Action	Ref. Page	WIRING DIAGRAM	
			Control Signal	(Location) (Electrical Parts)
1	Check the cable for proper connection and correct as necessary.	—	—	—
2	Change the PH Unit.	—	—	—
3	Change PWB-A.	—	—	—

- (33) 0500: Heating Roller Warm-Up Failure**
- (34) 0501: Fusing Pressure Warm-Up Failure**
- (35) 0510: Heating Roller abnormally low temperature**
- (36) 0511: Fusing Pressure Roller abnormally low temperature**
- (37) 0520: Heating Roller abnormally high temperature**
- (38) 0521: Fusing Pressure Roller abnormally high temperature**

<Detection Timing>

Malfunction Code	Description
0500	The Heating Roller Thermistor does not detect a predetermined temperature after the lapse of a predetermined period of time after a warm-up cycle has been started and thus the printer does not complete the warm-up cycle.
0501	The Fusing Pressure Roller Thermistor does not detect a predetermined temperature after the lapse of a predetermined period of time after a warm-up cycle has been started and thus the printer does not complete the warm-up cycle.
0510	When the predetermined temperature of the Heating Roller Thermistor decreases for more than a predetermined period of time.
0511	When the predetermined temperature of the Fusing Pressure Roller Thermistor decreases for more than a predetermined period of time.
0520	When the predetermined temperature of the Heating Roller Thermistor increases for more than a predetermined period of time.
0521	When the predetermined temperature of the Fusing Pressure Roller Thermistor increases for more than a predetermined period of time.

<Action>

Relevant Electrical Parts	
Fuser Unit	Heater Lamp Control Board (PWB-T) DC Power Supply (PU1) Control Board (PWB-A)

* 0500, 0501, 0510, 0511, 0520, 0521

Step	Action	Ref. Page	WIRING DIAGRAM	
			Control Signal	(Location) (Electrical Parts)
1	Replacing the Fuser Unit	—	—	—
2	Change PWB-T.	—	—	—
3	Change PWB-A.	—	—	—
4	Change PU1.	—	—	—

(39) FFFF: I/F Communication Failure

<Detection Timing>

Malfunction Code	Description
FFFF	Engine I/F Communication Failure Detected

<Action>

Relevant Electrical Parts	
Flat Cable (CNLC)	Control Board (PWB-A) Controller Board (PWB-Z)

Step	Action	Ref. Page	WIRING DIAGRAM	
			Control Signal	(Location) (Electrical Parts)
1	Check the cable for proper connection and correct or change as necessary.	—	—	—
2	Change PWB-A.	—	—	—
3	Change PWB-Z.	—	—	—

4. POWER SUPPLY-RELATED MALFUNCTIONS

4-1. Printer is not energized at all

Relevant Electrical Parts	
Control Board (PWB-A)	DC Power Supply 1 (PU1)

Step	Check Item	WIRING DIAGRAM (Location)	Result	Action
1	Is power voltage supplied across PJ3PU1-1 and 3 on PU1?	16-A	NO	Check wiring between the wall outlet and PJ3PU1.
2	Are the fuses (F1 and F2) on PU1 conducting?	—	NO	Change PU1.
4	Has DC5 V and DC24 V been input into the CNPOW-A on the Control Board?	16-H	NO	Change PU1.
			YES	Change PWB-A.

5. OTHER PRECAUTIONS

5-1. Emergency Stop Error

(1) Door Open Error

Message	Detection Timing	Error Release Conditions
COVER OPEN CHECK SIDE DOOR	The Right Door Open Signal is continuously detected for more than a predetermined period of time.	Close the Right Door.
COVER OPEN CHECK FRONT DOOR	The Front Door Open signal is continuously detected for more than a predetermined period of time.	Close the Front Door.
COVER OPEN CHECK DUP. DOOR	The Duplex Cover Open signal is continuously detected for more than a predetermined period of time.	Close the Duplex Cover.
COVER OPEN CHECK TRAY2 DOOR	The 2nd Drawer Side cover Open Signal is continuously detected for more than a predetermined period of time.	Close the 2nd Drawer Side Cover.
COVER OPEN CHECK TRAY3 DOOR	When the 3rd Drawer Side Cover Open signal is continuously detected for more than a predetermined period of time 3	Close the 3rd Drawer Side Cover.
COVER OPEN CHECK TRAY4 DOOR	When the 4th Drawer Side Cover Open signal is continuously detected for more than a predetermined period of time.	Close the 4th Drawer Side Cover.

(2) Unit not mounted error

Message	Detection Timing	Error Release Conditions
TONER MISSING CHECK x	When the system detects toner cartridge x has not been installed after the Power supply is turned ON and the cover is opened and closed.	After installing toner cartridge x, close the front door, and turn the power ON again.
FUSING MISSING CHECK UNIT	When the system detects no Fuser Unit mounted after the Power supply is turned ON and the cover is opened and closed.	After mounting the Fuser Unit, close the right door and turn the Power Supply ON.
P-UNIT MISSING CHECK x	When the system detects printer unit x not installed after the Power supply is turned ON and the cover is opened and closed.	After installing printer unit x, close the front door, and turn the power ON again.

5-2. Print Prohibition Error

Message	Detection Timing	Error Release Conditions
WASTE TONER FULL REPLACE BOX	When the waste toner bottle is full of waste toner.	After replacing the waste toner bottle, close the front door or turn the Power Supply ON.
MEDIA SIZE ERROR TRAY x	When the paper size designated by the printer driver differs from the size of the paper fed.	Set the paper size indicated by the printer driver into the tray.
MEDIA SIZE ERR ADD yy		
TRAY x SIZE ERR ADD yy		
TRAY x TYPE ERR ADD yy	When the paper type designated by the printer driver differs from the paper type fed.	Set the paper type indicated by the printer driver into the tray.
MANL TYPE ERR ADD xx		
OUTPUT FULL REMOVE MEDIA	The Exit Tray is at Full Capacity.	Remove paper from the Exit Tray.

5-3. Warning Error

Message	Detection Timing	Error Release Conditions
WASTE NEAR FULL	The Waste Toner Bottle is detected as being nearly-full.	Replace the Waste Toner Bottle, and OPEN/CLOSE Front Door or turn the Power Switch to ON again.
TONER LOW x	When the toner (x) is detected as being nearly empty.	After replacing the toner cartridge, OPEN/CLOSE the front door or turn the Power ON again.
P-UNIT LOW x	When the printer unit (x) is detected as being near its operational lifetime.	After replacing the printer unit x, OPEN/CLOSE the front door or turn the Power ON again.
FUSER LOW	When the Fuser unit is detected as being near its operational life.	After replacing the Fuser unit, OPEN/CLOSE the front door or turn the Power Switch ON again.
TRANS. BELT LOW	When the Image Transfer unit is detected as being near its operational life.	After replacing the Image Transfer unit, OPEN/CLOSE the front door or turn the Power Switch ON again.

6. IMAGE PROBLEM

6-1. Troubleshooting Procedure by a Particular Image Quality Problem

- (1) IR System: white lines in FD, white bands in FD, colored lines in FD, and colored bands in FD

<Typical Faulty Images>

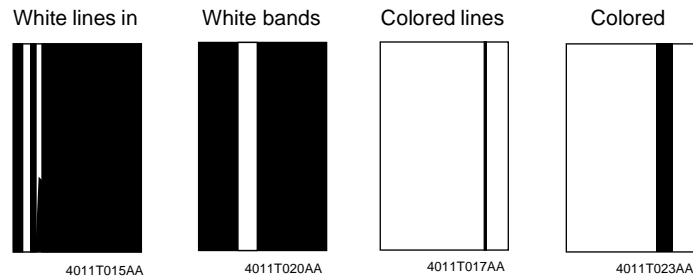

<Troubleshooting Procedure>

Section	Step	Check Item	Result	Action
PU	1	The surface of the PC Drum is scratched.	YES	Change PU.
	2	Dirty on the outside.	YES	Clean.
	3	Connectors and contact terminals make good connection between each color PU and PH Unit.	NO	Clean contact terminals. Reconnect.
	4	Developing bias contact terminal makes good connection.	NO	Clean contact terminal and check terminal position.
PH Unit	5	The surface of the window is dirty.	YES	Clean. ☞ D-32DISASSEMBLY/REASSEMBLY
Transfer Belt Unit	6	Fingerprints, oil, or other foreign matter is evident on the Image Transfer Belt.	YES	Clean with specified solvent. ☞ D-31DISASSEMBLY/REASSEMBLY
	7	Image Transfer Belt is dirty or scratched.	YES	Clean dirty belt with a soft cloth. Change Transfer Belt Unit if belt is damaged.
	8	Image Transfer Roller is dirty or scratched.	YES	Change the Transfer Belt Unit.
Paper path	9	There is foreign matter on paper path.	YES	Remove foreign matter.

Fuser Unit	10	Fusing Entrance Guide Plate is dirty or damaged.	YES	Clean. Replacing the Fuser Unit.
	11	Fusing Paper Separator Fingers are dirty.	YES	Replacing the Fuser Unit.
	12	The problem has been eliminated by checking up to Step 11.	NO	Change PU Replacing the Transfer Belt Unit. Replacing PH unit. Replacing the Fuser Unit.



(2) white lines in CD, white bands in CD, colored lines in CD, and colored bands in CD

<Typical Faulty Images>

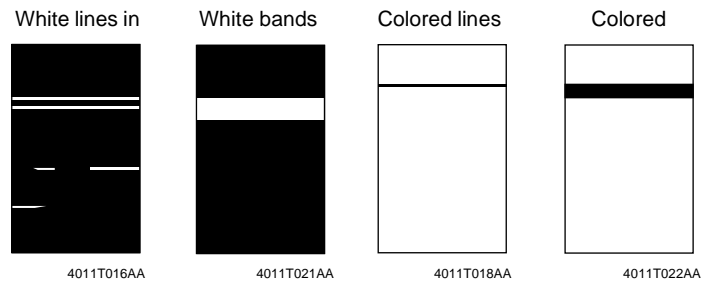

<Troubleshooting Procedure>

Section	Step	Check Item	Result	Action
PU	1	The surface of the PC Drum is scratched.	YES	Change PU.
	2	Dirty on the outside.	YES	Clean.
	3	Connectors and contact terminals make good connection between each PU and PH Unit.	NO	Clean contact terminals. Reconnect.
	4	Developing bias contact terminal makes good connection.	NO	Clean contact terminal and check terminal position.
Transfer Belt Unit	5	Image Transfer Belt is dirty or scratched.	YES	Clean dirty belt with a soft cloth. Change Transfer Belt Unit if belt is damaged.
	6	2nd Image Transfer Roller is dirty or scratched.	YES	Replacing the Transfer Belt Unit.
Paper path	7	There is foreign matter on paper path.	YES	Remove foreign matter.
Fuser Unit	8	Fusing Entrance Guide Plate is dirty or damaged.	YES	Clean. ⇒ D-31DISASSEMBLY/REASSEMBLY Replacing the Fuser Unit.
	9	Fusing Paper Separator Fingers are dirty.	YES	Replacing the Fuser Unit.
	10	The problem has been eliminated by checking up to Step 9.	NO	Change the PU. Replacing the Transfer Belt Unit. Replacing the Fuser Unit.

(3) Uneven FD Density

<Typical Faulty Images>



4011T031AA



4011T042AA



4004T011AA



<Troubleshooting Procedure>

Section	Step	Check Item	Result	Action
PU	1	The surface of the PC Drum is scratched.	YES	Change the PU.
	2	Dirty on the outside.	YES	Clean.
PH Unit	3	The surface of the window is dirty.	YES	Clean. ⇒ D-32DISASSEMBLY/REASSEMBLY
Transfer Belt Unit	4	Image Transfer Belt is dirty or scratched.	YES	Clean dirty belt with a soft cloth. Change Transfer Belt Unit if belt is damaged.
	5	Terminal is dirty.	YES	Clean.
	6	2nd Image Transfer Roller is dirty or scratched.	YES	Replacing the Transfer Belt Unit.
	7	The problem has been eliminated by checking up to Step 7.	NO	Change the PU. Cooling of PH unit. → Replacing the High Pressure Unit 1. → Replacing the High Pressure Unit 2.

(4) Uneven CD Density

<Typical Faulty Images>



4011T032AA



4011T043AA

<Troubleshooting Procedure>

Section	Step	Check Item	Result	Action
PU	1	The surface of the PC Drum is scratched.	YES	Change the PU.
	2	Dirty on the outside.	YES	Clean.
Transfer Belt Unit	3	Transfer Belt Unit makes positive contact with plates on rails.	NO	Check and correct contacts.
	4	Fingerprints, oil, or other foreign matter is evident on the Image Transfer Belt.	YES	Clean with specified solvent. ⇒ D-31DISASSEMBLY/REASSEMBLY
	5	Image Transfer Belt is dirty or scratched.	YES	Clean dirty belt with a soft cloth. Change Transfer Belt Unit if belt is damaged.
	6	Terminal is dirty.	YES	Clean.
	7	Image Transfer Roller is dirty or scratched.	YES	Replacing the Transfer Belt Unit.
	8	The problem has been eliminated by checking up to Step 8.	NO	Change the PU. → Replacing the High Pressure Unit 1. → Replacing the High Pressure Unit 2.

(5) Low Density (lowered ID)

<Typical Faulty Images>



4011T003AA



<Troubleshooting Procedure>

Section	Step	Check Item	Result	Action
PU	1	Dirty on the outside.	YES	Clean.
PH Unit	2	The surface of the window is dirty.	YES	Clean. ⇒ D-32DISASSEMBLY/REASSEMBLY
Transfer Belt Unit	3	Transfer Belt Unit makes positive contact with plates on rails.	NO	Check and correct contacts.
	4	Terminal is dirty.	YES	Clean.
Paper	5	Paper is damp.	YES	Change paper to one just unwrapped from its package.
AIDC Sensor	6	Sensor is dirty.	YES	Clean. ⇒ D-32DISASSEMBLY/REASSEMBLY
	7	The problem has been eliminated through the checks of steps up to 7.	NO	Change the PU. Replacing the Transfer Belt Unit. Replacing the PH unit. → Replace AIDC sensor. → Replace the PWB-Aboard. → Replacing High Pressure Unit 1. → Replacing High Pressure Unit 2.

(6) Gradation Failure

<Typical Faulty Images>

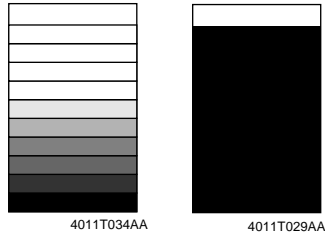

<Troubleshooting Procedure>

Section	Step	Check Item	Result	Action
PU	1	Dirty on the outside.	YES	Clean.
PH Unit	2	The surface of the window is dirty.	YES	Clean. ⇒ D-32DISASSEMBLY/REASSEMBLY
AIDC Sensor	3	Sensor is dirty.	YES	Clean. ⇒ D-32DISASSEMBLY/REASSEMBLY
	4	The problem has been eliminated by checking up to Step 3.	NO	Change the PU. Cooling of PH unit. → Replacing the AIDC sensor. → Replacing the High Pressure Unit 1. → Replacing the High Pressure Unit 2.

(7) Color Reproduction Failure

<Typical Faulty Images>



4011T050AA



<Troubleshooting Procedure>

Section	Step	Check Item	Result	Action
Paper	1	Paper is damp.	YES	Change paper to one just unwrapped from its package. Install Paper Dehumidifying Heater.
Transfer Belt Unit	2	Terminal is dirty.	YES	Clean.
AIDC Sensor	3	Sensor is dirty.	YES	Clean. ⇒ D-32DISASSEMBLY/REASSEMBLY
	4	The problem has been eliminated by checking up to Step 4.	NO	Replacing the Transfer Belt Unit. → Replace the AIDC sensor. → Replace the PWB-Aboard. → Replacing High Pressure Unit 1. → Replacing High Pressure Unit 2.

(8) Foggy Background

<Typical Faulty Images>

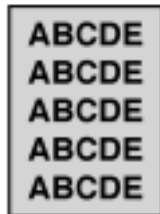

4011T004AA

<Troubleshooting Procedure>

Section	Step	Check Item	Result	Action
PU	1	The surface of the PC Drum is scratched.	YES	Change the PU.
	2	Dirty on the outside.	YES	Clean.
	3	Connectors and contact terminals make good connection between each PU and PH Unit.	NO	Clean contact terminals. Reconnect.
	4	Developing bias contact terminal makes good connection.	NO	Clean contact terminal and check terminal position.
PH Unit	5	The surface of the window is dirty.	YES	Clean. ⇒ D-32DISASSEMBLY/REASSEMBLY
AIDC Sensor	6	Sensor is dirty.	YES	Clean. ⇒ D-32DISASSEMBLY/REASSEMBLY
	7	The problem has been eliminated by checking up to Step 6.	NO	Change the PU. → Change the PH Unit. → Replacing the AIDC sensor.

(9) Void area, white spots

<Typical Faulty Images>

Void areas

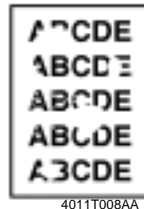

4011T008AA

White spots

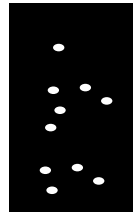

4011T030AA



<Troubleshooting Procedure>

Section	Step	Check Item	Result	Action
PU	1	The surface of the PC Drum is scratched.	YES	Change the PU.
	2	Dirty on the outside.	YES	Clean.
Transfer Belt Unit	3	Fingerprints, oil, or other foreign matter is evident on the Transfer Belt.	YES	Clean with specified solvent. ⇒ D-31 DISASSEMBLY/REASSEMBLY
	4	Image Transfer Belt is dirty or scratched.	YES	Clean dirty belt with a soft cloth. Change Transfer Belt Unit if belt is damaged.
	5	Image Transfer Roller is dirty or scratched.	YES	Replace the Transfer Belt Unit.
	6	Charge Neutralizing Cloth is not separated and ground terminal is connected properly.	NO	Correct or change.
Paper path	7	There is foreign matter on paper path.	YES	Remove foreign matter.
	8	Pre-Image Transfer Guide Plate is damaged or dirty.	YES	Clean or change.
	9	The problem has been eliminated by checking up to Step 8.	NO	Change the PU. → Replace the Transfer Belt Unit.

(10) Faulty Image

<Typical Faulty Images>

Typical Faulty

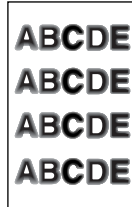

4011T046AA

<Troubleshooting Procedure>

Section	Step	Check Item	Result	Action
PH Unit	1	The surface of the Window is dirty.	YES	Clean. ⇒ D-32DISASSEMBLY/REASSEMBLY
PU	2	Dirty on the outside.	YES	Clean.
	3	The problem has been eliminated by checking up to Step 2.	NO	Change the PU. → Cooling of PH unit.

(11) Blank Copy, Black Copy

<Typical Faulty Images>

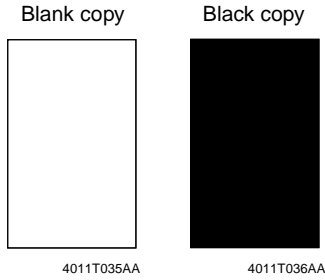

<Troubleshooting Procedure>

Section	Step	Check Item	Result	Action
Image Check	1	A blank copy occurs.	YES	Check PH Unit connector for proper connection.
PU	2	Coupling of PU drive mechanism is installed properly.	NO	Check and correct the Drive Transmitting Coupling or replace the PU.
	3	The PC Drum Charge Corona voltage contact or PC Drum ground contact of the Imaging Unit is connected properly.	NO	Check, clean, or correct the contact.
High Pressure Unit 1/High Pressure Unit 2	4	Connector is connected properly.	NO	Reinstall.
	5	The problem has been eliminated through the check of step 4.	NO	Replace High Pressure Unit 1. → Replace High Pressure Unit 2. → Replace PWB-A board. → Replacing the PH unit.

(12) Color Shift Failure

<Typical Faulty Images>

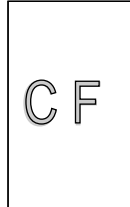

4011T049AA

<Troubleshooting Procedure>

Section	Step	Check Item	Result	Action
Transfer Belt Unit	1	Fingerprints, oil, or other foreign matter is evident on the Transfer Belt.	YES	Clean with specified solvent. ⇒ D-31DISASSEMBLY/REASSEMBLY
	2	Image Transfer Belt is dirty or scratched.	YES	Clean dirty belt with a soft cloth. Change Transfer Belt Unit if belt is damaged.
	3	Drive coupling to the printer is dirty.	YES	Clean.
	4	Image Transfer Roller is dirty or scratched.	YES	Replace Transfer Belt Unit.
PU	5	PU is connected properly.	NO	Reset the PU.
	6	The surface of the PC Drum is scratched.	YES	Change the PU.
	7	The problem has been eliminated by checking up to Step 7.	NO	Replace the Transfer Belt Unit. → Replace the PH Unit. → Replace the PWB-A board.

(13) Colored Spots

<Typical Faulty Images>

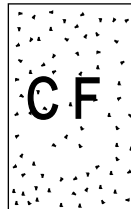

4011T027AA

<Troubleshooting Procedure>

Section	Step	Check Item	Result	Action
PU	1	Are the colored spots mono color?	YES	Replace the PU.
	2	The surface of the PC Drum is scratched.	YES	Replace the PU.
Transfer Belt Unit	3	Fingerprints, oil, or other foreign matter is evident on the Transfer Belt.	YES	Clean with specified solvent. ☞ D-31DISASSEMBLY/REASSEMBLY
	4	Image Transfer Belt is dirty or scratched.	YES	Clean dirty belt with a soft cloth. Change Transfer Belt Unit if belt is damaged.
	5	Image Transfer Roller is dirty or scratched.	YES	Replace the Transfer Belt Unit.
Paper path	6	There is foreign matter on paper path.	YES	Remove foreign matter.
Fuser Unit	7	Image Transfer Roller is dirty or scratched.	YES	Replacing the Fuser Unit.
	8	The problem has been eliminated by checking up to Step 7.	NO	Replace the PU. → Replace the Transfer Belt Unit. → Replacing the Fuser Unit.

(14) Poor Fusing Performance, Offset

<Typical Faulty Images>

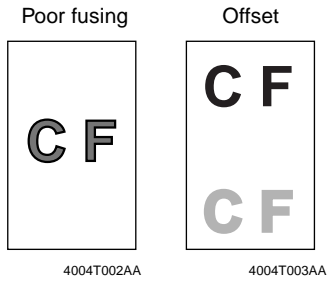

<Troubleshooting Procedure>

Section	Step	Check Item	Result	Action
Paper	1	Does paper meet product specifications?	NO	Change paper.
	2	The problem has been eliminated by checking up to Step 1.	NO	Replacing the Fuser Unit. → Replace the PWB-T board. → Change PWB-A.

(15) Brush Effect, Blurred Image

<Typical Faulty Images>

Brush effect



4004T004AA

Blurred image

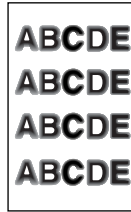

4011T046AA

<Troubleshooting Procedure>

Section	Step	Check Item	Result	Action
Paper	1	Paper is damp.	YES	Change paper to one just unwrapped from its package.
	2	Does paper meet product specifications?	NO	Replace the paper.
Fuser Unit	3	Fusing Entrance Guide Plate is dirty.	YES	Clean. ☞ D-31DISASSEMBLY/REASSEMBLY
			NO	Replacing the Fuser Unit.

(16) Back Marking

<Typical Faulty Images>

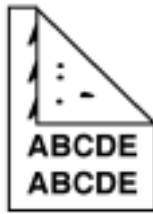

4011T009AA



4011T051AA

<Troubleshooting Procedure>

Section	Step	Check Item	Result	Action
Paper path	1	There is foreign matter on paper path.	YES	Remove foreign matter.
Fuser Unit	2	Fusing Entrance Guide Plate is scratched or dirty.	YES	Clean or change.
	3	Image Transfer Roller is scratched or dirty.	YES	Replacing the Fuser Unit.
Transfer Belt Unit	4	Fingerprints, oil, or other foreign matter is evident on the Transfer Belt.	YES	Clean with specified solvent. ⇒ D-31DISASSEMBLY/REASSEMBLY
	5	2nd Image Transfer Roller is dirty or scratched.	YES	Replace the Transfer Belt Unit.
	6	The problem has been eliminated by checking up to Step 5.	NO	Replace the Transfer Belt Unit. → Replacing the Fuser Unit. → Replacing High Pressure Unit 1. → Replacing High Pressure Unit 2.

(17) Uneven Pitch

<Typical Faulty Images>

38 mm Uneven Pitch

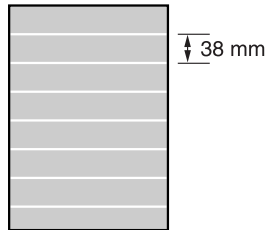

C4134S042AA

61 mm Uneven Pitch

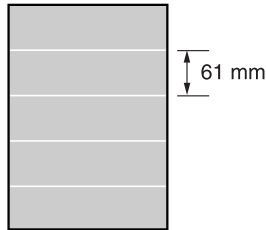

4134T006AA

76 mm Uneven Pitch

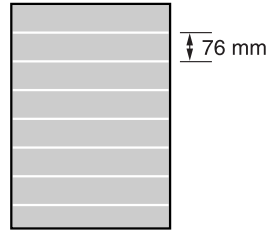

C4134S041AA

<Troubleshooting Procedure>

Section	Step	Check Item	Result	Action
Image Check	1	Periodic Occurrence of Uneven Pitch	NO	To Procedure 5
	2	38 mm pitch.	YES	Replace the PU
	3	76 mm pitch.	YES	Replace the PU and the Transfer Belt Unit.
	4	61 mm pitch.	YES	Replace the Transfer Belt Unit.
	5	98 mm pitch or 118 mm pitch.		Replacing the Fuser Unit.
	6	The problem has been eliminated by checking up to Step 5.	NO	Replace the PU. → Replace the Transfer Belt Unit. → Replacing the Fuser Unit. → Replace the PH Unit.

WIRING DIAGRAM

1/3

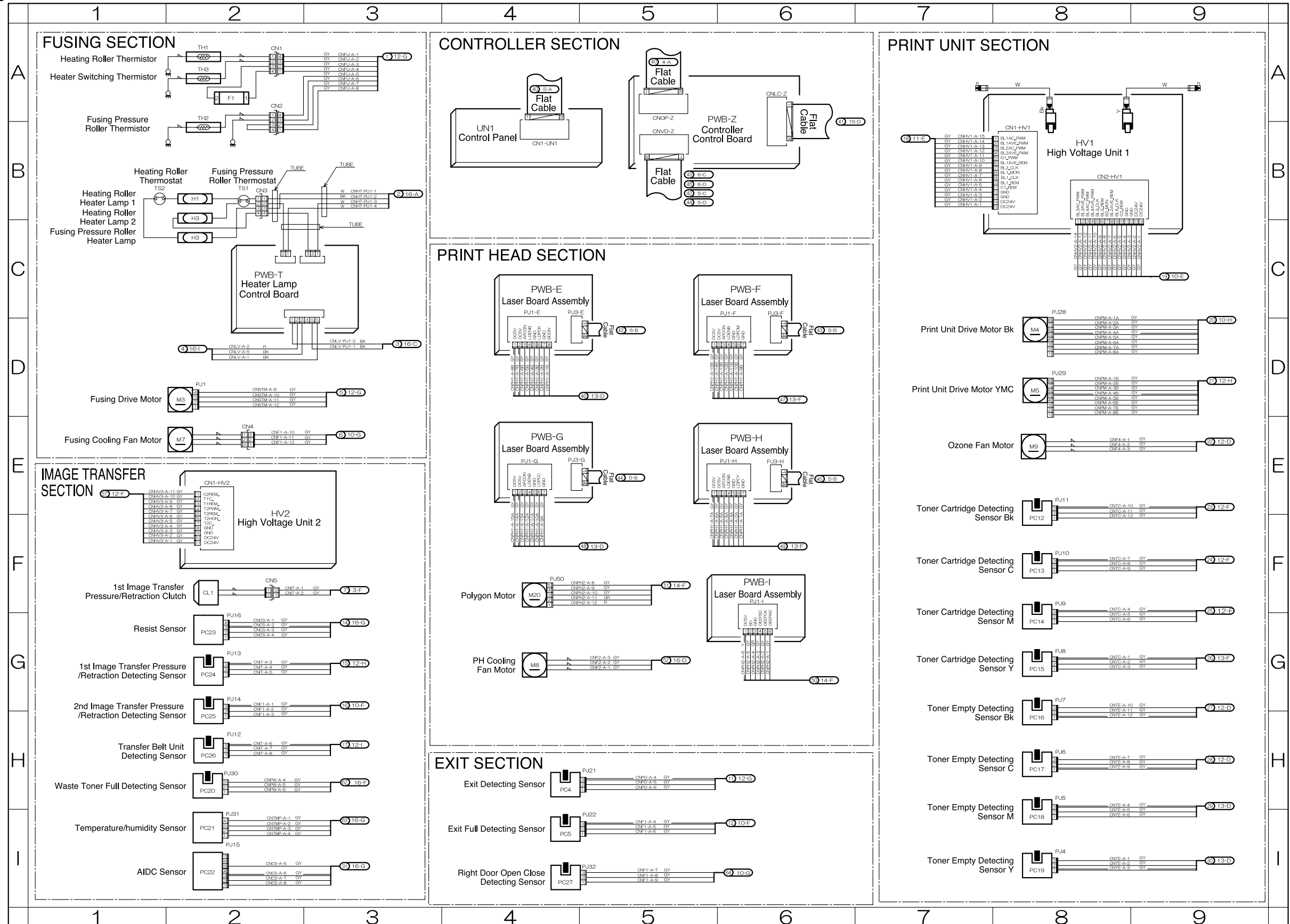

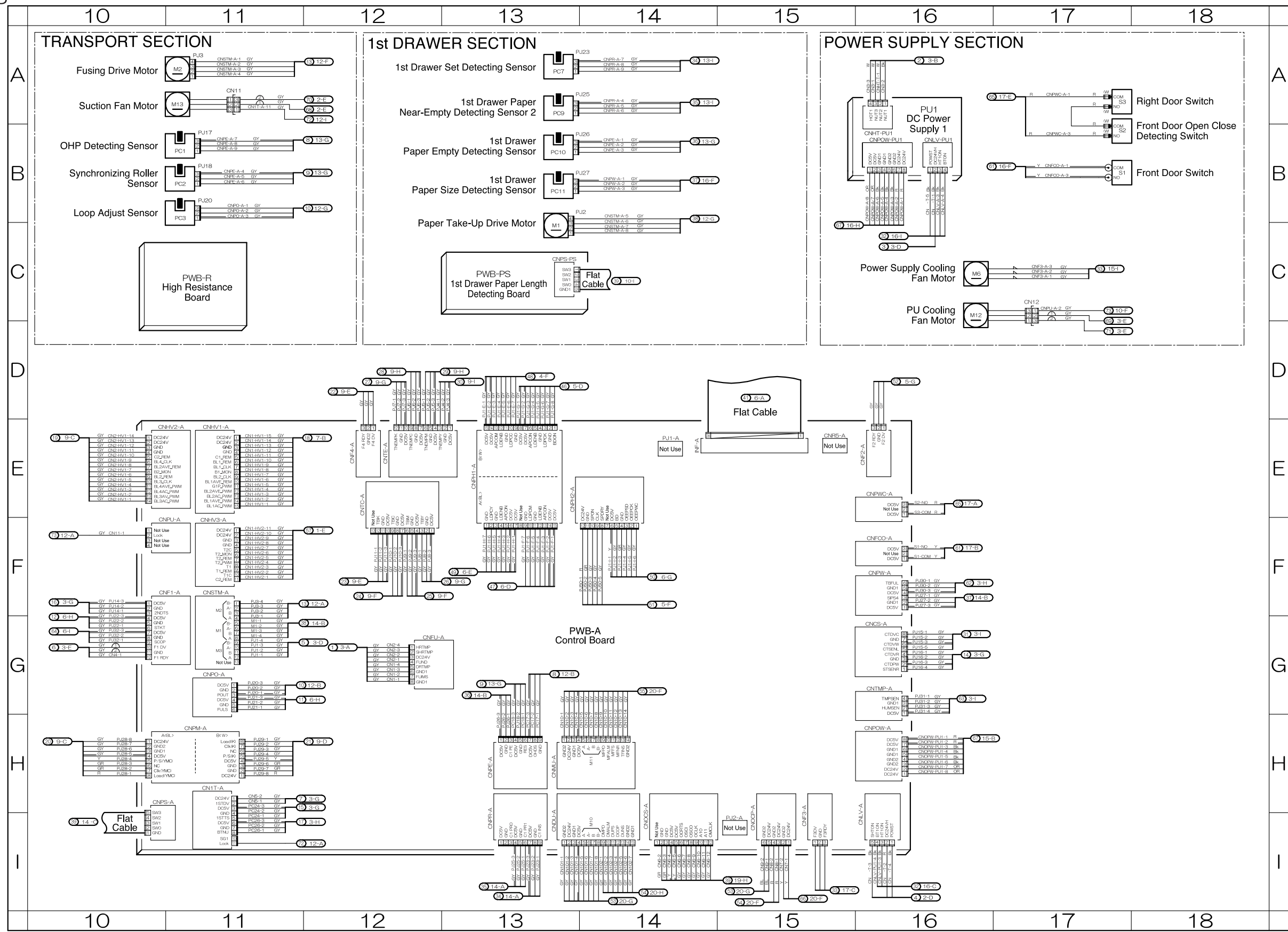

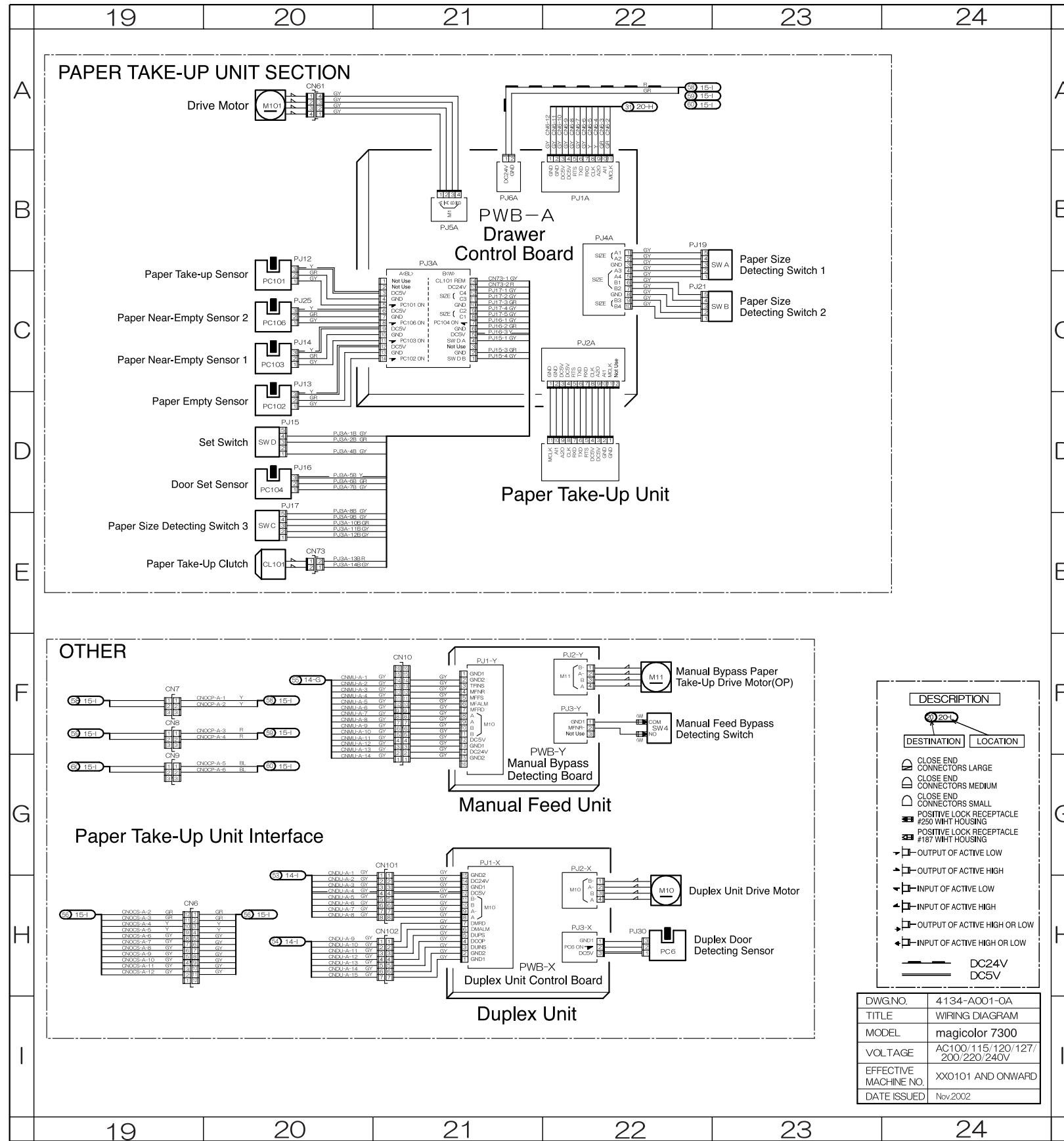

BASIC CIRCUIT DIAGRAM

1 / 2

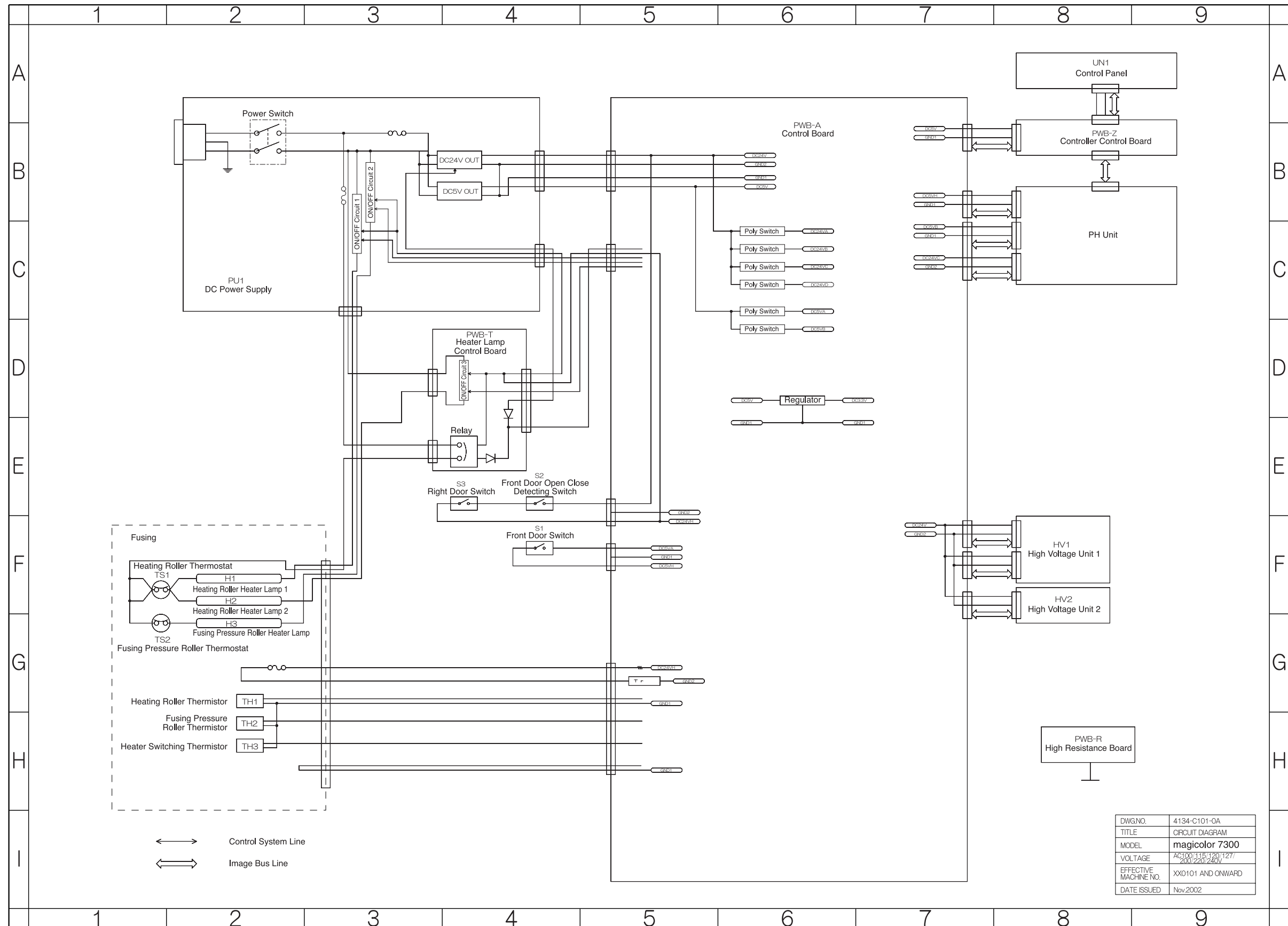

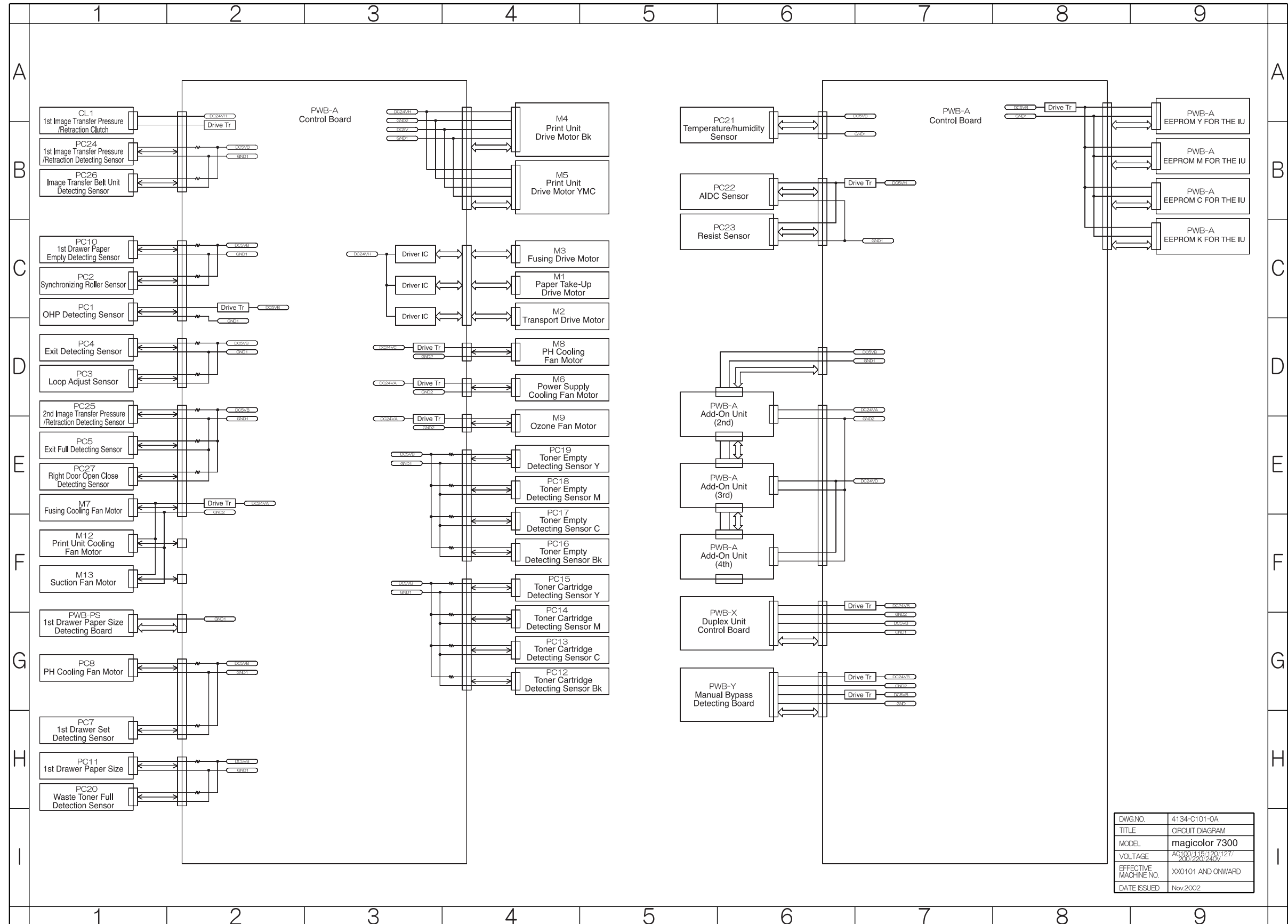

DWGNO.	4134-C101-0A
TITLE	CIRCUIT DIAGRAM
MODEL	magicolor 7300
VOLTAGE	AC100, 115, 120, 127, 200, 220, 240V
EFFECTIVE MACHINE NO.	XX0101 AND ONWARD
DATE ISSUED	Nov.2002